

Preliminary Version

Subject to changes



See the possibilities

*Digital Monochrome / Color
Compact Mini-CL Camera*

***CM-140MCL
CB-140MCL***

User's Manual

Document Version: Prelim.

Camera Revision: 0

CM-140 MCL / CB-140 MCL

1.	General.....	3
2.	Camera nomenclature	3
3.	Main Features	3
4.	Locations and Functions	4
5.	Pin Assignment.....	5
5.1.	12-pin Multi-connector (DC-IN/Trigger).....	5
5.2.	Digital Output Connector for Mini-CL (Camera Link).....	5
5.3.	Input and output circuits	6
5.3.1.	Iris video output	6
5.3.2.	Trigger input	6
5.3.3.	XEEN output	6
5.3.4.	Camera Link interface	6
6.	Functions and Operations	7
6.1.	Basic functions	7
6.1.1.	Digital Video Output (Bit Allocation).....	7
6.1.2.	Electronic Shutter	7
6.1.3.	Continuous operation or triggered operation	8
6.1.4.	Iris video output.	8
6.1.5.	Rear panel indicator.	8
6.1.6.	Auto-detect LVAL-sync / a-sync. accumulation	8
6.1.7.	Starting pixel - Bayer color mosaic	9
6.1.8.	Vertical Binning	9
6.2.	Sensor Layout and timing.....	10
6.2.1.	CCD Sensor Layout	10
6.2.2.	Horizontal timing.....	11
6.2.3.	Vertical timing.....	11
6.2.4.	Partial Scan.....	12
	Vertical Timing	12
	Horizontal Timing	13
6.2.5.	Vertical Binning.....	13
	Horizontal Timing.....	13
	Vertical timing	14
6.3.	Operation Modes	14
6.3.1.	Continuous operation	14
6.3.2.	Pre-select Trigger Mode	14
	LVAL_sync timing.....	15
	LVAL_a-sync timing	15
6.3.3.	Pulse Width Control Trigger Mode	16
	LVAL_sync timing.....	16
	LVAL_a-sync timing	17
6.4.	Mode and function matrix.	17
7.	Configuring the Camera	18
7.1.	RS-232C control	18
7.2.	Setting functions.....	19
7.2.1.	Bit allocation. BA=0, BA=1	19
7.2.2.	Partial scan. SC=0 through 4.....	19
7.2.3.	Vertical binning Binning. VB=0, VB=1	19
7.2.4.	Shutter mode. SM=0 and SM=1	19
7.2.5.	Trigger input select. TI=0, TI=1.	19
7.2.6.	Trigger polarity. TP=0, TP=1.	19
7.2.7.	Gain level. GA=-84 through +336.	19
7.2.8.	Black level. BL=0 through BL=1023.	19

CM-140 MCL / CB-140 MCL

7.3.	Save and Load Functions.....	19
7.4.	CM-140MCL / CB-140MCL command list	20
8.	Camera Control Tool for CM-140 MCL / CB-140 MCL.....	22
8.1.	Camera Control Tool Interface	22
8.1.1.	Camera Control Tool Bar	22
8.2.	The About Window.....	22
8.3.	Communication Window	23
8.4.	Camera Control Window	24
8.5.	Using the Camera Control Tool	24
9.	External Appearance and Dimensions	26
10.	Specifications	27
10.1.	10.1. Spectral sensitivity	27
10.2.	10.2. Specification table	28
11.	Appendix	29
10.3.	10.3. Precautions	29
10.4.	10.4. Typical Sensor Characteristics.....	29
10.5.	10.5. References.....	30
11.	User's Record	31

1. General

CM-140MCL is a monochrome progressive scan CCD camera and the CB-140MCL is the equivalent Bayer mosaic progressive scan CCD camera. Both have 1.45 M pixels resolutions. These cameras are suitable for a wide range of applications within factory automation, and also for applications outside the factory floor, such as ITS (Intelligent Traffic Solutions), high-end surveillance and medical.

The latest version of this manual can be downloaded from: www.jai.com

The latest version of Camera Control Tool for CM-140MCL/CB-140MCL can be downloaded from: www.jai.com

For camera revision history, please contact your local JAI distributor.

2. Camera nomenclature

The standard camera composition consists of the camera main body and C-mount protection cap.

The camera is available in the following versions:

CM-140 MCL

Where C stands for "Compact" family, M stands for "Monochrome", 140 represents the resolution "1.4 million pixel" and MCL stands for "Mini-CL" interface

CB-140 MCL

Where C stands for "Compact" family, B stands for "Bayer mosaic color", 140 represents the resolution "1.4 million pixel" and MCL stands for "Mini-CL" interface

3. Main Features

- Compact series 1/2" progressive scan camera
- Monochrome and Bayer mosaic color versions
- 1380 (h) x 1040 (v) active pixels
- 4.65 μm square pixels
- 31 frames/second with full resolution in continuous operation
- 30 frames/second with external trigger and full resolution
- Up to 74 frames/second with partial scan
- 48 frames/second with vertical binning (CM-140 MCL only)
- Shutter speed from 32 μs to 2 sec. using Pulse Width Control
- Programmable exposure from 64 μs to 40 ms
- Pre-select and Pulse width trigger modes
- LVAL-synchronous/-asynchronous operation (auto-detect)
- Vertical binning for higher sensitivity and higher frame rate
- Auto iris lens video output allows a wider range of light
- 10 or 8-bit output
- Setup by Windows NT/2000/XP via serial communication

4. Locations and Functions

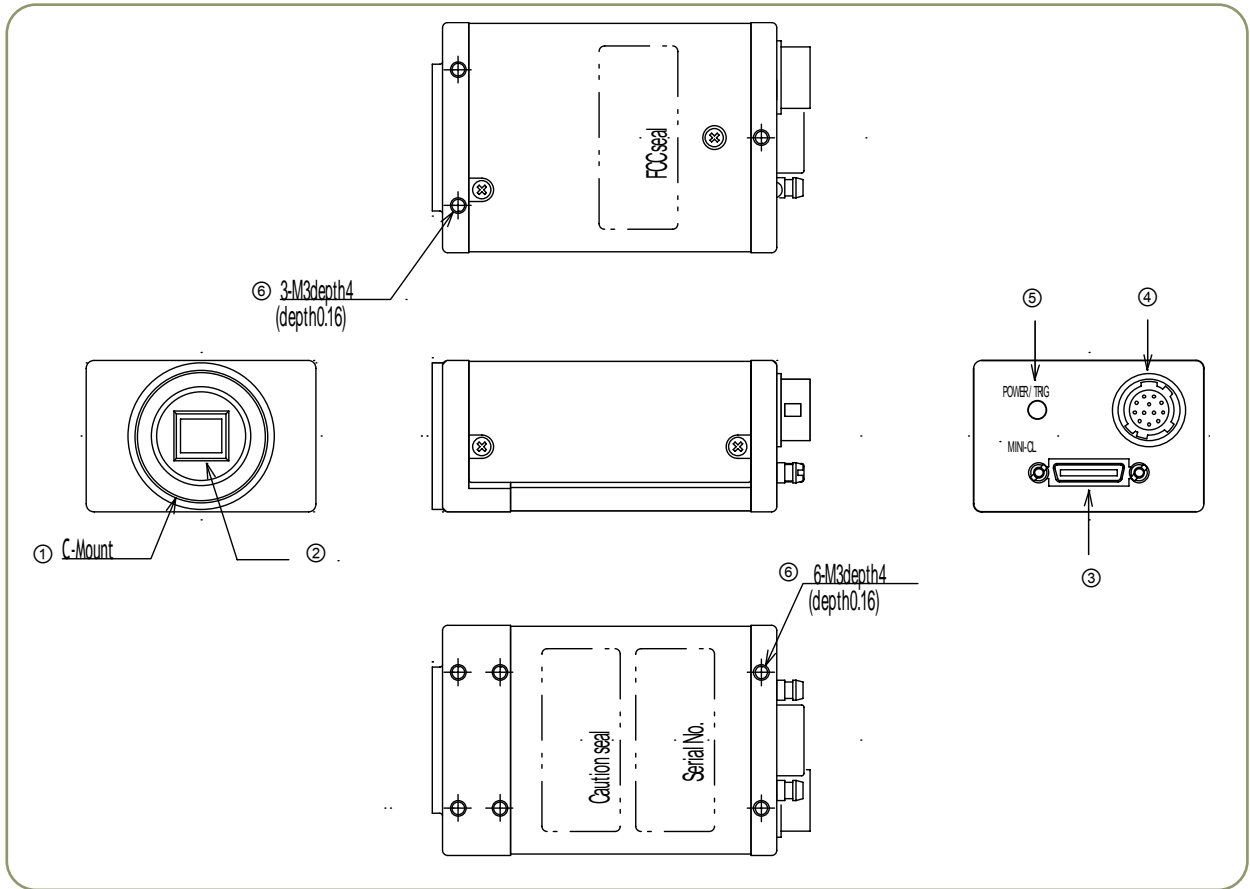

- | | |
|-----------------------|--|
| ① Lens Mount | C mount (Note *1) |
| ② CCD sensor | 1/2 inch CCD sensor |
| ③ 26P Multi Connector | Camera Link Interface (Miniature type) |
| ④ 12P Multi Connector | DC+12V and trigger input |
| ⑤ LED | Indication for power and trigger input |
| ⑥ Mounting holes | M3 depth 4mm for tripod mount plate |

*1) Note: Rear protrusion on C-mount lens must be less than 10.0mm.

Fig. 1. Locations

5. Pin Assignment

5.1. 12-pin Multi-connector (DC-IN/Trigger)

Type: HR10A-10R-12PB-01 (Hirose) male.

Use the part number HR10A-10P-12S for the cable side

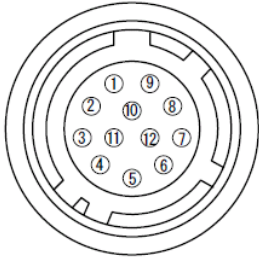

Fig. 2 Hirose 12-pin connector

Pin no.	Signal	Remarks
1	GND	
2	+12 V DC input	
3	GND	
4	Iris video	Only for Continuous mode. TR=0
5	GND	
6	NC	
7	NC	
8	GND	
9	XEEN out	
10	Trigger in	TI=1 (or Camera Link TI=0). *1)
11	DC+12V	
12	GND	

* Note: Factory default is trigger via Camera Link

5.2. Digital Output Connector for Mini-CL (Camera Link)

Type: 26-pin SDR connector (3M or Honda type)



Fig.3. 26-pin Mini-CL connector

Pin No	I/O	Name	Note
1,13,14,26		GND	DC GND
7(+),20(-)	I/O	RXD	Serial Communication
8(-),21(+)	O	TXD	
10(+),23(-)	I	Reserve	
9(-),22(+)	I	Trigger	CC1 Ext. Trigger input
6(-),19(+)	O	TxOUT3	Camera Link out
4(-),17(+)	O	TxOUT2	
3(-),16(+)	O	TxOUT1	
2(-),15(+)	O	TxOUT0	
5(-),18(+)	O	TxClock	Clock fo CL

5.3. Input and output circuits

In the following schematic diagrams the input and output circuits for video and timing signals are shown.

5.3.1. Iris video output

This signal can be used for lens iris control in Continuous mode.

The signal is taken from the CCD sensor output before the gain circuit. The video output is without sync. The signal is 0.7 V_{pp} from 75 Ω without termination.

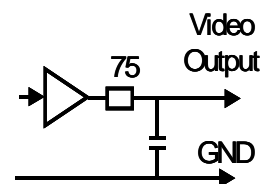

Fig. 4. Video output.

5.3.2. Trigger input

An external trigger input can be applied to pin 10 of 12-pin Hirose connector (when the command TI=1 has been set). The input is AC coupled. To allow long pulses the input circuit is designed as a flip-flop circuit. The leading and trailing edges of the trigger pulse activate the circuit.

The trigger polarity can be changed by TP=1.

Trigger input level 4 V ±2 V.

Trigger can also be applied through the Camera Link connector, when the command TI=0 has been sent.

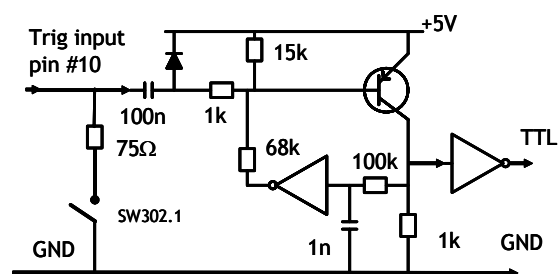

Fig. 5. Trigger input.

5.3.3. XEEN output

XEEN is on pin #9 on 12 pin HR connector. The output circuit is 75 Ω complementary emitter followers. It will deliver a full 5 volt signal.

Output level ≥4 V from 75Ω. (No termination).

EEN is also found in Camera Link.

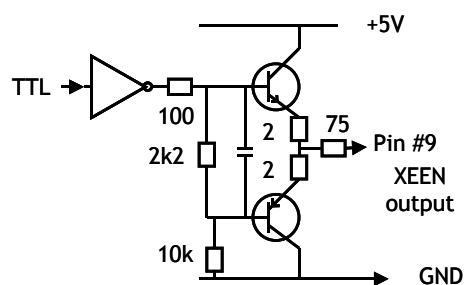

Fig. 6. XEEN output

5.3.4. Camera Link interface

The video output is Camera Link with 3 x 8 bit RGB video (or 10/8 bit raw video) placed in a base configuration. The digital output signals follow the Camera Link standard using Channel Link chip sets

The data bits from the digital video, FVAL, LVAL, DVAL and EEN are multiplexed into the twisted pairs, which are a part of the Camera Link. Trigger signals and the serial camera control are feed directly through its own pairs.

The 26 pin Mini MDR connector pin assignment follows the Camera Link base configuration.

For a detailed description of the Camera Link standard, please refer to the Camera Link standard specifications found on www.jai.com

6. Functions and Operations

6.1. Basic functions

The CM-140 MCL / CB-140 MCL cameras are progressive scan camera with 1.4 Mega pixels monochrome and Bayer mosaic color CCDs. The interface to the host PC is via digital Mini Camera Link (Mini-CL). Both models output video as 8 or 10 bits. The CB-140 MCL outputs raw Bayer video, requiring host based color interpolation.

An analogue iris-video signal can be used for controlling the iris of an auto-iris lens when operating in continuous mode.

The camera has 2/3, 1/2, 1/4 or 1/8 partial scanning and vertical binning (CM-140 MCL only) for faster frame rates.

There are 2 trigger modes in addition to continuous operation. The Pre-Select and Pulse Width control are available with a unique automatic LVAL sync or a-sync selection function.

Below the functions are described in detail.

6.1.1. Digital Video Output (Bit Allocation)

The 10-bit digital output is set 890 LSB as 100% video level when CCD output is 200mV.

The white clip level is set at 1023 LSB when CCD output is 230mV.

CCD out	Analogue level	Digital Out
Black	Setup 3.6%, 25mV	32LSB
200mV	700mV	890LSB
230mV	800mV	1023LSB

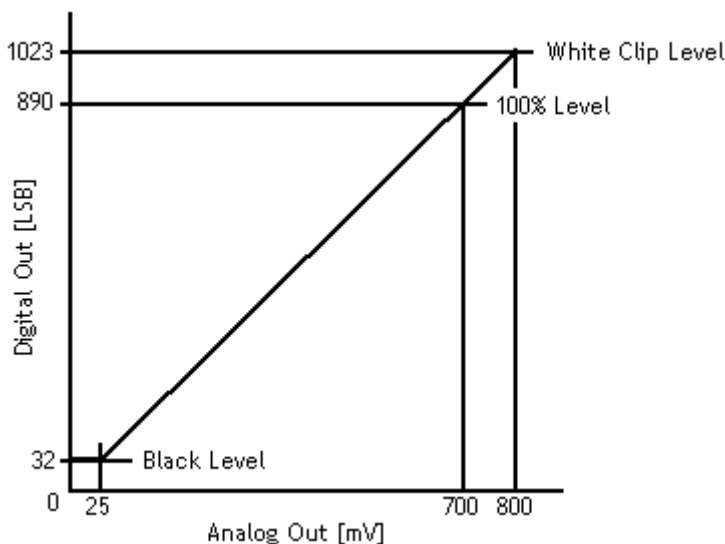

Fig.7. Digital Output Bit Allocation

6.1.2. Electronic Shutter

The CM/CB-140 MCL allows selecting shutter speed in two ways; preset shutter (10 fixed steps) and programmable exposure (in 1051 line period, LVAL, increments).

Preset Shutter

CM-140 MCL / CB-140 MCL

The following shutter speeds can be selected by command SH=0 through SH=9.
 OFF (1/31), 1/60, 1/100, 1/250, 1/500, 1/1000, 1/2000, 1/4000, 1/8000, 1/10000 seconds

Programmable Exposure (PE)

The exposure time can be programmed in 30.58µs (LVAL period) increments. The range is from 2 LVAL to 1052 LVAL.

Minimum exposure time 2L	Maximum exposure time 1052L
30.584µs x 2(L) = 61.168 µs	30.584µs x 1052 (L) ≈ 32.17ms

6.1.3. Continuous operation or triggered operation

The camera can operate in continuous operation applications not requiring asynchronous external trigger. This mode permits the use of a lens with video controlled iris. The camera will operate at its maximum frame rate, 31 frames/seconds in this mode.

For applications that require an external trigger, the camera can accept an external trigger input on pin 10 of the 12-pin Hirose connector or via the Camera Link interface. The command "TI" is used to switch between inputs.

The camera can operate up to 30 frames/second in triggered operation.

6.1.4. Iris video output.

The iris video output in pin #4 on 12 pin HR is 700 mV for 100% video out in Camera Link. The iris video signal is taken before the gain circuit. It is without sync.

The iris video signal can be used for auto iris lens drive in continuous mode.

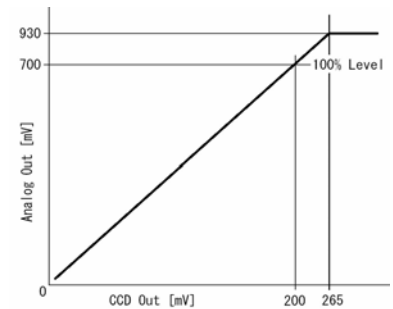
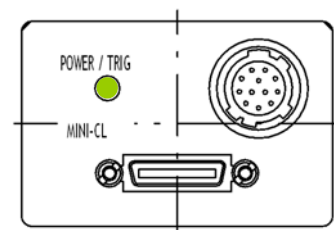

Fig. 22. Iris video output.

6.1.5. Rear panel indicator.

The rear panel mounted LED provides the following information:

- Amber: Power connected - initiating
- Steady green: Camera is operating in Continuous mode
- ★ Flashing green. The camera is receiving external trigger



6.1.6. Auto-detect LVAL-sync / a-sync. accumulation

This function replaces the manual setting found in older JAI cameras. Whether accumulation is synchronous or a-synchronous in relationship to LVAL depends on the timing of the trigger input.

When trigger is received while FVAL is high (during readout), the camera works in LVAL-synchronous mode, preventing reset feed trough in the video signal. There is a maximum jitter of one LVAL period from issuing a trigger and accumulation start.

When trigger is received when FVAL is low, the cameras works in LVAL-asynchronous mode (no delay) mode.

This applies to both pre-select (PS) trigger mode and pulse width trigger (PW) mode.

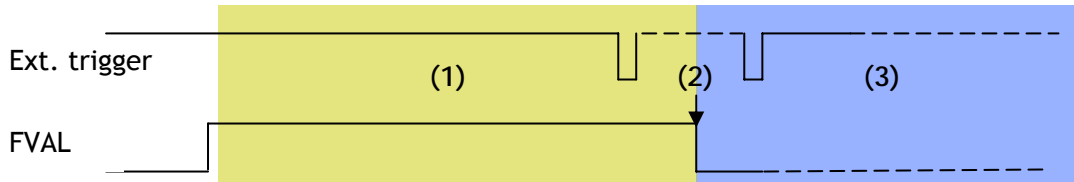

- (1) In this period camera executes trigger at next LVAL (prevents feed-through noise)
- (2) Avoid trigger at FVAL transition (+/- 1 LVAL period), as the function may randomly switch between "next LVAL" and "immediate".
- (3) In this period camera executes trigger immediately (no delay)

Fig. 8. Auto-detect LVAL sync /async accumulation

6.1.7. Starting pixel - Bayer color mosaic

The CB-140MCL is a color camera based on a CCD sensor with a Bayer color mosaic.

The color image reconstruction is done in the host PC.

The color sequence in the video signal differs from full scanning to partial scanning. The right hand drawing shows the color sequence at the image start.

The starting line number is shown from LVAL. The first active pixel is offset 7 pixels from LVAL, when DVAL rises.

Even lines starts with GBG.
Odd lines starts with RGR

See also chapter 6.3, Partial Scan

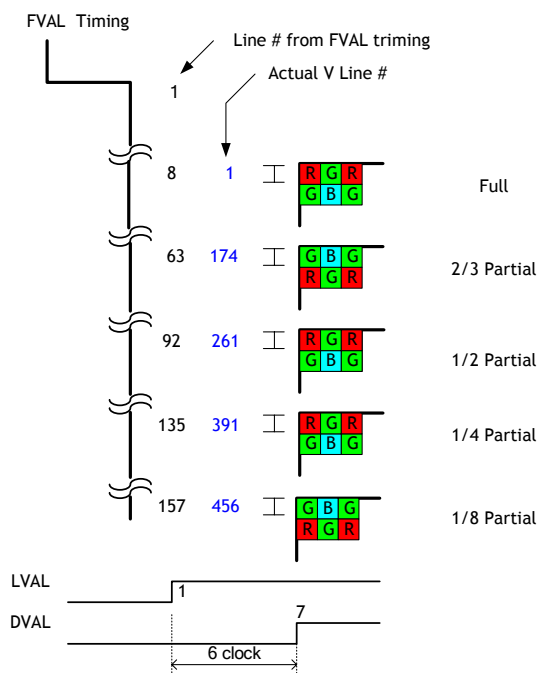

Fig. 9. CB-140MCL Bayer RGB color sequence.

6.1.8. Vertical Binning

This function is only available on the CM-140MCL camera.

Binning mode (Command VB) is a function where the signal charge from 2 adjacent (vertical) pixels are added together and read out as one pixel. Binning results in half vertical resolution and higher frame rate. By adding 2 pixels together, the sensitivity is doubled. The charge accumulated in 2 adjacent lines is added together in the horizontal CCD register. This is done by providing two pulses to the vertical CCD register for each line readout. Vertical binning can not be used together with the Partial scan.

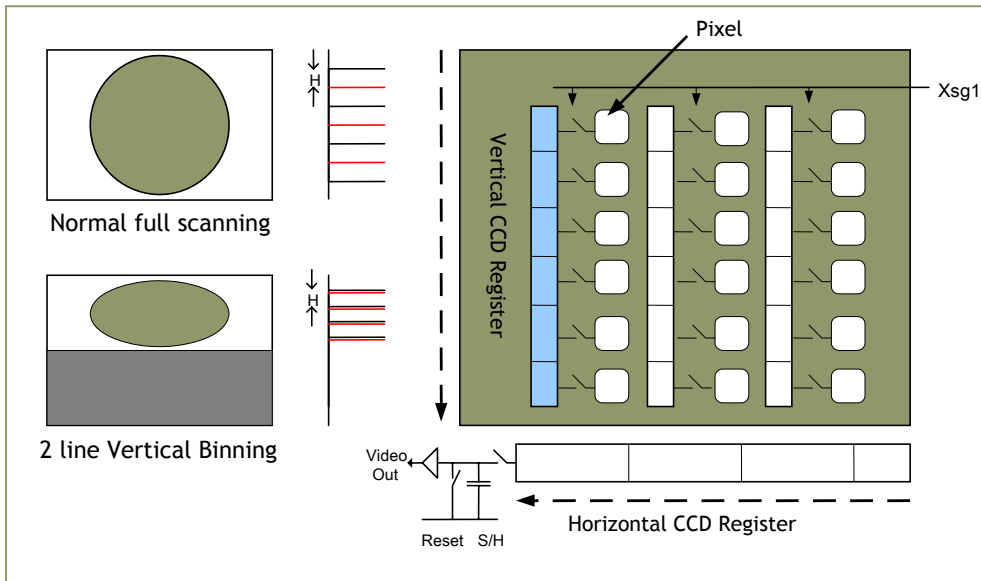

Fig. 10. Vertical Binning

6.2. Sensor Layout and timing

6.2.1. CCD Sensor Layout

The CCD sensor layout with respect to pixels and lines used in the timing and video full frame read out is shown below. For Bayer color sequence, refer to chapter 6.1.3.

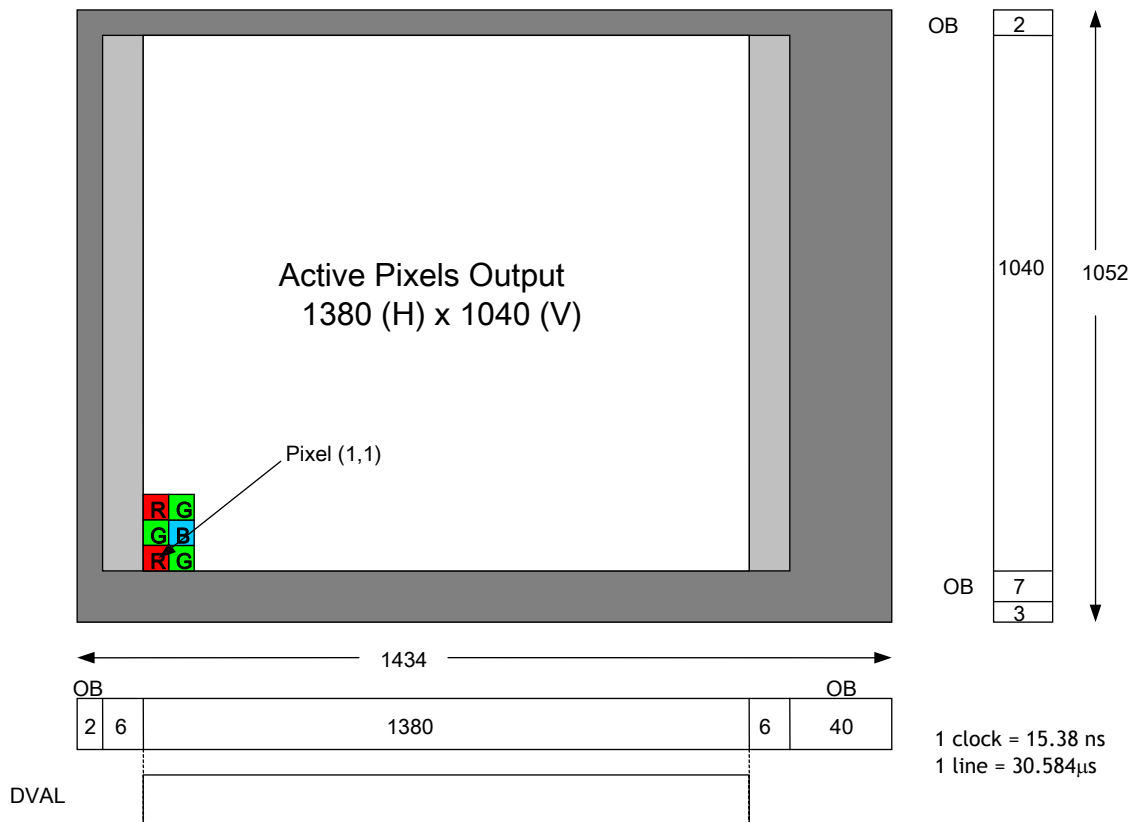

Fig. 11. CCD sensor layout

6.2.2. Horizontal timing

The LVAL period is shown for continuous mode.

Horizontal Video Timing Full Frame Read out / Partial Read Out
 1 LVAL 1988 clk = 30.584 μ s
 1 clk = 15.38 ns

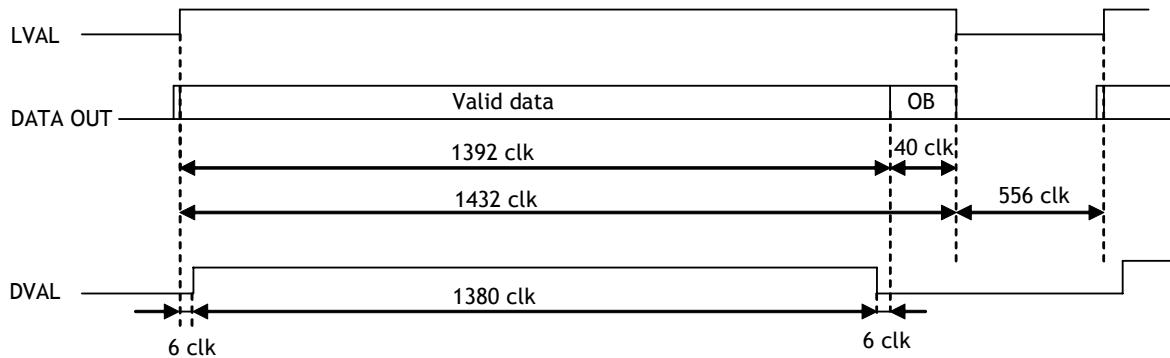

Fig. 12. Horizontal timing

6.2.3. Vertical timing

The FVAL period for continuous mode full scan is shown.

Vertical Video Timing Full Frame Read out
 Frame rate : 1052L 31.08fps

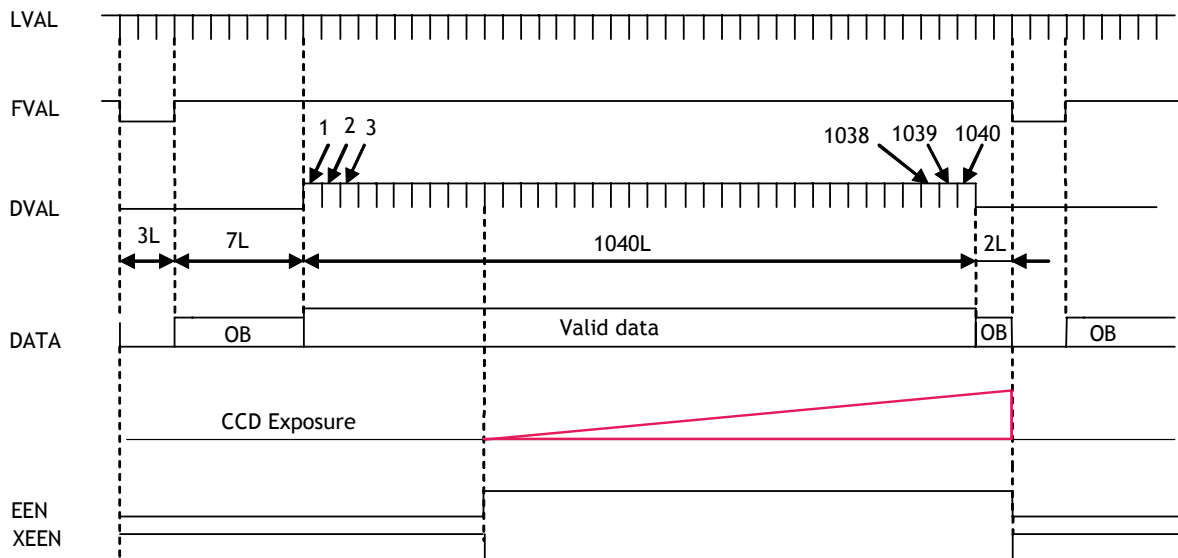
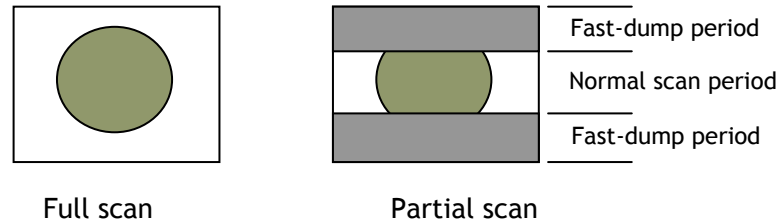

Fig. 13. Vertical timing for full scan

6.2.4. Partial Scan

Partial scan allows higher frame rate by reading out a smaller center portion of the image. This is particularly useful when inspecting objects that do not fill the whole height of the image.



Vertical Timing

The below diagram and table provide vertical timing information for the fixed partial scan settings 1/2, 1/4, 1/3 and 2/3

Vertical Video Timing Partial Frame Read out

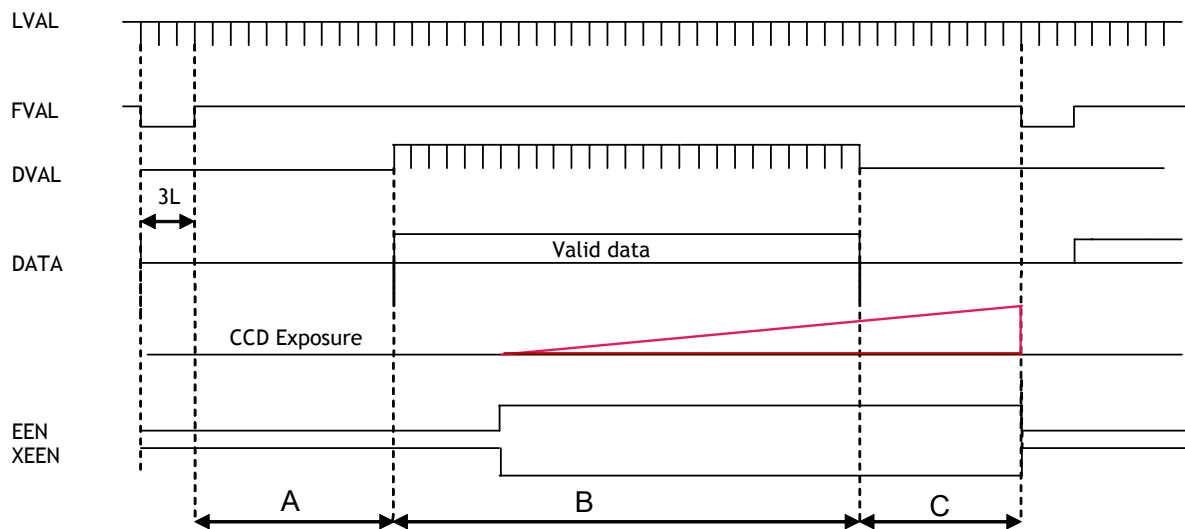

Values for vertical timing in partial scan continuous mode.

AREA	FVAL Low (L)	A (L)	B (L)		C (L)	Total line (L)	frame rate (L)
			Start line	End line			
1/2	3	91	520		88L	702L	46.57
			261	780			
1/4	3	134	260		131L	528L	61.92
			391	650			
1/8	3	156	130		153L	442L	73.97
			456	585			
2/3	3	62	694L		59L	818L	39.97
			174	867			

Remark! The color sequence for CB-140MCL differs in partial scan. Refer to chapter 6.1.2.

Fig. 14. Vertical timing for partial scanning

CM-140 MCL / CB-140 MCL

Horizontal Timing

The horizontal timing is the same the full scanning.

Horizontal Video Timing Full Frame Read out / Partial Read Out
 1 LVAL 1988 clk = 30.584 μ s
 1 clk = 15.38 ns

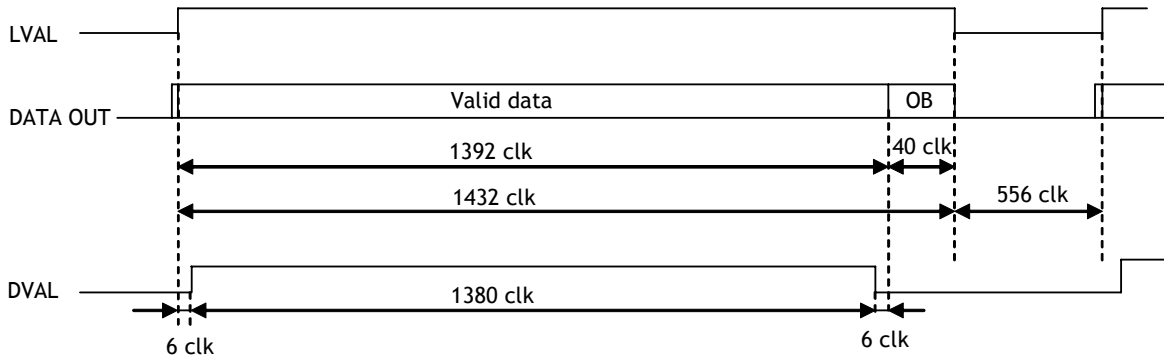

Fig. 15. Horizontal timing for partial scanning

6.2.5. Vertical Binning

Vertical binning combines charge from two adjacent lines, reducing the vertical resolution to half and at the same time increasing frame rate and sensitivity. By activating this function, the frame rate is increased to 48.87 fps.

This function is available only for CM-140MCL.

Important Note

Vertical Binning can not be used together with the Partial Scanning.

Horizontal Timing

Horizontal Video Timing V Binning
 1 LVAL 2524 clk = 38.83 μ s
 1 clk = 15.38 ns

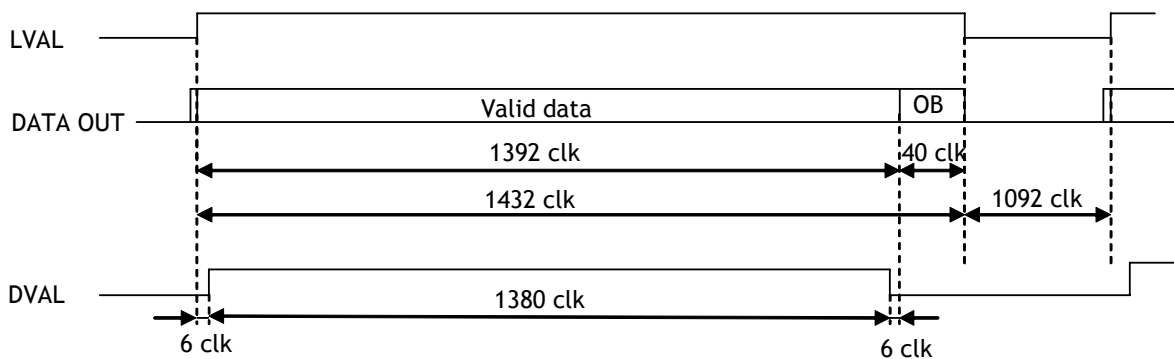

Fig.16. Horizontal Timing for Vertical Binning

Vertical timing

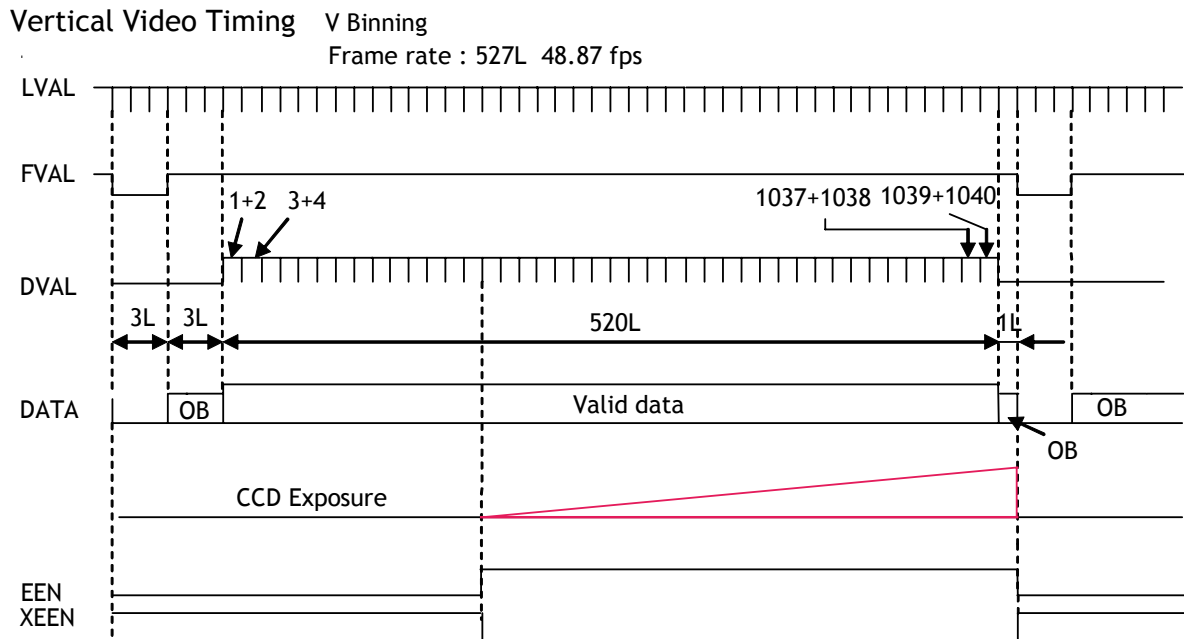

Fig.17. Vertical Timing for Vertical Binning

6.3. Operation Modes

This camera can operate in 3 primary modes.

1. TR=0 Continuous Mode. Pre-selected exposure.
2. TR=1 Edge Pre-select Mode. Pre-selected exposure.
3. TR=2 Pulse Width Control Mode. Pulse width controlled exposure.

6.3.1. Continuous operation

For applications not requiring asynchronous external trigger, but should run in continuous operation, this mode is used.

For timing details, refer to fig. 12 through fig. 17.

To use this mode:

Set function:	Trigger mode to "Continuous".	TR=0
	Scanning	SC=0 through 4
	V Binning	VB=0 or 1
	Shutter mode pre-set or programmable	SM=0 or 1
	Shutter speed	SH=0 to 9
	Programmable exp.	PE=2 to 1052
	Other functions and settings	

6.3.2. Pre-select Trigger Mode

An external trigger pulse initiates the capture, and the exposure time (accumulation time) is defined by the SH or PE commands.

The resulting video signal will start to be read out after the selected shutter time.

For timing details, refer to fig. 12 through fig. 17 and fig. 18 & 19.

CM-140 MCL / CB-140 MCL

To use this mode:

Set function:	Trigger mode to “Edge pre-select”. Scanning V Binning Shutter mode to pre-set or programmable Shutter speed Programmable exp. Other functions and settings	TR=1 SC=0 to 4 VB=0 or 1 SM=0 or 1 SH=0 to 9 PE=2 to 1052
Input:	Ext. trigger. Camera Link or 12-pin Hirose TI=0, TI=1	

Important notes on using this mode

1. The minimum trigger interval > 1 LVAL.
2. Depending on the timing of the leading edge of the trigger pulse in relationship to FVAL, accumulation will be synchronous or a-synchronous in relationship to LVAL. See chapter 6.1.1 for details.

LVAL_sync timing

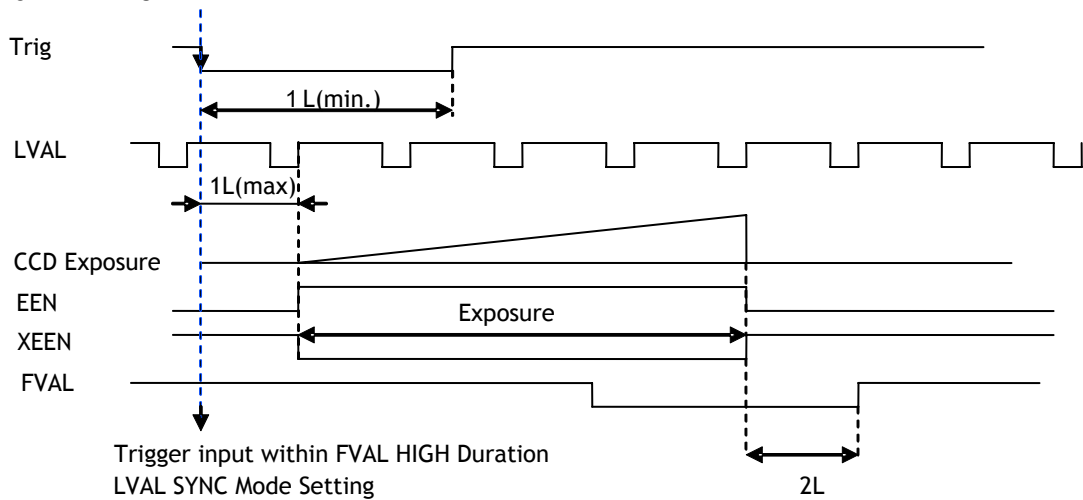

Fig. 18. Pre-select trigger mode. LVAL synchronized.

LVAL_a-sync timing

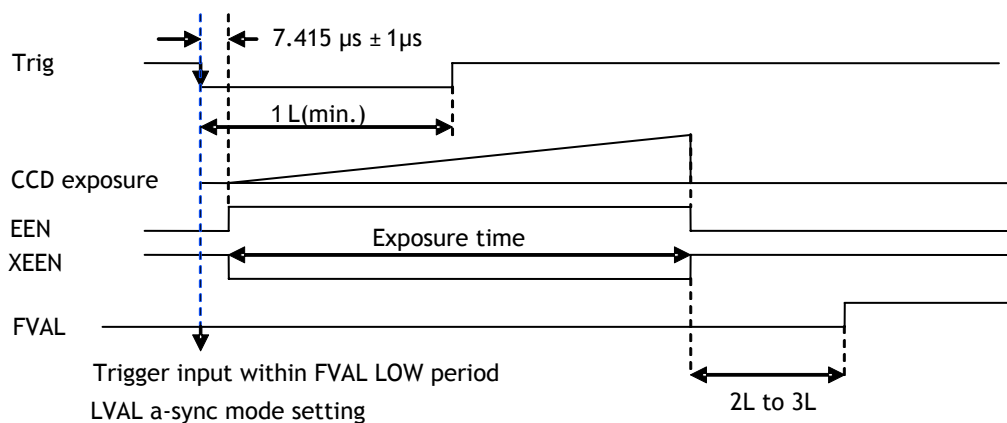

Fig.19. Pre-select trigger mode. LVAL a-synchronous

6.3.3. Pulse Width Control Trigger Mode

In this mode the accumulation time is equal the trigger pulse width. Here it is possible to have long time exposure. The maximum recommended time is <60 frames.

For timing details, refer to fig. 12 through fig. 17 and fig. 20 & 21.

To use this mode:

Set function:	Trigger mode to "Pulse width control".	TR=2
	Partial scan	SC=0 to 4
	Vertical binning	VB= 0 or 1
	Other functions and settings	
Input:	Ext. trigger. Camera Link or 12-pin Hirose TI=0, TI=1	

Important notes on using this mode

1. The minimum trigger interval > 1 LVAL
2. Depending on the timing of the leading edge of the trigger pulse in relationship to FVAL, accumulation will be synchronous or a-synchronous in relationship to LVAL. See chapter 6.1.1 for details.

LVAL_sync timing

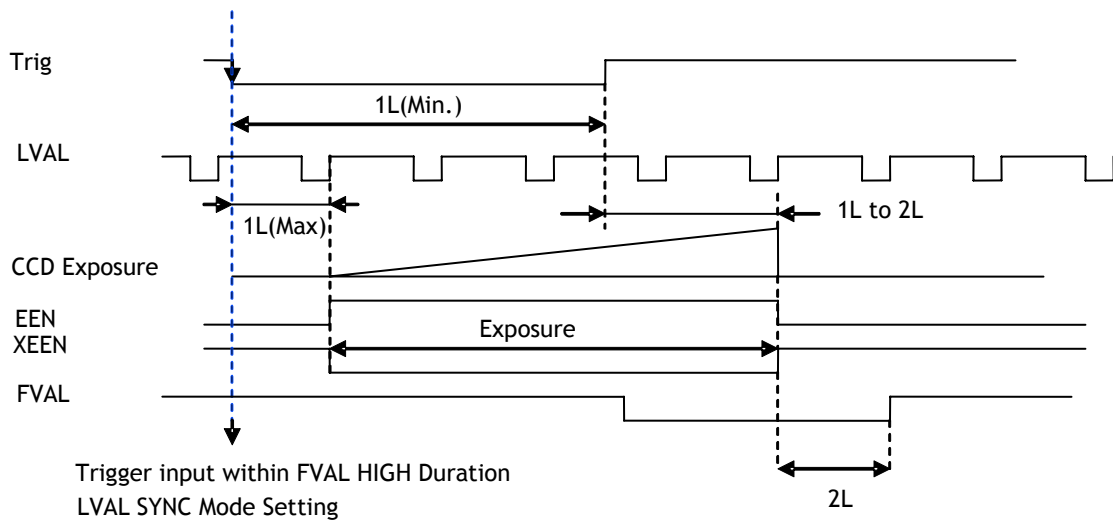

Fig. 20. Pulse width trigger mode. LVAL synchronized.

LVAL_a-sync timing

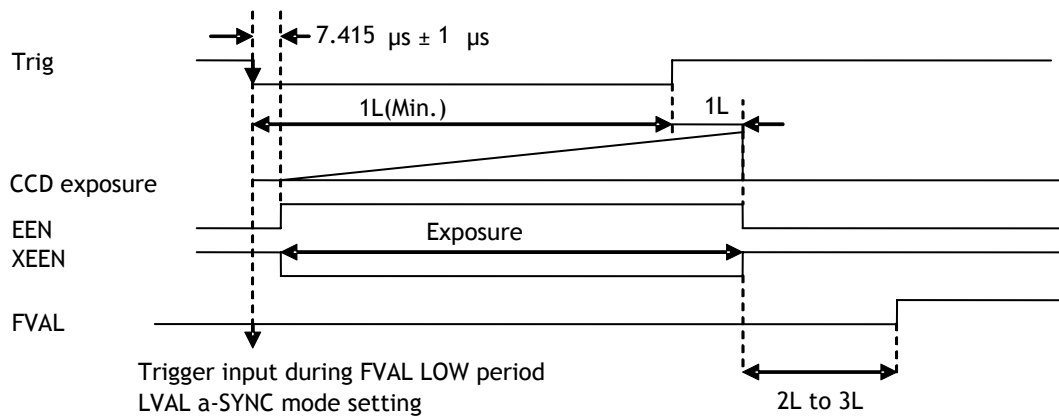

Fig.21. Pulse Width trigger mode. LVAL a-synchronous

6.4. Mode and function matrix.

The following table shows which functions will work in the different modes for CM-140MCL / CB-140MCL.

Func. Trigger Mode		Shutter		Partial scan	V Binning	Accumulation LVAL sync/async	Iris video out
		Pre-select	Programmable				
Cont.	TR=0	Yes	Yes	Yes	Yes	-	Yes
EPS	TR=1	Yes	Yes	Yes	Yes	Auto	-
PWC	TR=2	-	-	Yes	Yes	Auto	-

Fig. 23. Mode and function matrix.

7. Configuring the Camera

7.1. RS-232C control

All configuration of the CV-M71 CL camera is done via the RS-232C port on the 12 pin HR connector or via Camera Link. (Internal switch SW301-1 on for HR). The camera can be set up from a PC running terminal emulator software, or using JAI's camera control software. Below is the description of the ASCII based short command protocol.

Communication setting.

Baud Rate	9600 bps
Data Length	8 bit
Start Bit	1 bit
Stop Bit	1 bit
Parity	None
Xon/Xoff Control	None

RS 232C cable

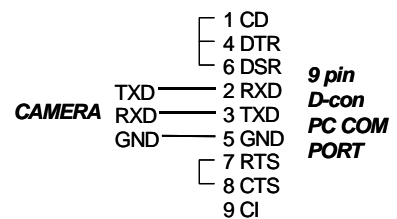

Protocol.

Transmit setting to camera:

NN=[Parameter]<CR><LF> (NN is any kind of command. Capital or small letters.)

The camera answers:

COMPLETE<CR><LF>

To have all communication visible on the emulator screen, start with:

EB=1<CR><LF>

The camera answers:

COMPLETE<CR><LF>

Transmit request command to camera:

NN?<CR><LF> (NN is any kind of command.)

The camera answers:

NN=[Parameter]<CR><LF>

Transmit the following to have the camera actual setting:

ST?<CR><LF>

The camera answers:

A complete list of the current settings

Transmit the following to have a command list:

HP?<CR><LF>

The camera answers:

A list with all commands and possible settings

Invalid parameters send to camera: (99 is an invalid parameter)

SH=99<CR><LF>

The camera answers:

02 Bad Parameters!!<CR><LF>

To see firmware number.

VN?<CR><LF>

To see camera ID. It shows the manufacturing lot number.
ID?<CR><LF>

7.2. Setting functions

7.2.1. Bit allocation. BA=0, BA=1

This command sets the output for either 8-bit or 10-bit.

7.2.2. Partial scan. SC=0 through 4.

The CCD scanning format can be selected between full or partial scanning. With partial scanning only the vertical central part of the CCD sensor is read out with a higher frame rate. The partial scan is done by a fast dump read out of the lines in the vertical CCD register down to the top of the partial image. This central part of the image is read out with normal speed. The lines below the partial image are read out and dumped with a high speed.

Note: The color sequence for CB-140 MCL differs in partial scan modes. Refer to chapter 6.1.2.

7.2.3. Vertical binning Binning. VB=0, VB=1

This function is only for CM-140MCL camera.

The CM-140MCL has only vertical binning mode. With V binning the pixel charge from 2 adjacent lines are added together in the horizontal CCD register. It is done by double pulses to the vertical CCD register. V Binning can not be used together with the Partial scanning.

7.2.4. Shutter mode. SM=0 and SM=1

With SM=0 this function selects the shutter from the 9 fixed steps (SH=0 through SH=9SH).
With SM=1 from programmable in 1051 steps (PE=2 through PE=1052).

7.2.5. Trigger input select. TI=0, TI=1.

This function selects the trigger input to be through Camera Link (TI=0), or as TTL through the 12 pin Hirose connector (TI=1).

7.2.6. Trigger polarity. TP=0, TP=1.

The active trigger polarity is normal low (TP=0). It can be invert it to active high (TP=1).

7.2.7. Gain level. GA=-84 through +336.

GA=0 is 0dB gain, which is normal working point. The range is from -3 dB to +12 dB.

7.2.8. Black level. BL=0 through BL=1023.

Black level (or set-up level) will set the video level for black. Factory setting is 32 LSB for 10bit or 8 LSB for 8bit.

7.3. Save and Load Functions.

The following commands are for store and load camera settings in the camera EEPROM.

CM-140 MCL / CB-140 MCL

Load settings. LD.

This command will load previous stored settings to the camera. 3 user settings can be stored in the camera EEPROM. 1 factory setting is also stored in the camera. The settings stored in the last used user area is used as default settings at power up.

Save Settings. SA.

This command will store the actual camera settings to 1 of the 3 user area in the camera EEPROM.

EEPROM Area. EA.

If received, the camera will return the last used user area number.

7.4. CM-140MCL / CB-140MCL command list

	Command Name	Format	Parameter	Remarks
A - General settings and utility commands.				
1	Echo Back	EB=[Param.]<CR><LF> EB?<CR><LF>	0=Echo off 1=Echo on	Off at power up
2	Camera Status Request	ST?<CR><LF>		Actual setting
3	Online Help Request	HP?<CR><LF>		Command list
4	Firmware Version	VN?<CR><LF>		3 digits (e.g.) 100 = Version 1.00
5	Camera ID Request	ID?<CR><LF>		max 10 characters
6	Model Name Request	MD?<CR><LF>		max 16 characters
7	User ID	UD=[Param.]<CR><LF> UD?<CR><LF>		User can save and load free text.(16 or less characters)
B - Shutter				
1	Shutter Mode	SM=[Param.]<CR><LF> SM?<CR><LF>	0=Preset Shutter 1=Programmable exposure	
2	Preset Shutter	SH=[Param.]<CR><LF> SH?<CR><LF>	0=Off, 1=1/60, 2=1/100, 3=1/250, 4=1/500, 5=1/1000, 6=1/2000, 7=1/4000, 8=1/8000, 9=1/10000	Available when SM=0.
3	Programmable Exposure	PE=[Param.]<CR><LF> PE?<CR><LF>	2 to 1052 (CM/CB-140)	Available when SM=1.
C - Trigger mode				
1	Trigger Mode	TR=[Param.]<CR><LF> TR?<CR><LF>	0=Normal (Continuous) 1=EPS(Edge pre select)	

CM-140 MCL / CB-140 MCL

	Command Name	Format	Parameter	Remarks
			2=PWC(Pulse width control)	
2	Trigger Polarity	TP=[Param.]<CR><LF> TP?<CR><LF>	0=Active Low 1=Active High	
3	Trigger Input	TI=[Param.]<CR><LF> TI? <CR><LF>	0=Camera Link 1=Hirose 12pin	
D -Image Format				
1	Bit Allocation	BA=[Param.]<CR><LF> BA?<CR><LF>	0=10bit 1=8bit	
2	Scan Format	SC=[Param.]<CR><LF> SC? <CR><LF>	0=Full Frame 1=2/3 Partial 2=1/2 Partial 3=1/4 Partial 4=1/8 Partial	
3	V-Binning	VB=[Param.]<CR><LF> VB?<CR><LF>	0=OFF 1=On	Only for CM-140MCL
E - Gain, Black and signal settings				
1	Gain Level	GA=[Param.]<CR><LF> GA?<CR><LF>	-84 to 336	
2	Black Level	BL=[Param.]<CR><LF> BL?<CR><LF>	0 to 1023	
F - Saving and loading data in EEPROM				
1	Load Settings (from Camera EEPROM)	LD=[Param.]<CR><LF>	0=Factory area 1=User 1 area 2=User 2 area 3=User 3 area	Latest used DATA AREA becomes default at next power up.
2	Save Settings (to Camera EEPROM)	SA=[Param.]<CR><LF>	1=User 1 area 2=User 2 area 3=User 3 area Note : parameter 0 is not allowed	
3	EEPROM Current Area No Request.	EA?<CR><LF>	0=Factory area 1=User 1 area 2=User 2 area 3=User 3 area	The camera return the latest used DATA AREA.

NOTE: Do not try to use commands not shown in this list.

8. Camera Control Tool for CM-140 MCL / CB-140 MCL

The Camera Control Tool for Windows 2000/XP can be downloaded from www.jai.com. The control tool contains a camera control program and a developer's kit for integrating the control tool in your own software. For the integrator and experienced user, the Camera Control Tool is much more than a program with a window interface. It also provides an easy and efficient ActiveX interface built for MS Windows 2000/XP. The OCX interface has the ability to connect to the camera using the serial interface of the PC by reading and writing properties for the camera. This integration requires simple programming skills within Visual Basic, Visual C++ or similar languages in a Microsoft Windows environment.

8.1. Camera Control Tool Interface

The Camera Control Tool Software is based on a main Tool Bar and a number of associated Tool Windows. Each button in the Tool Bar pops up a separate Tool Window when pressed. The layout of the program can be adjusted by arranging the windows the way it is preferred. The program will store this information and recreate this layout, when the program is restarted. All Camera Control Tools have a Communication Window and an About Window. The other window(s) contains camera control commands.

8.1.1. Camera Control Tool Bar

This is a Camera Control Tool Bar and when the button of each window, each control GUI can be initiated.

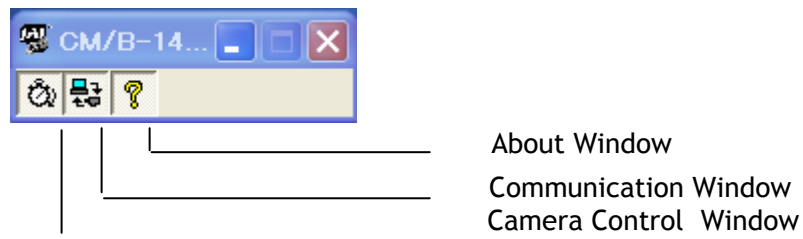

8.2. The About Window

The about window contains a picture of the camera and information about the version of the program, Internet connection to JAI A/S and access to the help documents.

The drop-down box labelled "Help File" will list all files which have the extension .pdf and that are found in the program (default) folder.

C:\Program Files\JAI A-S\"control tool name"

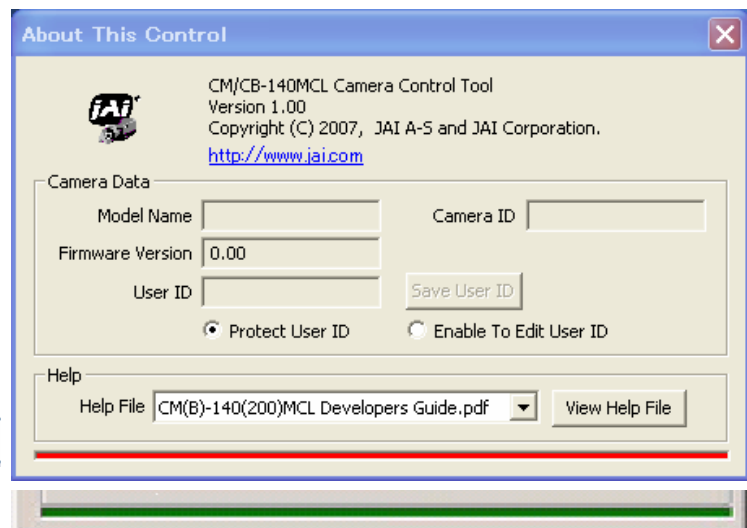

It is possible to download updated operation manuals from the jai website:

<http://www.jai.com/camera/manuals.asp/sprog=uk>

An updated manual can be saved in the folder address mentioned above and it will automatically be included in the list of help files.

CM-140 MCL / CB-140 MCL

At the bottom of the windows (all windows but the Communication Window is a colored bar. The bar is green when the Camera Control Tool is connected to a camera and the camera is turned on. The bar is red when the Camera Control Tool is not connected to a camera or when the camera is turned off.

8.3. Communication Window

The Communication Window is used to connect the Camera Control Tool with the JAI camera.

Camera Link communication:

The 'CL Manufacturer/COM-ports' list box also contains DLL file names (or frame grabber names) for all Camera Link frame grabbers that are installed in the pc. This is done by using a DLL file called "clserial.dll" to upload all frame grabber DLLs that are found in the pc.

Just select the option for the frame grabber that is installed in the pc.

Auto search

Click the auto button to search for a camera on communication port 1 to 16. The camera control program automatically sends camera request on every communication port. The user is prompted to use a communication port if a camera answers the request.

This button is only used for RS-232 communication.

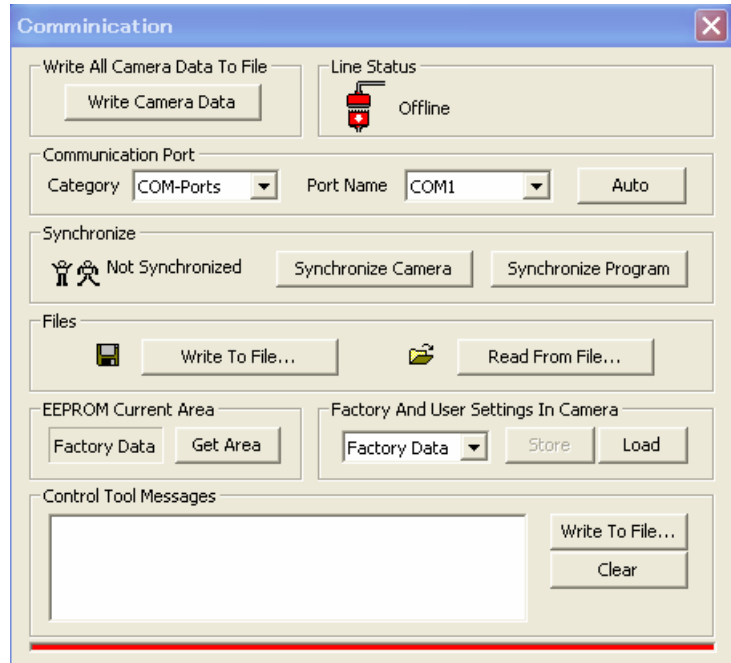

Off/On-line mode

The Camera Control Tool Application can run Offline (without a camera attached) and all functions are fully functional in offline mode.

Off line mode is indicated in The Communication Window, where a status field with graphic and text indicates the on/off-line status.

Changing the selected communication port (from the communication window) changes the online/off-line status. If a camera is found on the selected communication port the application runs online otherwise offline.

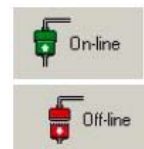

Changing the settings in the application will automatically update the camera settings when the application is online.

If the application loses connection with the camera it will automatically go to offline mode and it is indicated in the communication window.

Synchronize program and camera

The Camera Control software has the ability to synchronize either the camera or the program. Click Synchronize camera to write all settings from the program to the camera or click the Synchronize program to load all settings from the camera to the program.

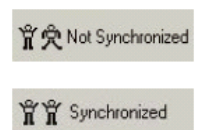

Files

CM-140 MCL / CB-140 MCL

When clicking the Write to File or Read from File button, the user is prompted for a file using a standard file dialog. New files are created if they do not already exist.

Files for camera settings have the extension cam. Information about the communication port is not stored in the files. All settings are automatically sent to the camera when a file has been loaded (if the camera is online).

Factory and User Settings

Use the Store button to store the current camera settings into the user settings area in EEPROM. Current camera settings are not saved when the camera is turned off. To save current camera settings you have to save them on the available user areas.

Use the Load button to restore previously saved camera settings from either the Factory or the User EEPROM area.

Write All Camera Data to File.

Click the “Write Camera Data” button to save all camera settings into a text file. The information that can be saved is:

Model Name, Camera ID, User ID, Firmware Version, Current Settings, Factory Settings and the available User Areas.

The file is formatted as shown in the picture below:



EEPROM Current Area.

Click the ‘Get Area’ button to read the power up settings area number.

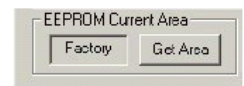

8.4. Camera Control Window

The Camera Control Window contains the fundamental camera setting functions.

It is possible to set the shutter mode, Trigger mode, image format, scan format, gain control and black setting.

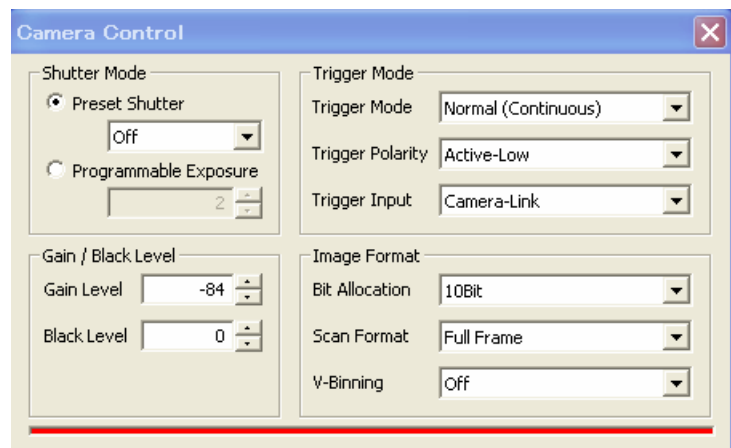

8.5. Using the Camera Control Tool

Here is some practical information about the Camera Control Tool:

1. The Camera Control Tool bar is always on top of other windows.
2. When you minimize the Camera Control Tool bar all open windows will close.
3. It is possible to work with the Camera Control Tool when the camera is online and when the camera is offline.
4. The newer JAI cameras always start up with the last used user area (but for some old models it will start up with the last saved user area.)
5. The Camera Control Tool saves the last used settings (not the user area), which don't have to be the same as for the last saved user area.

CM-140 MCL / CB-140 MCL

6. The setup file 'CameraName.ini' stores all information about camera settings. When the program is started the last settings for the program are loaded from the file 'CameraName.ini'
7. When you turn on the camera and the Camera Control Tool, it is possible that the Camera Control Tool does not show the actual camera settings (see 4. and 5.).
 - a. To obtain the camera settings click "Synchronize Program".
 - b. To send the settings that are saved in the Camera Control Tool (last used settings) to the camera click "Synchronize Camera".
 - c. To see which area the camera has started up in click "Get Area".

9. External Appearance and Dimensions

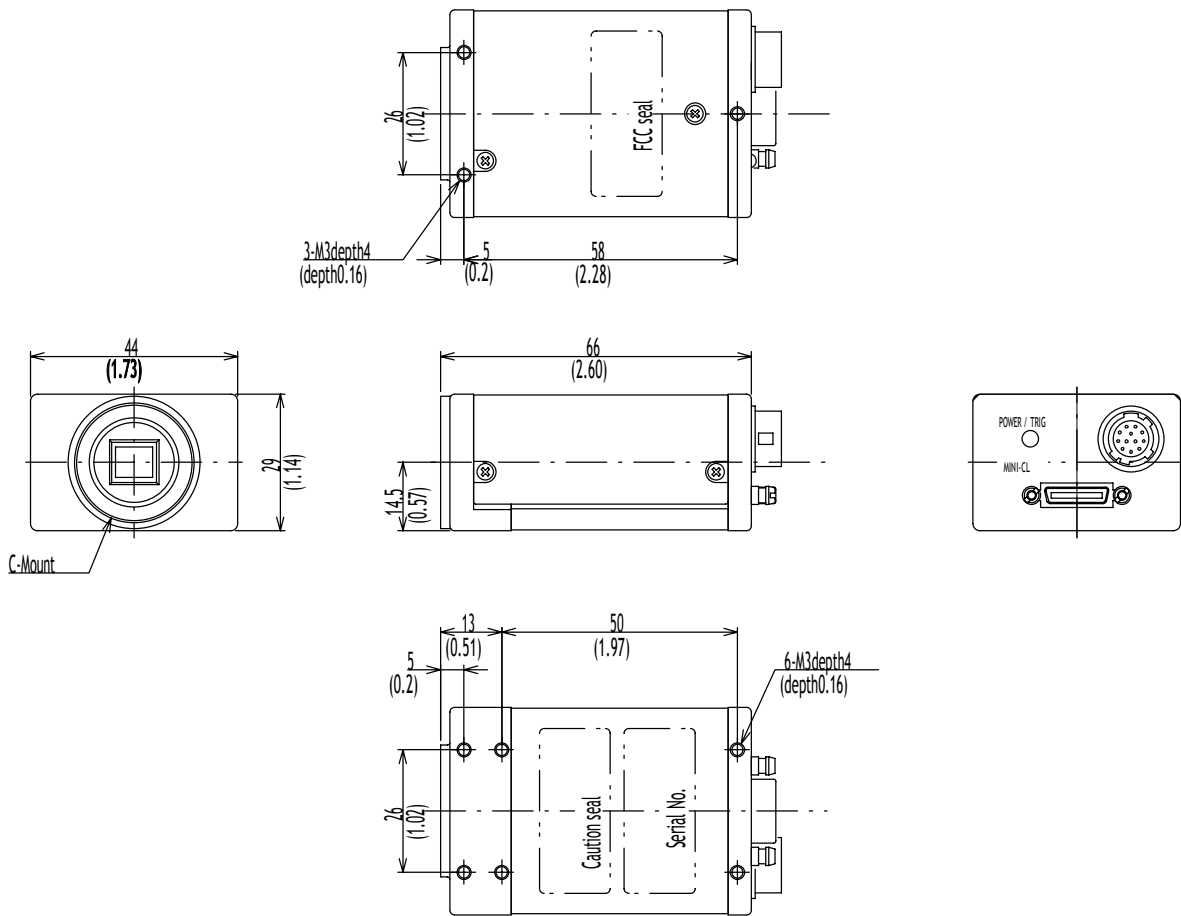

Fig. 25. Outline.

10. Specifications

10.1. 10.1. Spectral sensitivity

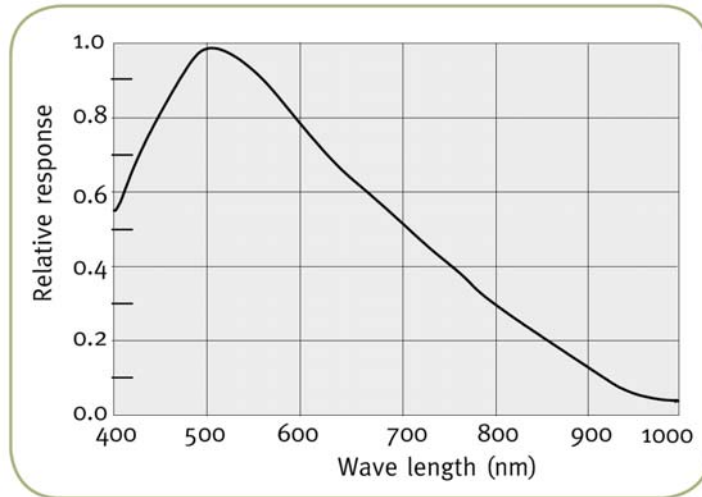

Fig. 26. Spectral sensitivity for CM-140MCL

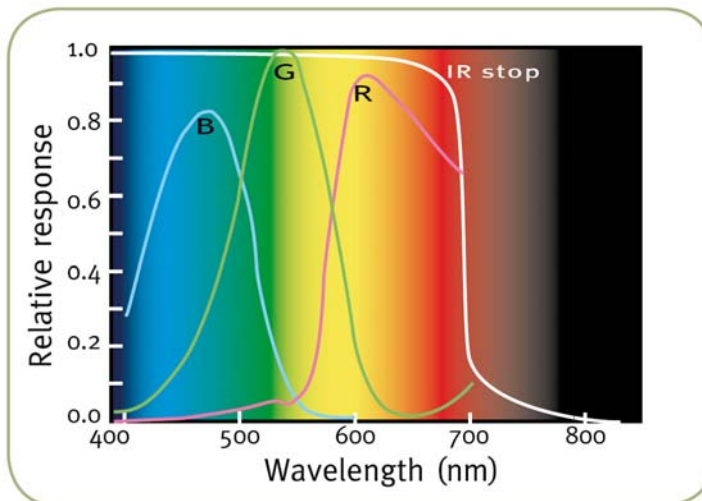

Fig.27. Spectral Sensitivity for CB-140MCL

CM-140 MCL / CB-140 MCL

10.2. Specification table

Specifications	CM-140 MCL	CB-140 MCL
Scanning system	Progressive scan	
Frame rate full frame	31.08 frames/sec. Progressive (1052 lines/frame)	
Pixel clock	65 MHz	
Line frequency	32.681kHz (1988 pixels clock/line)	
CCD sensor	1/2". Monochrome ICX267AL	1/2" Color ICX-267AK
Sensing area	6.4 (h) x 4.8 (v) mm	
Cell size	4.65 (h) x 4.65(v) μ m	
Effective pixels	1380 (h) x 1040 (v)	
Pixels in video output. Full 2/3 partial 1/2 partial 1/4 partial 1/8 partial	1380 (h) x 1040 (v) 31.08 fps. H = 32.681 kHz 1380 *h(x 694 (v) 40.07 fps H= 32.681 kHz 1380 (h) x 520(v) 46.71 fps. H = 32.681 kHz 1380 (h) x 269 (v) 61.12 fps. H = 32.681 kHz 1380 (h) x 130 (v) 74.31 fps. H = 32.681 kHz	
Sensitivity on sensor (minimum)	0.6 Lux (Max. gain, Shutter OFF,50% video)	TBD Lux (Max. gain, Shutter OFF,50% Green, w/IR cut filter)
S/N ratio	More than 50 dB (0dB)	
Digital Video output.	8 or 10 bit in Camera Link	8 or 10 bit raw Bayer video in Camera Link
Iris video output. Analogue	0.7 Vpp	
Gain	Manual -3 to +12 dB	
Gamma	1.0	
Synchronization	Int. X-tal.	
Trigger input. TTL Camera Link	4 V \pm 2 V. TTL Via Camera Link	
EEN output	4 V from 75 Ω source	
Trigger modes	Edge Pre-Select and Pulse Width Control	
Accumulation	LVAL synchronous or a-synchronous automatic selection	
Preset Shutter speed	9 fixed steps 1/60 to 1/10,000 second	
Programmable exposure	2 L to 1052 L (61.168 μ s to 32.17 ms)	
Pulse width control	1 L to 60 frames.	
Readout modes	Full, Partial scan.(2/3,1/2, 1/4, 1/8.) V Binning	Full, Partial scan.(2/3,1/2, 1/4, 1/8.)
Control interface	RS 232C or Camera Link	
Functions controlled by RS 232C	Shutter, Trigger, Scanning, Read out, Polarity, Black level, Gain,	
Operating temperature	-5°C to +45°C	
Humidity	20 - 90% non-condensing	
Storage temp/humidity	-25°C to +60°C/20% to 90% non-condensing	
Vibration	10G (20Hz to 200Hz, XYZ)	
Shock	70G	
Regulatory	CE (EN61000-6-2 and EN61000-6-3), FCC part 15 class B, RoHS, WEEE	
Power	12V DC \pm 10%. <0.25A (Normal Operation)	
Lens mount	C-mount (Flange back 17.526 mm -0.05mm) Image centre \pm 0.1mm from C-mount centre	
Dimensions	44 x 29 x 66 mm (HxWxD)	
Weight	TBD 0g	

Note: Above specifications are subject to change without notice

11. Appendix

10.3. Precautions

Personnel not trained in dealing with similar electronic devices should not service this camera. The camera contains components sensitive to electrostatic discharge. The handling of these devices should follow the requirements of electrostatic sensitive components.

Do not attempt to disassemble this camera.

Do not expose this camera to rain or moisture.

Do not face this camera towards the sun, extreme bright light or light reflecting objects, including laser sources.

When this camera is not in use, put the supplied lens cap on the lens mount.

Handle this camera with the maximum care.

Operate this camera only from the type of power source indicated on the camera.

Remove power from the camera during any modification work, such as changes of jumper and switch settings.

10.4. Typical Sensor Characteristics

The following effects may be observed on the video monitor screen. They do not indicate any fault of the camera, but do associate with typical sensor characteristics.

V. Aliasing

When the camera captures stripes, straight lines or similar sharp patterns, jagged image on the monitor may appear.

Blemishes

All cameras are shipped without visible image sensor blemishes.

Over time some pixel defects can occur. This does not have a practical effect on the operation of the camera. These will show up as white spots (blemishes).

Exposure to cosmic rays can cause blemishes to appear on the image sensor. Please take care to avoid exposure to cosmic rays during transportation and storage. It is recommended using sea shipment instead of air flight in order to limit the influence of cosmic rays to camera.

Pixel defects/blemishes also may emerge due to prolonged operation at elevated ambient temperature, due to high gain setting or during long time exposure. It is therefore recommended to operate the camera within its specifications.

Patterned Noise

When the sensor captures a dark object at high temperature or is used for long time integration, fixed pattern noise may appear in the image.

Caution when mounting a lens on the camera

When mounting a lens on the camera dusts particles in the air may settle on the surface of the lens or the image sensor of the camera. It is therefore important to keep the protective caps on the lens and on the camera until the lens is mounted. Point the lens mount of the camera downward to prevent dust particles from landing on the optical surfaces of the camera. This work should be done in a dust free environment. Do not touch any of the optical surfaces of the camera or the lens.

Exportation

When exporting this product, please follow the export regulation of your own country.

10.5. References

1. This manual can for CM-140 MCL / CB-140 MCL can be downloaded from www.jai.com
2. Datasheet for CM-140 MCL / CB-140 MCL can be downloaded from www.jai.com
3. Camera control software can be downloaded from www.jai.com
4. Specifications for the CCD sensor Sony ICX-267AL and ICX-267AQ can be found on www.jai.com

11. User's Record

Camera type: CM-140 MCL / CB-140 MCL
Revision:
Serial No.
Firmware version.

For camera revision history, please contact your local JAI distributor.

User's Mode Settings.

User's Modifications.



DECLARATION OF CONFORMITY
AS DEFINED BY THE COUNCIL DIRECTIVE
89/336/EEC
EMC (ELECTROMAGNETIC COMPABILITY)
WE HEREWITH DECLARE THAT THIS PRODUCT
COMPLIES WITH THE FOLOWING PROVISIONS APPLYING TO IT.
EN61000-6-2
EN61000-6-3

Company and product names mentioned in this manual are trademarks or registered trademarks of their respective owners. JAI A-S cannot be held responsible for any technical or typographical errors and reserves the right to make changes to products and documentation without prior notification.

Europe, Middle East & Africa

*Phone +45 4457 8888
Fax +45 4491 8880*

Asia Pacific

*Phone +81 45 440 0154
Fax +81 45 440 0166*

Americas

*Phone (toll-free) +1 800 445 5444
Phone +1 408 383 0300*

Visit our web site at www.jai.com



See the possibilities