



*Digital Monochrome/Color
Progressive Scan GigE Vision Camera*

**CV-A10GE
CV-A70GE**

Operation Manual

Hardware part

Camera Revision: 0

Manual revision: 1.0

Table of Contents

1. General.....	3
2. Standard Composition	3
3. Main Features	4
4. Locations and Functions	5
5. Pin Assignment.....	6
5.1. 12-pin Multi-connector (DC-in/GPIO/Iris Video)	6
5.2. Digital Output Connector for Gigabit Ethernet.....	6
6. GPIO (Inputs and outputs)	7
6.1. Overview	7
6.1.1. LUT (Look Up Table)	7
6.1.2. 12-bit Counter	7
6.1.3. Pulse Generators	7
6.2. Inputs and outputs table	8
6.2.1. Equivalent circuit for TTL 1, 2 and 3 inputs	9
6.2.2. Equivalent circuit for LVDS input.....	9
6.2.4. Equivalent circuit for TTL 1 and 2 outputs.....	9
6.3. Configuring the GPIO module (register settings).....	10
6.3.1. Input/Output Signal Selector.....	10
6.3.2. xTTL_LVDS Selector.....	10
6.3.3. 12-bit counter	10
6.3.4. Pulse generators (20 bit x 4)	10
6.4 GPIO programming examples	12
6.4.1 Trigger Phase Control	12
6.4.3 Multi EEN Control with PWC.....	14
7. GigE Vision Streaming Protocol (GVSP)	15
7.1. Digital Video Output (Bit Allocation).....	15
7.2. Bit Allocation (Pixel Format / Pixel Type) - CV-A10GE.....	15
7.2.1. GVSP_PIX_MONO8 (8bit)	15
7.2.2. GVSP_PIX_MONO10 (10bit).....	15
7.3. Bit Allocation (Pixel Format / Pixel Type) - CV-A70GE.....	16
7.3.1 GVSP_PIX_BAYGB8 “BayerGB8” (For Full and 1/8 partial scanning).....	16
7.3.2 GVSP_PIX_BAYGB10 “ BayerGB10” (For Full and 1/8 partial scanning).....	16
7.3.3 GVSP_PIX_BAYRG8 “ BayerRG8 “ (For 1/2 and 1/4 partial scanning)	16
7.3.4 GVSP_PIX_BAYRG10 “Bayer RG10” (For 1/2 and 1/4 partial scanning).....	16
8. Functions and Operations	17
8.1. GigE Vision Standard Interface	17
8.2. Recommended Network Configurations	17
8.2.1 Verified Network Interface Cards (NICs)	17
8.2.2 Video data rate (network bandwidth)	17
8.3. Basic functions	18
8.3.1 Vertical Binning (CV-A10 GE only).	18
8.3.2 CV-A70 CL. Bayer filter	19
8.3.3 Electronic Shutter.....	19
8.3.4. ROI (Region of Interest)	20
8.3.5 Auto Iris Lens video output (12-pin Hirose connector).....	21
8.3.5 Auto Iris Lens video output (12-pin Hirose connector).....	21
8.4. Sensor Layout and timing	22
8.4.1. CCD Sensor Layout	22
8.4.2. Horizontal timing	23
8.4.3. Vertical timing	23
8.4.4. Partial Scanning.....	24
8.4.5. Vertical binning	24
8.5. Operation Modes	25
8.5.1. LVAL synchronous accumulation	26
8.5.2. LVAL a-synchronous accumulation	27
8.5.3. Continuous operation.....	28
8.5.4. Edge Pre-select Trigger Mode	29
8.5.5. Pulse Width Control Trigger Mode.....	30

CV-A10 GE / CV-A70 GE

8.5.6. Sequencer Trigger Mode (EPS)	31
8.5.7. Delayed Readout Mode (EPS, PWC)	32
8.6. Operation Mode and Functions matrix	33
9. Register Map	34
10. External Appearance and Dimensions	41
11. Specifications.....	41
11.1. Spectral response.....	41
11.2. Specification table	42
12. Appendix.....	43
12.1. Precautions	43
12.2. Typical Sensor Characteristics.....	43
12.3. References	44
Index.....	45
12. User's Record	1

1. General

This manual covers the digital monochrome progressive scan camera CV-A10 GE and color progressive scan camera CV-A70 GE

The CV-A10GE/CV-A70GE is a GigE Vision compliant camera, based on the CV-A10CL/CV-A70CL. Both the monochrome version CV-A10GE and the color version CV-A70GE provide a frame rate of 60 frames/second at full resolution. Using vertical binning (CV-A10GE only) and partial scan provides higher frame rates.

The 1/2" CCD with square pixels offers a superb image quality. The high-speed shutter function and asynchronous random trigger mode allows the camera to capture high quality images of fast moving objects.

The color version CV-A70 GE, based on CCD sensor with primary RGB Bayer mosaic filter, outputs raw Bayer images. Host-based color interpolation is required to display or save color images.

The CV-A10GE/CV-A70GE also complies with the GenICam standards, as it has in internal XML file that is used to describe the functions/features of the camera. For further information on GenICam please go to www.emva.org.

As an application programming interface, JAI provides an SDK (Software Development Kit). This SDK includes software documentation, register information, code examples and objects such as Transport Layer and Device Drivers (Optimized Filter Driver and Standard Windows Stack). The JAI SDK Light can be downloaded from www.jai.com

The latest version of this manual can be downloaded from www.jai.com

For camera revision history, please contact your local JAI distributor.

2. Standard Composition

The standard camera composition consists of the camera main body and C-mount protection cap.

The camera is available in the following versions:

CV-A10 GE - Monochrome progressive CCD scan camera.

CV-A70 GE - Raw Bayer color progressive CCD scan camera.

3. Main Features

- 1/2" progressive scan camera
- Monochrome and Bayer color versions
- 782 (h) x 582 (v) 8.37µm square pixels
- 60 fps with full resolution
- 250 fps with 1/8 partial scan
- Vertical binning (CV-A10GE) for higher frame rates and sensitivity
- High speed shutter from 1/60 to 1/300,000 second
- 8 or 10-bit output
- Edge pre-select, and pulse width trigger modes
- Auto shutter and smear-less mode
- Auto-Iris lens video output, auto shutter and AGC allow a wider light range
- Programmable GPIO module
- Comprehensive software suite and SDK (SDK Light) for Windows XP

4. Locations and Functions

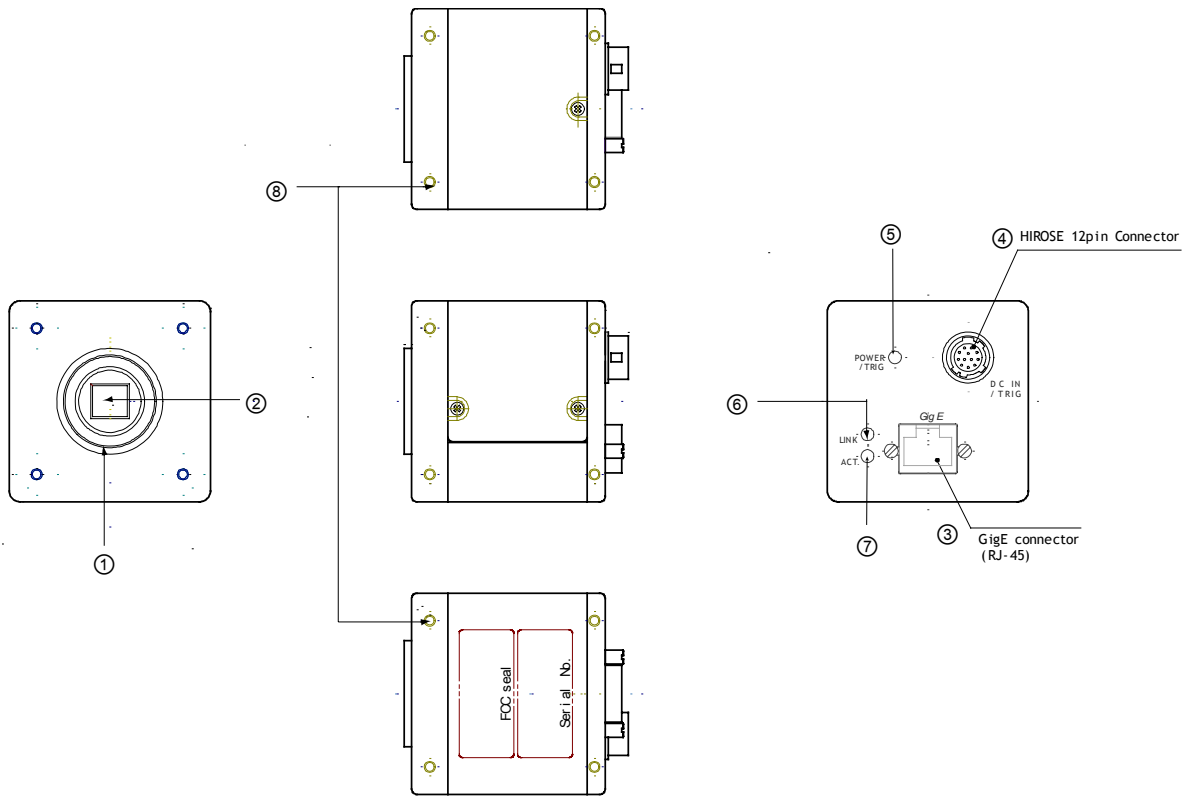

- 1 Lens mount of C-mount type. *1)
- 2 Interline-transfer CCD sensor.
- 3 GigE connector (RJ-45)
- 4 12-pin connector for DC +12V power and GPIO interface
- 5 LED for power and trigger indication
- 6 LED for GigE Network status : LINK
- 7 LED for GigE Network status : ACT.
- 8 Mounting holes 8 x M3 (depth 4 mm)

**1) Note: Rear protrusion on C-mount lens must be less than 9.0mm.
 When IR cut filter is used, it must be less than 6.0 mm.
 The IR cut filter is placed in the C-mount thread.
 The C-mount 25 mm IR cut filter must be ordered separately.*

Fig. 1. Locations

5. Pin Assignment

5.1. 12-pin Multi-connector (DC-in/GPIO/Iris Video)

Type: HR10A-10R-12PB

(Hirose) male.

(Seen from rear of camera.)

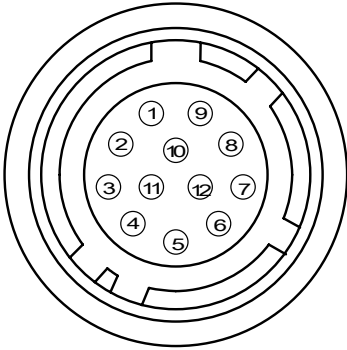

Pin no.	Signal	Remarks
1	GND	
2	+12 V DC input	
3	GND	
4	Iris video	Only Continuous mode.
5	GND	
6	LVDS+/TTL IN 1	GPIO IN / OUT
7	LVDS-/TTL IN 2	
8	TTL OUT 1	
9	TTL OUT 2	
10	TTL IN 3	
11	NC	
12	GND	

Fig. 2. 12-pin connector.

5.2. Digital Output Connector for Gigabit Ethernet

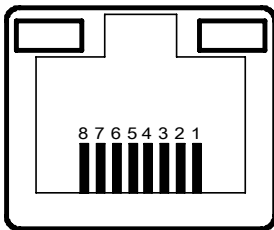

Type: RJ-45

Fig. 3. Gigabit Ethernet connector

The digital output signals follow the Gigabit Ethernet interface using RJ-45 conforming connector. The following is pin assignment for Gigabit Ethernet connector.

Pin No	In/Out	Name
1	In/Out	MX1+ (DA+)
2	In/Out	MX1- (DA-)
3	In/Out	MX2+ (DB+)
4	In/Out	MX3+ (DC+)
5	In/Out	MX3- (DC-)
6	In/Out	MX2- (DB-)
7	In/Out	MX4+ (DD+)
8	In/Out	MX4- (DD-)

6. GPIO (Inputs and outputs)

6.1. Overview

All input and output signals pass through the GPIO (General Purpose Input and Output) module. The GPIO module consists of a Look-Up Table (LUT - Cross-Point Switch), 4 Pulse Generators and a 12-bit counter. In the LUT, the relationship between inputs, counters and outputs is governed by internal register set-up.

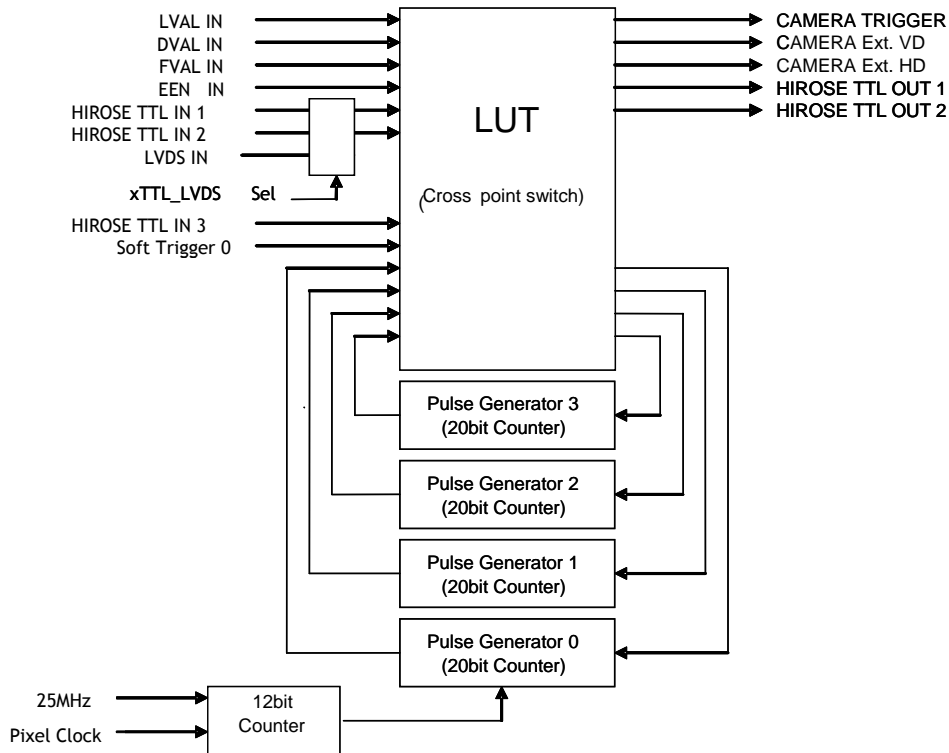

The blocks shown in the above diagram have the following functionality:

6.1.1. LUT (Look Up Table)

The LUT works as a cross-point switch which allows connecting inputs and outputs freely. The signals LVAL_IN, DVAL_IN, FVAL_IN and EEN_IN all originate from the camera timing circuit. The signal CAMERA_TRIGGER is connected to the camera timing circuit, allowing a hardware trigger. LUT works as a cross point switch which connects inputs and outputs freely.

6.1.2. 12-bit Counter

A 25MHz clock or the camera pixel clock can be used as a source. The counter has a “Divide by N”, where N has the range 1 through 4096, allowing a wide range of clock frequencies to be programmed.

6.1.3. Pulse Generators (0 to 3)

Each pulse generator consists of a 20-bit counter. The behavior of these signals is defined by their pulse width, start point, end point and number of repetitions.

The pulse generator signals can be set in either triggered or periodic mode.

In triggered mode, the pulse is triggered by the rising edge/falling edge/high level or low level of the input signal.

In periodic mode, the trigger continuously generates a signal that is based on the configured pulse width, starting point, end point and repetitions.

CV-A10 GE / CV-A70 GE

6.2. Inputs and outputs table

Signals	I/O	description	diagram
LVAL_IN	I	LVAL from camera	
DVAL_IN	I	DVAL from camera	
FVAL_IN	I	FVAL from camera	
EEN_IN	I	EEN from camera	
HIROSE_TTL_IN1	I	TTL-input from Hirose pin 6 Active when TTL is selected by xTTL_LVDS Sel	Fig. 4
HIROSE_TTL_IN2	I	TTL-input from Hirose pin 7 Active when TTL is selected by xTTL_LVDS Sel	Fig. 4
LVDS_IN	I	Hirose connector Pin 6: LVDS + Pin 7: LVDS - Active when LVDS is selected by xTTL_LVDS Sel	Fig. 5
HIROSE_TTL_IN3	I	TTL input signal from Hirose connector pin 10	Fig. 4
Soft_Trigger_0	I	Software trigger input from Ethernet	
Pulse Generator out 0	I	Pulse Generator 0 output	
Pulse Generator out 1	I	Pulse Generator 1 output	
Pulse Generator out 2	I	Pulse Generator 2 output	
Pulse Generator out 3	I	Pulse Generator 3 output	
CAMERA TRIGGER	O	Trigger signal to camera	
HIROSE TTL OUT 1	O	TTL output to Hirose connector pin 8	Fig. 6
HIROSE TTL OUT 2	O	TTL output to Hirose connector pin 9	Fig. 6
Pulse Generator in 0	O	Pulse Generator 0 Clear input	
Pulse Generator in 1	O	Pulse Generator 1 Clear input	
Pulse Generator in 2	O	Pulse Generator 2 Clear input	
Pulse Generator in 3	O	Pulse Generator 3 Clear input	

6.2.1. Equivalent circuit for TTL 1, 2 and 3 inputs

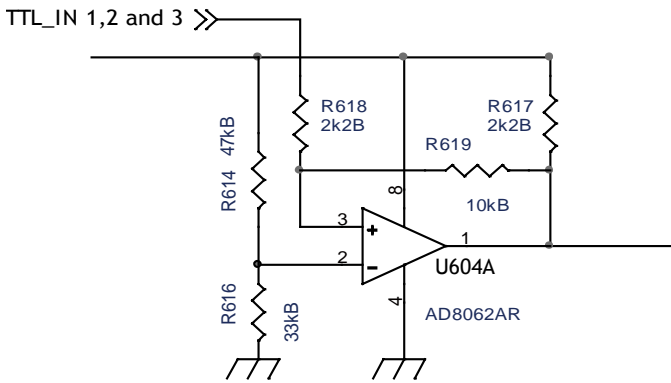

This circuit is for TTL IN 1, TTL IN 2 and TTL IN 3 through pins 6, 7 and 10 (respectively) at the 12-pin Hirose connector. It is a DC coupled input. See GPIO selector for setting this input (TTL or LVDS).

Fig.4 Hirose TTL IN (1 and 2) equivalent circuit

6.2.2. Equivalent circuit for LVDS input

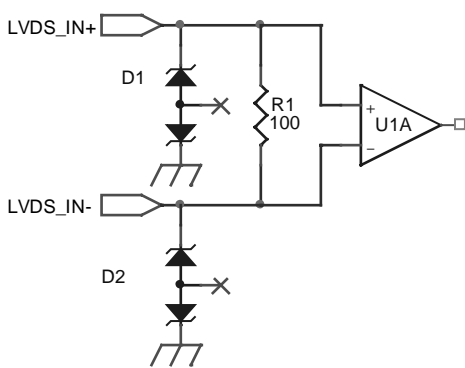

This circuit is for LVDS IN - and + through pins 6 and 7 the 12-pin Hirose connector. See GPIO selector for setting this input (TTL or LVDS).

Fig.5 LVDS IN equivalent circuit

6.2.4. Equivalent circuit for TTL 1 and 2 outputs

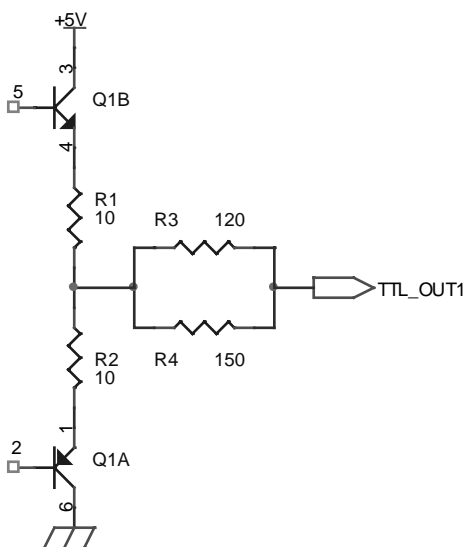

This circuit is for TTL OUT 1 and 2 through pins 8 and 9 of the Hirose 12-pin connector. The output is sent from 75 ohm source which is a complementary Emitter-follower circuit. The supply voltage for this circuit is 5V.

Fig.6 Hirose TTL OUT equivalent circuit

6.3. Configuring the GPIO module (register settings)

6.3.1. Input/Output Signal Selector

Address	Internal Name	Access	Size	Value (Range)
0xB058	CAMERA TRIGGER Selector	R/W	4	GPIO Selector: 0x00:CAMERA LVAL IN 0x01:CAMERA DVAL IN 0x02:CAMERA FVAL IN 0x03:CAMERA EEN IN 0x04:HIROSE TTL IN 1 0x05:HIROSE TTL IN 2 0x06:HIROSE TTL IN 3 0x07:HIROSE LVDS IN 0x09:SOFT TRIG 0 0x0D:Pulse Generator 0 0x0E:Pulse Generator 1 0x0F:Pulse Generator 2 0x10:Pulse Generator 3 0x7F:No Connect (default)
0xB05C	CAMERA Ex. VD Selector	R/W	4	
0xB060	CAMERA Ex. HD Selector	R/W	4	
0xB064	HIROSE TTL OUT 1 Selector	R/W	4	
0xB068	HIROSE TTL OUT 2 Selector	R/W	4	
0xB06C	Pulse Generator 0 Selector	R/W	4	
0xB070	Pulse Generator 1 Selector	R/W	4	
0xB074	Pulse Generator 2 Selector	R/W	4	
0xB078	Pulse Generator 3 Selector	R/W	4	

Add 0x80 will result in low active output.

6.3.2. xTTL_LVDS Selector

Address	Internal Name	Access	Size	Info or Assign
0xA8B0	xTTL_LVDS Select	R/W	4	0x00 : TTL In 1 and TTL In 2 Active 0x01 : LVDS In Active

6.3.3. 12-bit counter

Address	Internal Name	Access	Size	Value (Range)
0xB000	Clock source	R/W	4	0x00: 25MHz 0x01: Pixel Clock
0xB004	Divide by N	R/W	4	0x000: N=1 0x001: N=2 0x002: N=3 0xFFF: N=4096

6.3.4. Pulse generators (20 bit x 4)

There are 4 pulse generators (designated 0 through 3) that can be used to create various timing scenarios by programming start point, endpoint, length and repeats.

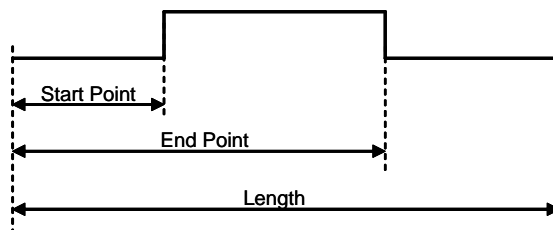

CV-A10 GE / CV-A70 GE

Address	Internal Name	Access	Size	Value (range)
0xB008	Length Counter 0	R/W	4	0x00001 to 0xFFFFF
0xB00C	Start point Counter 0	R/W	4	0x00000 to 0xFFFFF
0xB010	Repeat Count 0	R/W	4	0x00: infinite 0x01: 1 time 0xFF: 255 times
0xB014	End point Counter 0	R/W	4	0x00001 to 0xFFFFF
0xB018	Counter Clear 0	R/W	4	0: Free Run 1: High Level Clear 2: Low Level Clear 4: Rising Edge Clear 8: Falling Edge Clear
0xB01C	Length Counter 1	R/W	4	0x00001 to 0xFFFFF
0xB020	Start point Counter 1	R/W	4	0x00000 to 0xFFFFF
0xB024	Repeat Count 1	R/W	4	0: Infinite 1: 1 time 255: 255 times
0xB028	End point Counter 1	R/W	4	0x00001 to 0xFFFFF
0xB02C	Counter Clear 1	R/W	4	0x00: Free Run 0x01: High Level Clear 0x02: Low Level Clear 0x04: Rising Edge Clear 0x08: Falling Edge Clear
0xB030	Length Counter 2	R/W	4	0x00001 to 0xFFFFF
0xB034	Start point Counter 2	R/W	4	0x00000 to 0xFFFFF
0xB038	Repeat Count 2	R/W	4	0x00: Infinite 0x01: 1 time 0xFF: 255 times
0xB03C	End point Counter 2	R/W	4	0x00001 to 0xFFFFF
0xB040	Counter Clear 2	R/W	4	0x00: Free Run 0x01: High Level Clear 0x02: Low Level Clear 0x04: Rising Edge Clear 0x08: Falling Edge Clear
0xB044	Length Counter 3	R/W	4	0x00001 to 0xFFFFF
0xB048	Start point Counter 3	R/W	4	0x00000 to 0xFFFFF
0xB04C	Repeat Count 3	R/W	4	0x00: Infinite 0x01: 1 time 0xFF: 255 times
0xB050	End point Counter 3	R/W	4	0x00001 to 0xFFFFF
0xB054	Counter Clear 3	R/W	4	0x00: Free Run 0x01: High Level Clear 0x02: Low Level Clear 0x04: Rising Edge Clear 0x08: Falling Edge Clear

6.4 GPIO programming examples

6.4.1 Trigger Phase Control

100 clock delay to the input Trigger

Address	Register	Value
0xA040	Trigger Mode	1 = EPS(Edge pre-select)
0xB000	Clock Choice	1 = Pixel Clock
0xB004	Counter Dividing Value	0 = Pass through
0xB008	Length Counter 0	1000 Clocks
0xB00C	Start point Counter 0	100 Clocks
0xB010	Repeat Count 0	1
0xB014	End point Counter 0	500 Clocks
0xB018	Counter Clear 0	4 = Rising Edge Clear
0xB058	CAMERA TRIGGER Selector	13 = pulse generator 0
0xB06C	Pulse Generator 0 Selector	4 = HIROSE TTL In 1

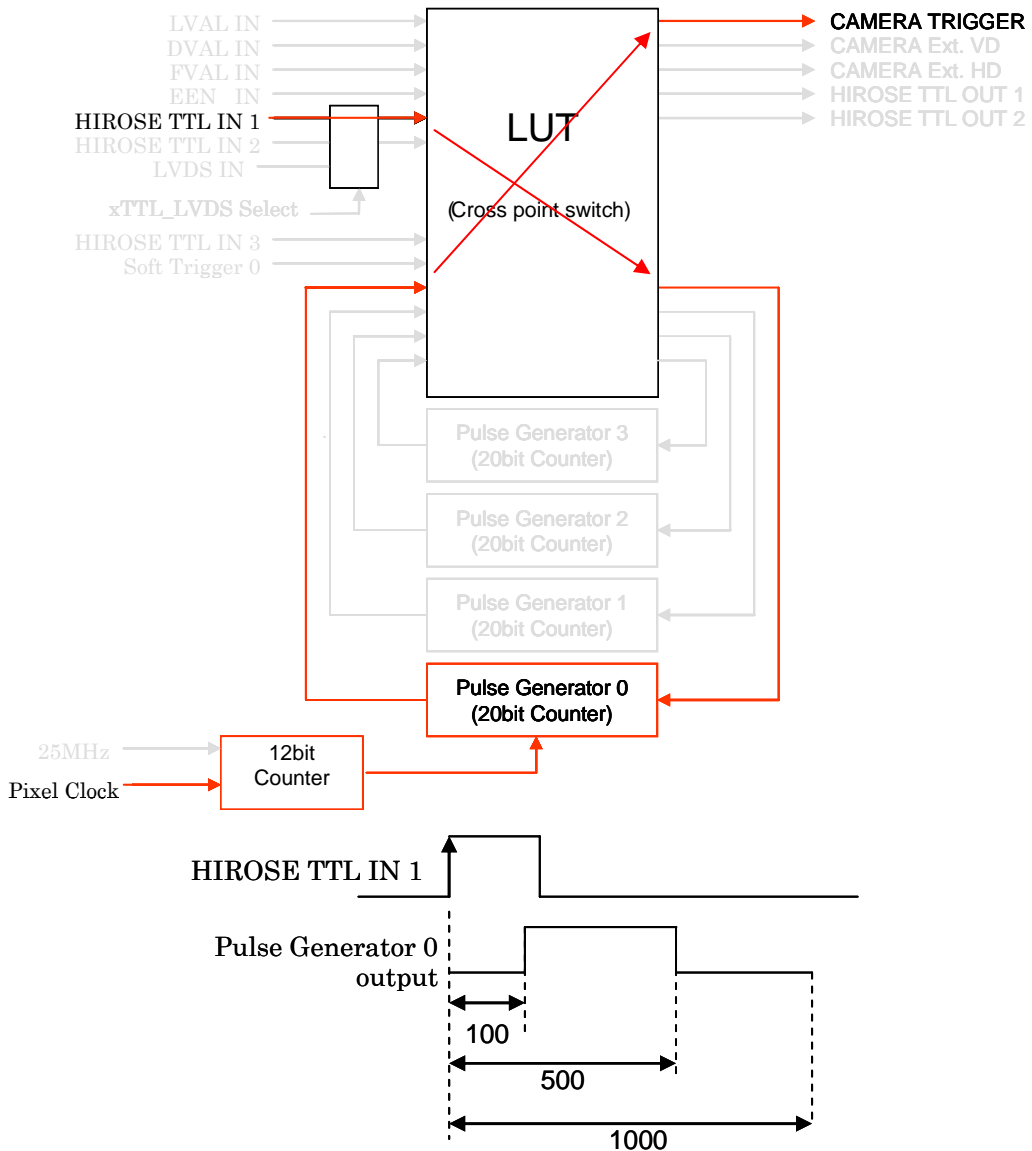

CV-A10 GE / CV-A70 GE

6.4.2 Internal Trigger Generator

Create a trigger signal and trigger the camera

Address	Register	Value
0xA040	Trigger Mode	1 = EPS
0xB000	Clock Choice	1 = Pixel Clock
0xB004	Counter Dividing Value	963 = 1/964 dev(Line Rate)
0xB008	Length Counter 0	1000 Clocks
0xB00C	Start point Counter 0	100 Clocks
0xB010	Repeat Count 0	0 = Free Run
0xB014	End point Counter 0	500 Clocks
0xB018	Counter Clear 0	0 = No Clear
0xB058	CAMERA TRIGGER Selector	13 = pulse generator 0

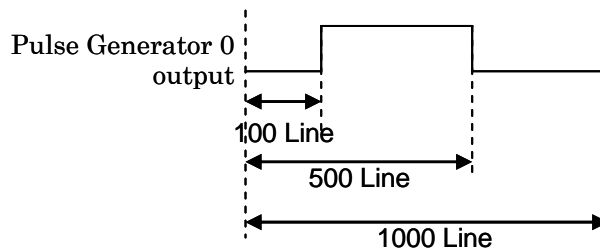
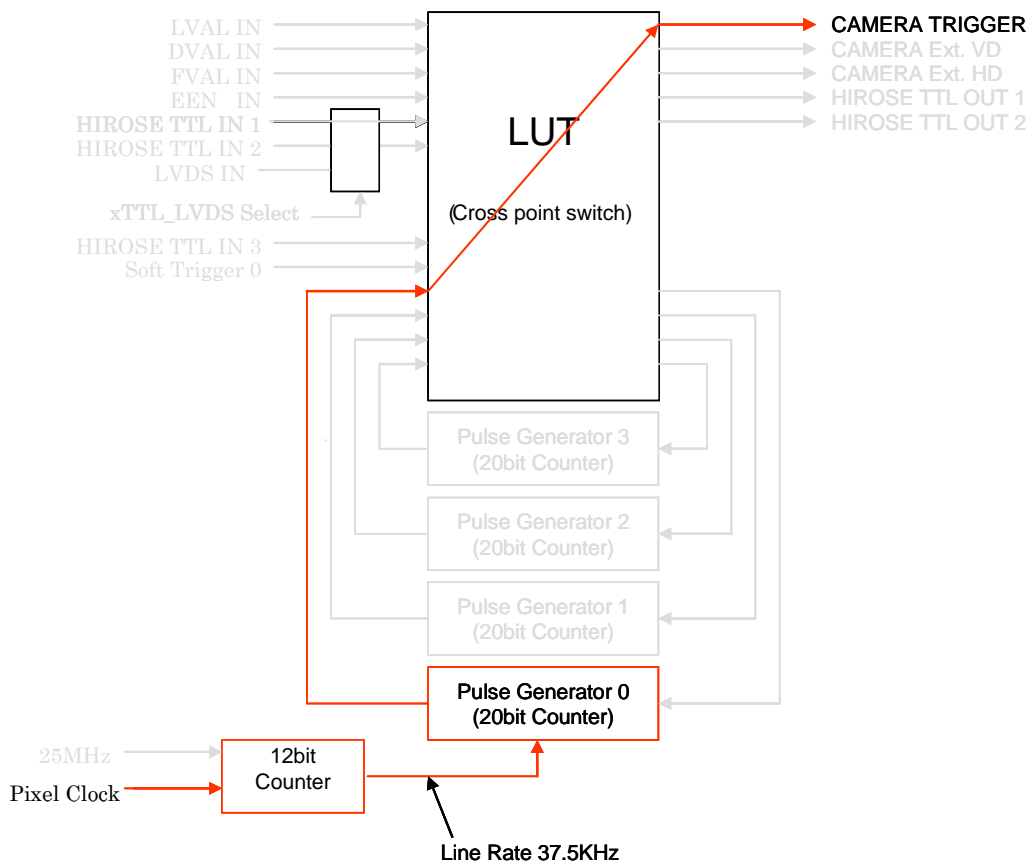

Pulse Generator 0 timing

CV-A10 GE / CV-A70 GE

6.4.3 Multi EEN Control with PWC

Camera EEN converts to 3 pulses and feed camera in PWC mode

Address	Register	Value
0xA040	Trigger Mode	2 = PWC(Pulse width control)
0xB000	Clock Choice	1 = Pixel Clock
0xB004	Counter Dividing Value	963 = 1/964dev(Line Rate)
0xB008	Length Counter 0	1000 Clocks
0xB00C	Start point Counter 0	100 Clocks
0xB010	Repeat Count 0	3 Cycles
0xB014	End point Counter 0	500 Clocks
0xB018	Counter Clear 0	1 = Level Low
0xB058	CAMERA TRIGGER Selector	4 = Hirose TTL IN 1
0xB06C	Pulse Generator 0 Selector	3 = CAMERA EEN IN

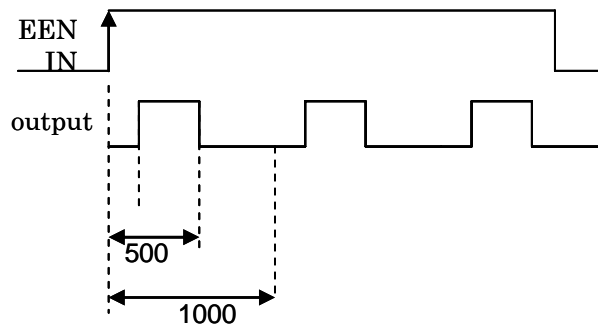
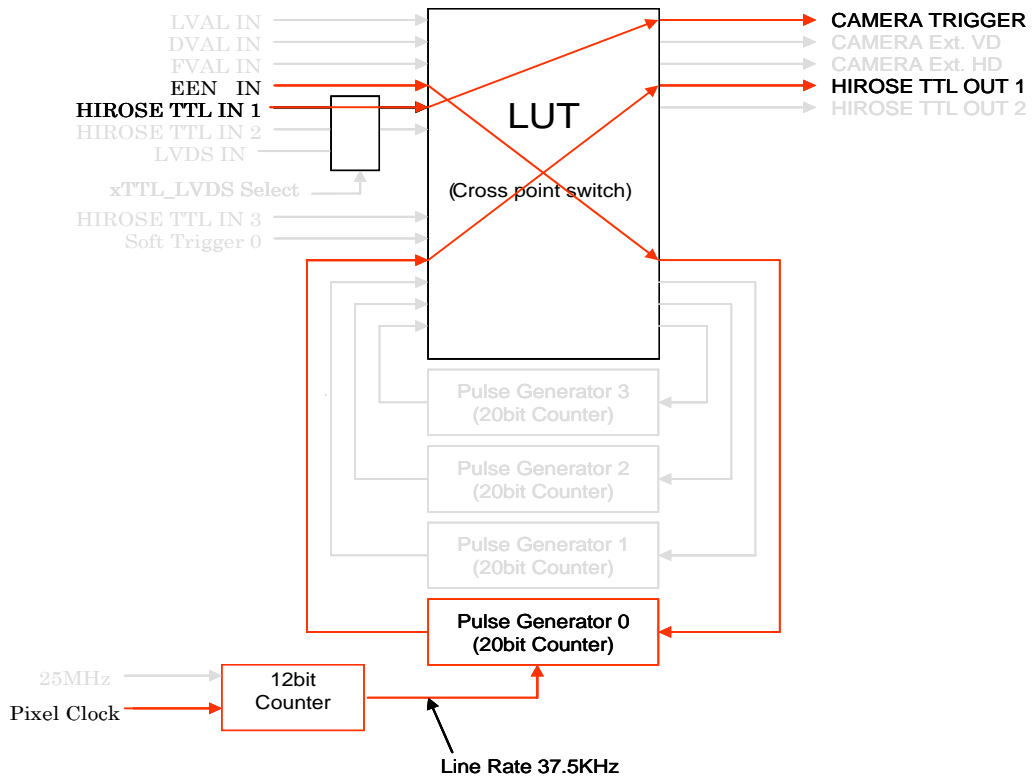

Pulse Generator 0 timing

7. GigE Vision Streaming Protocol (GVSP)

7.1. Digital Video Output (Bit Allocation)

Although the CV-A10GE and CV-A70GE are digital cameras, the image is generated by an analog component, the CCD sensor.

The table and diagram below show the relationship between the analog CCD output level and the digital output.

CCD out	Analog Signal *	Digital Out(8-bit)	Digital Out(10-bit)
Black	Setup 3.6%, 25mV	32LSB	8LSB
200mV	700mV	890LSB	222LSB
230mV	800mV	1023LSB	255LSB

The standard setting for 10-bit video level is 890 LSB. For 8-bit, the standard setting is 222 LSB. 200 mV CCD output level, 100% video output.

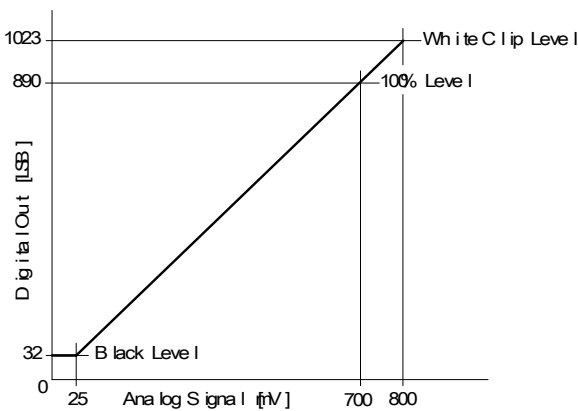

Fig.7. Analog to Digital conversion

7.2. Bit Allocation (Pixel Format / Pixel Type) - CV-A10GE

In the GigE Vision Interface, GVSP(GigE Vision Streaming Protocol) is used for an application layer protocol relying on the UDP transport layer protocol. It allows an application to receive image data, image information and other information from a device.

In CV-A10GE, the following pixel types supported by GVSP are available.

With regard to the details of GVSP, please refer GigE Vision Specification available from AIA (www.machinevisiononline.org).

7.2.1. GVSP_PIX_MONO8 (8bit)

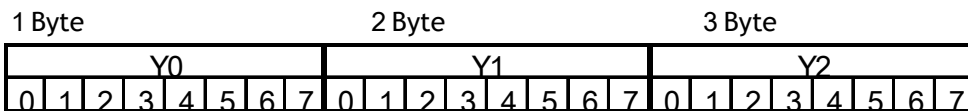

7.2.2. GVSP_PIX_MONO10 (10bit)

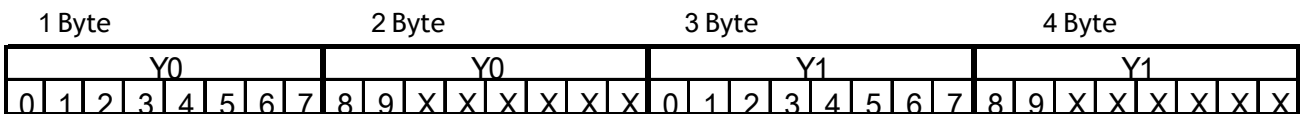

Address	Internal Name	Access	Size	Value
0xA410	Pixel Format type	R/W	4	0x01080001:Mono8 0x01100003:Mono10

CV-A10 GE / CV-A70 GE

7.3. Bit Allocation (Pixel Format / Pixel Type) - CV-A70GE

In the GigE Vision Interface, GVSP(GigE Vision Streaming Protocol) is used for an application layer protocol relying on the UDP transport layer protocol. It allows an application to receive image data, image information and other information from a device.

In CV-A70GE, the following pixel types supported by GVSP are available.

With regard to the details of GVSP, please refer GigE Vision Specification available from AIA.

7.3.1 GVSP_PIX_BAYGB8 "BayerGB8" (For Full and 1/8 partial scanning)

Odd Line

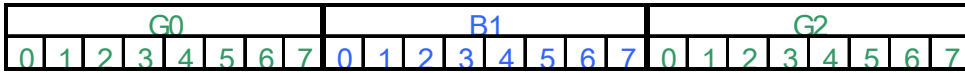

Even Line



7.3.2 GVSP_PIX_BAYGB10 "BayerGB10" (For Full and 1/8 partial scanning)

Odd Line

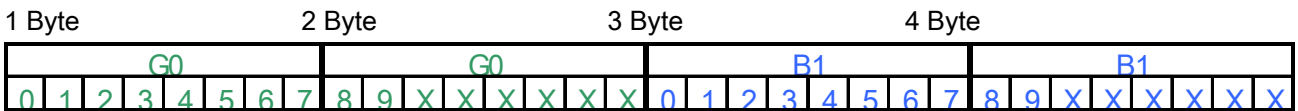

Even Line

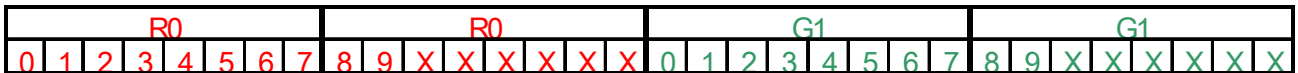

7.3.3 GVSP_PIX_BAYRG8 "BayerRG8" (For 1/2 and 1/4 partial scanning)

Odd Line

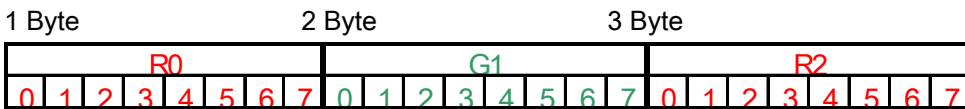

Even Line

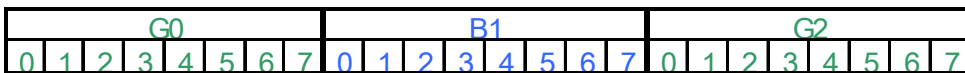

7.3.4 GVSP_PIX_BAYRG10 "Bayer RG10" (For 1/2 and 1/4 partial scanning)

Odd Line

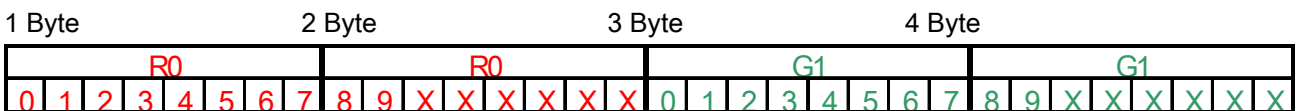

Even Line



Address	Internal Name	Access	Size	Value
0xA410	Pixel Format type	R/W	4	0x01080009: BAYRG8 0x0108000A: BAYGB8 0x0110000D: BAYRG10 0x0110000E: BAYGB10

8. Functions and Operations

8.1. GigE Vision Standard Interface

The CV-A10GE and CV-A70GE are designed in accordance with the GigE Vision standard. It transmits digital images over Cat5e or Cat6 Ethernet cables. All camera functions are also controlled via the GigE Vision interface.

The camera can operate in continuous mode, providing an endless stream of images. For capturing individual images, related to a specific event, the camera can also be triggered. For precise triggering, it is recommended to use a hardware trigger applied to the Hirose 12-pin connector. It is also possible to initiate a software trigger through the GigE Vision interface. However, when using software trigger, certain latency inherent to the GigE interface must be anticipated. This latency, that manifests itself as jitter, greatly depends on the general conditions and traffic on the GigE connection. The frame rate described in this manual is for the ideal case and may deteriorate depending on conditions.

When using multiple cameras (going through a switch and/or a single path) or when operating in a system with limited transmission bandwidth the Delayed Readout Mode and Inter-Packet Delay functions can be useful.

Details on how to use these functions are described in the SDK documentation.

8.2. Recommended Network Configurations

Although the CV-A10GE / CV-A70GE conforms to Gigabit Ethernet (IEEE 802.3) not all combinations of network interface cards (NICs) and Switches/Routers are suitable for use with the GigE Vision compliant camera.

JAI will endeavor to continuously verify these combinations, in order to give users the widest choice of GigE components for their system design.

8.2.1 Verified Network Interface Cards (NICs)

At the time of publishing this document these combinations have been verified:

NIC manufacturer	Model	PCI Bus	PCI-X Bus	PCI-Express Bus
Intel	PRO/1000MT (PWLA8490MT)	√ (33MHz)	√(100MHz)	–
Intel	PRO/1000GT (PWLA8391GT)	√ (33MHz)	√ (33MHz)	–
Intel	PRO/1000PT (EXPI9300PT)	–	–	√ (x1)

Minimum PC requirements are as follows in order to fulfill the above conditions:

IntelP4 2.8G (HT) or better, alternatively AMD Athlon 64 x2, CPU

At least 1 GB memory

More than 200 GB free disk space

Windows XP, SP2 (32bit)

Optimized filter driver included in the JAI SDK Light.

8.2.2 Video data rate (network bandwidth)

The video bit rate for CV-A10GE / CV-A70GE is:

8 bit pixel format (GVSP_PIX_MONO8/Bayer8)	212 M bit/s [767(H) x 576(V) x60(Frame) x 8(bit)]
10 bit pixel format (GVSP_PIX_MONO10/Bayer10)	265 M bit/s

CV-A10 GE / CV-A70 GE

[767(H) x 576(V) x60(Frame) x 10(bit)]

Note: However, as UPD Packet Header is added, the real bit rate will increase by 10%.

To ensure the integrity of packets transmitted from the camera is recommended to follow these simple guidelines:

1. Whenever possible use a peer-to-peer network.
2. When connecting several cameras, going through a network switch, make sure it is capable of handling jumbo packets and that it has sufficient memory capacity.
3. Configure inter-packet delay to avoid congestion in networks switches.
4. Disable screen saver and power save functions on computers.
5. Use high performance computers with multi-CPU, hyper-thread and 64-bit CPU, etc.
6. Only used Gigabit Ethernet equipment and components together with the camera.
7. Use at least Cat5e or preferably Cat6 Ethernet cables.
8. Whenever possible, limit the camera output to 8-bit.

8.3. Basic functions

The CV-A10GE / CV-A70GE camera is a progressive scan camera with 10 or 8 bit video output in Gigabit Ethernet. An analogue iris video signal can be used for lens iris control. The camera has 1/2, 1/4 or 1/8 partial scanning for faster frame rates. Vertical binning is also available.

The camera can operate in continuous mode as well as in 5 triggered modes:

- Edge pre-select(EPS)
- Pulse width control(PWC)
- Sequential trigger
- Delayed readout

The accumulation can be LVAL synchronous or LVAL a-synchronous. For trigger modes using fast shutter times, smear-less read out is possible.

In the following section the functions are described in detail.

8.3.1 Vertical Binning (CV-A10 GE only).

Vertical binning can be used to achieve higher frame rate and/or higher sensitivity. The drawback is reduced vertical resolution.

Vertical binning is done by adding the charge from pixels in adjacent lines in the horizontal CCD shift register.

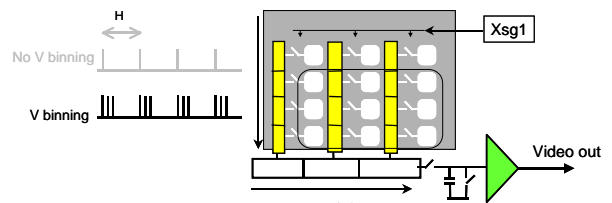

Fig. 8. CV-A10 GE binning principle.

The CV-A10GE has four settings for Vertical Binning:

Setting	Value for Register address 0xA084	Resolution	Frame rate
Off (no binning)	0x00	767(h) x 576(v) pixels	60 frames/sec.
2:1 binning	0x01	767(h) x 287(v) pixels	107 frames/sec.
3:1 binning	0x02	767(h) x 191(v) pixels	144 frames/sec.
4:1 binning	0x03	767(h) x 143(v) pixels	174 frames/sec.

8.3.2 CV-A70 CL. Bayer filter

CV-A70GE is a color camera based on a CCD sensor with a Bayer RGB color mosaic.

The color image reconstruction is done in the host PC.

The Color sequence in the video signal differs from full scanning to partial scanning. The right hand drawing shows the color sequence at the image start. The line readout follows LVAL.

The first valid pixel is delayed 8 pixels from LVAL. It is indicated by the rising edge of DVAL.

The Bayer color sequence starts with:
 GBG for even line numbers.
 RGR for odd line numbers.

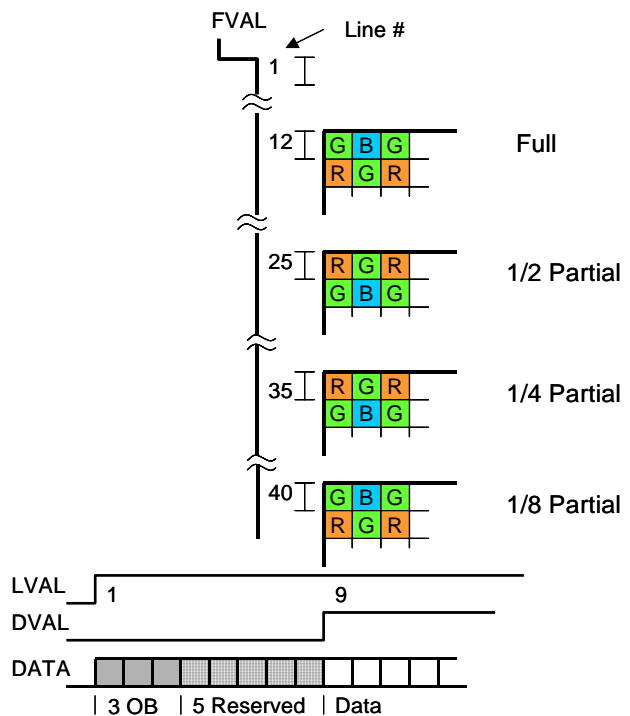

Fig. 9. CV-A70 GE Bayer RGB color sequence

8.3.3 Electronic Shutter

CV-A10GE / CV-A70GE has conventional shutter functions as well as the GenICam standard “Exposure Time Abs” function.

Preset Shutter

15 steps preset shutter are available: OFF (1/60); 1/100; 1/120; 1/250; 1/500; 1/1,000; 1/2,000; 1/4,000; 1/8,000; 1/15,000; 1/25,000; 1/75,000; 1/100,000; 1/150,000 and 1/300,000 sec. (See the register map included in the SDK documentation for details how to configure this register - 0xA004)

Programmable Exposure (PE)

It is possible to set the shutter speed in the range of 3.3 μ s to 16.7 ms for case of Full Frame operation. When 625L is set, it is the equivalent of “OFF (1/60)” or 16.7ms.

See the register map section in this document for details on how to configure this register - 0xA008)

Auto Shutter (CCD Shutter)

This function is available only in Continuous Mode.

The control range is OFF (1/60) to 1/25,000s.

Pulse Width Control

With this mode selected the exposure time is controlled by the width of the trigger pulse. The minimum trigger pulse width is equal to 2.5L (66.7 μ s).

The below table shows the possible exposure time range when using trigger modes

CV-A10 GE / CV-A70 GE

	Minimum Shutter Time	Maximum Shutter Time
Normal EPS	$13.3\mu\text{s}(0.5L)/4 = 3.3\mu\text{s}$ (equivalent to 1/300,000s)	1 Frame
PWC	$26.7\mu\text{s} \cdot 2L + 13.3\mu\text{s}(0.5L) = 66.7\mu\text{s}$ (equivalent to 1/15,000s)	120 Frames

Exposure Time Abs (GenICam Standard)

This is a function specified in the GenICam standard.

The shutter speed can be entered as an absolute exposure time in microseconds (μs) in register address 0xA054. The entered absolute time (Time Abs) is then converted to programmable exposure (PE) value inside the camera.

The step size $3.3\mu\text{s}$, $6.7\mu\text{s}$, $10\mu\text{s}$, $13\mu\text{s}$ for the first 4 steps and thereafter the step size is $26.7\mu\text{s}$.

The below table shows the relationship between the PE value used by the camera for the different readout modes and the value entered in register 0xA054:

PE value used by camera (0 to 628)	Full frame and Partial Scan readout (L=26.67)	2 line Vertical Binning readout (L=30.04). CV-A10GE only	3 line Vertical Binning readout (L=33.42) CV-A10GE only	4 line Vertical Binning readout (L=36.51) CV-A10GE only
0 (=3.3 μs)	$0\mu\text{s} < \text{Time Abs} < 6.6\mu\text{s}$	$0\mu\text{s} < \text{Time Abs} < 6.6\mu\text{s}$	$0\mu\text{s} < \text{Time Abs} < 6.6\mu\text{s}$	$0\mu\text{s} < \text{Time Abs} < 6.6\mu\text{s}$
1 (=6.7 μs)	$6.6\mu\text{s} \leq \text{T Abs} < 10\mu\text{s}$	$6.6\mu\text{s} \leq \text{T Abs} < 10\mu\text{s}$	$6.6\mu\text{s} \leq \text{T Abs} < 10\mu\text{s}$	$6.6\mu\text{s} \leq \text{Time Abs} < 10\mu\text{s}$
2 (=10.0 μs)	$10\mu\text{s} \leq \text{T Abs} < 13.3\mu\text{s}$	$10\mu\text{s} \leq \text{T Abs} < 13.3\mu\text{s}$	$10\mu\text{s} \leq \text{T Abs} < 13.3\mu\text{s}$	$10\mu\text{s} \leq \text{T Abs} < 13.3\mu\text{s}$
3 (=13.0 μs)	$13.3\mu\text{s} \leq \text{T Abs} < 39.6\mu\text{s}$	$13.3\mu\text{s} \leq \text{T Abs} < 43.0\mu\text{s}$	$13.3\mu\text{s} \leq \text{T Abs} < 46.4\mu\text{s}$	$13.3\mu\text{s} \leq \text{T Abs} < 49.5\mu\text{s}$
Integer of calc. ->	$((\text{Time Abs} - 13) / L) + 3$	$((\text{Time Abs} - 13) / L) + 3$	$((\text{Time Abs} - 13) / L) + 3$	$((\text{Time Abs} - 13) / L) + 3$

8.3.4. ROI (Region of Interest)

The CV-M9GE allows two ROIs to be set. The ROI must not be overlapping.

The below table shows the compatibility of trigger modes and ROI settings. Please note that "ROI 2" and "ROI 1 + ROI 2" is not a standard GenICam function.

To set ROI, use registers 0xA41C through 0xA43C.

Trigger Mode	ROI 1	ROI 2	ROI 1 + ROI 2
EPS Trigger	Yes	Yes	Yes
PWC Trigger	Yes	Yes	Yes
EPS Trigger Delayed Readout	Yes	No	No
PWC Trigger Delayed Readout	Yes	No	No

8.3.5 Auto Iris Lens video output (12-pin Hirose connector)

This analogue signal is not routed through the GPIO.

This signal is available at pin 4 of 12-pin Hirose connector. It can be used for lens iris control in Continuous mode only.

The signal is taken from the CCD sensor output before the gain circuit. The video output is without sync. The signal is 0.7 Vpp from <math><400 \Omega</math> AC coupled.

NOTE: It is not recommended to use auto shutter (CCD iris) in combination with an Auto Iris lens.

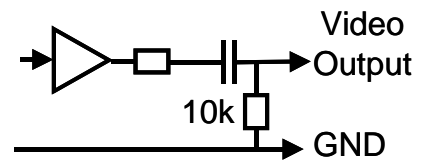

Fig. 11. Video output circuit.

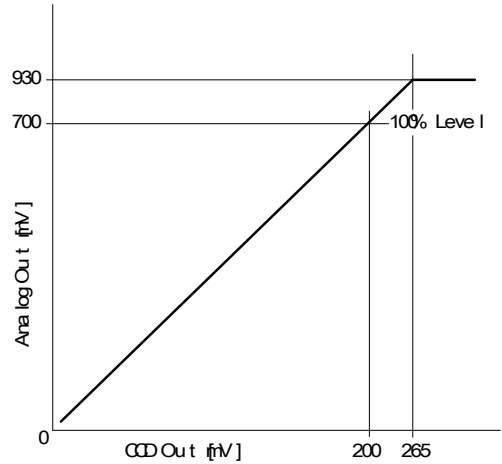

Fig. 12. Iris video output.

8.4. Sensor Layout and timing

8.4.1. CCD Sensor Layout

The CCD sensor layout with respect to pixels and lines used in the timing and video full frame read out is shown below.

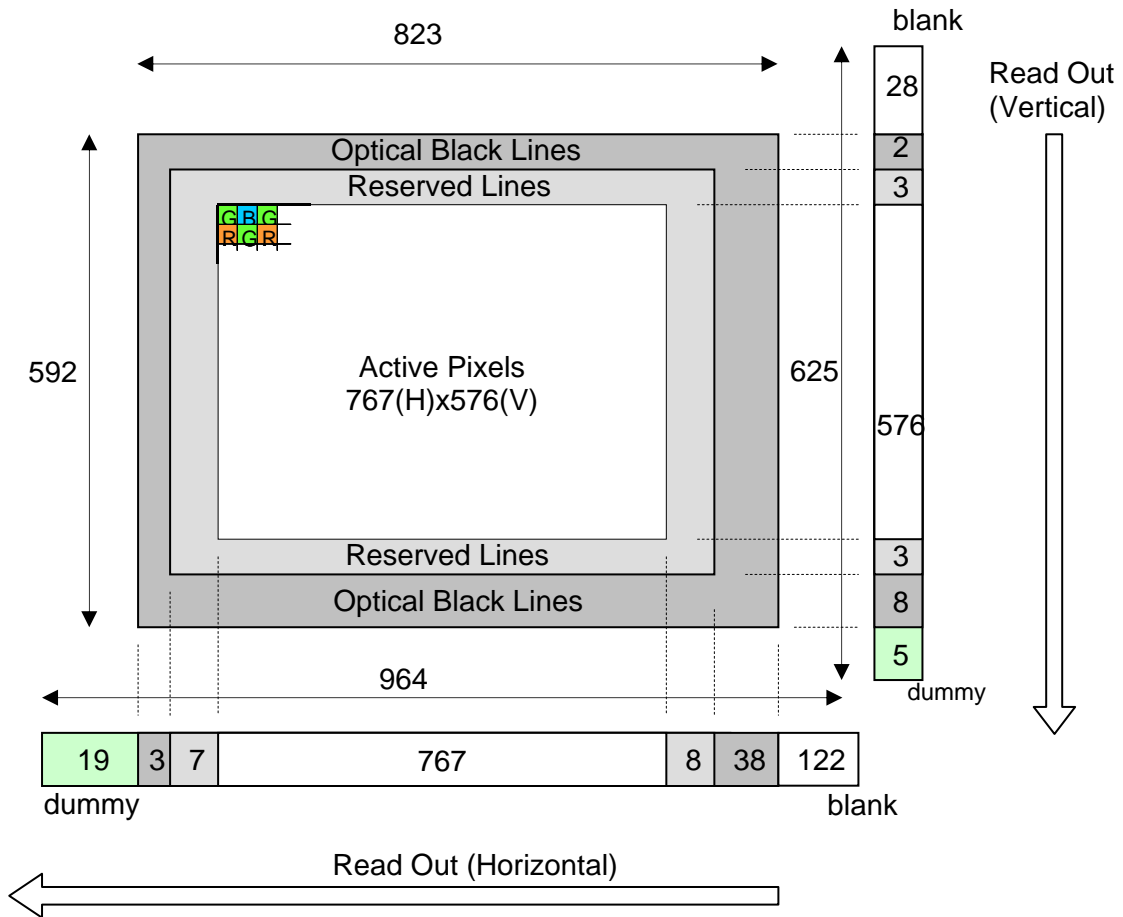

Fig. 12. CCD sensor layout

1 clock = 27.66 ns
1 line = 26.7 μs

Important Note: In GigE Vision, only Active Pixel Area is output through the GigE interface. Dummy, optical black and reserved areas are not output.

8.4.2. Horizontal timing

The LVAL period is shown for normal continuous mode.

1 clock = 27.66 ns

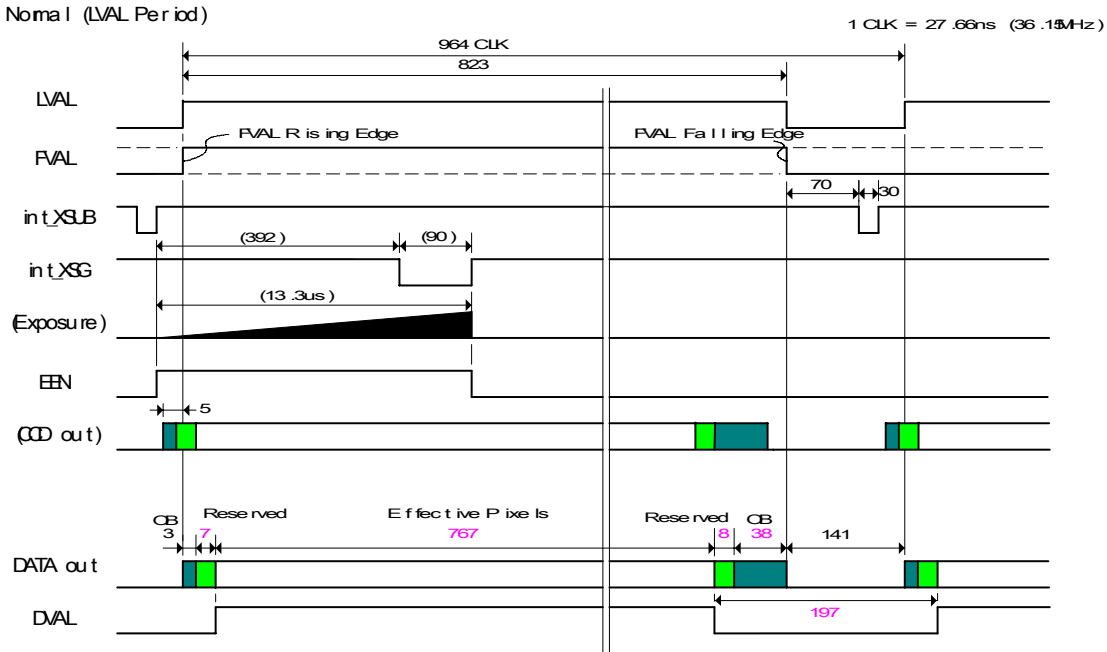

Fig. 13 Horizontal timing

8.4.3. Vertical timing

The FVAL period for normal continuous mode full scan is shown.

1 line = 26.7 μs

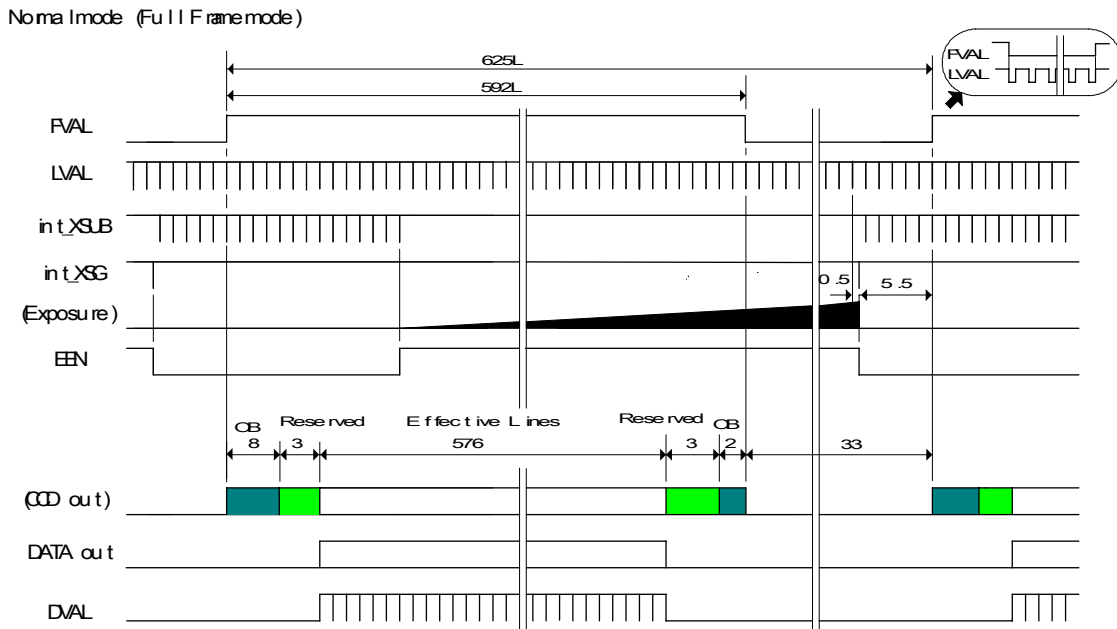

Fig. 14 Vertical timing for full scan

CV-A10 GE / CV-A70 GE

8.4.4. Partial Scanning

The FVAL period is shown for 1/2 partial scan in normal continuous mode.

1 line = 26.7 μs

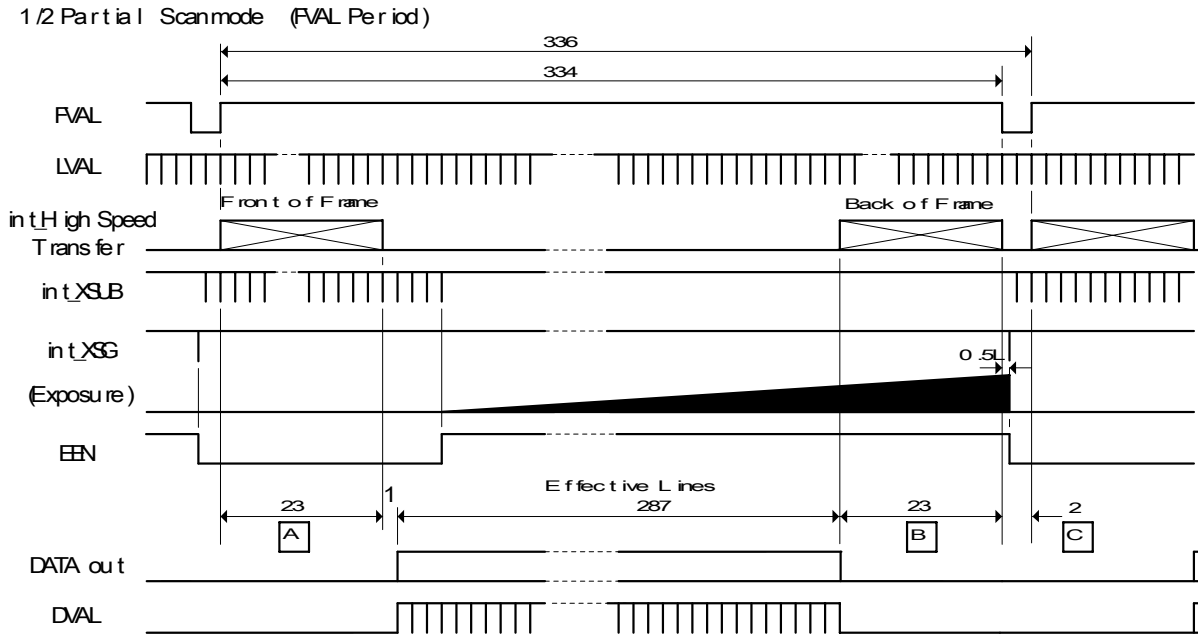

Values for vertical timing in partial scan continuous mode.

Scanning	Start line #	Stop line #	A Front [LVAL]	Effect. video [LVAL]	B Back [LVAL]	C Blank [LVAL]	Lines per frame	Frame Rate [FPS]	Remarks
Full	1	576	-	576	-	-	625	60	Full scan
1/2 partial	146	432	23	287	23	2	336	112	Vertically centered
1/4 partial	218	360	33	143	33	2	212	177	Vertically centered
1/8 partial	254	324	38	71	38	2	150	250	Vertically centered

Fig. 15 Vertical timing for partial scanning

8.4.5. Vertical binning

Values for the vertical timing with V binning in continuous mode.

Binning	Hor. freq. [KHz]	Effect. video [LVAL]	Lines per frame	Frame Rate [FPS]	Remarks
Off	37.50	576	625	60	
2:1 V binning	33.29	287	312	107	
3:1 V binning	29.92	191	208	144	
4:1 V binning	27.18	143	156	174	

Note: The vertical binning is available only for CV-A10GE.

8.5. Operation Modes

This camera can operate in 6 primary modes.

- | | |
|--|----------------------------------|
| 1. Continuous Mode | Pre-selected exposure. |
| 2. Edge Pre-select Mode (EPS) | Pre-selected exposure. |
| 3. Pulse Width Control Mode (PWC) | Pulse width controlled exposure. |
| 4. <i>Sequential Trigger</i> | Pre-selected exposure (EPS) |
| 5. <i>Delayed Readout Trigger</i> | Pre-selected exposure (EPS/PWC) |

The triggered accumulation in EPS, PWC, Sequential Trigger and Delayed Readout Trigger can be LVAL synchronous or LVAL a-synchronous.

In LVAL synchronous accumulation, a new exposure can be started while the previous frame is read out. The new exposure should not be finished before the frame is read out. FVAL (Trigger Duration) shall be low for >2 LVAL. The maximum frame rate in trigger modes can then be close to the frame rate in continuous mode.

The minimum trigger interval should be longer than $(1 \text{ FVAL} + 1 \text{ LVAL})$ in the case of Smear-Less OFF and Same RGB exposure time.

In LVAL a-synchronous accumulation, a new trigger must not be applied before the previous frame is read out. (FVAL is low).

The minimum trigger interval should be longer than $(\text{exposure time} + 1 \text{ FVAL} + 1 \text{ LVAL})$.

Refer to chapter 8.5.1. and 8.5.2. for accumulation details.

8.5.1. LVAL synchronous accumulation

In LVAL accumulation mode, the accumulation will start synchronously with LVAL. The trigger pulse must be longer than 2 LVAL periods. Accumulation will start at the first LVAL after the trigger leading edge. The exposure start delay will be up to 1 line (26.7 μsec.).

In EPS mode the exposure stops 0.5 L after the selected shutter time, (in number of LVAL).

In PWC mode the exposure stops 0.5 L after the first LVAL after the trigger trailing edge. It results in up to 1 LVAL jitter.

When triggering the camera with LVAL synchronous accumulation activated, a new exposure can be started while the previous frame is being read out. The new exposure should not finish before the frame is read out.

Minimum trigger interval $\geq (1 FVAL(625L) + 3 LVAL)$. (EPS/PWC mode)

Edge Pre-Select Mode : Full Frame

Edge Pre-Select mode の例 (Full Frame)

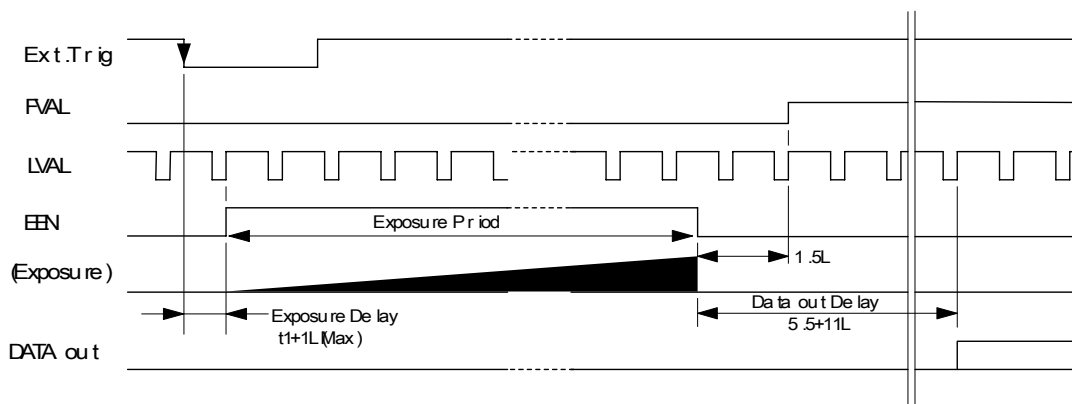

Fig. 16 LVAL synchronous accumulation in EPS mode

Pulse Width Control Mode : Full Frame

Pulse Width Control mode の例 (Full Frame)

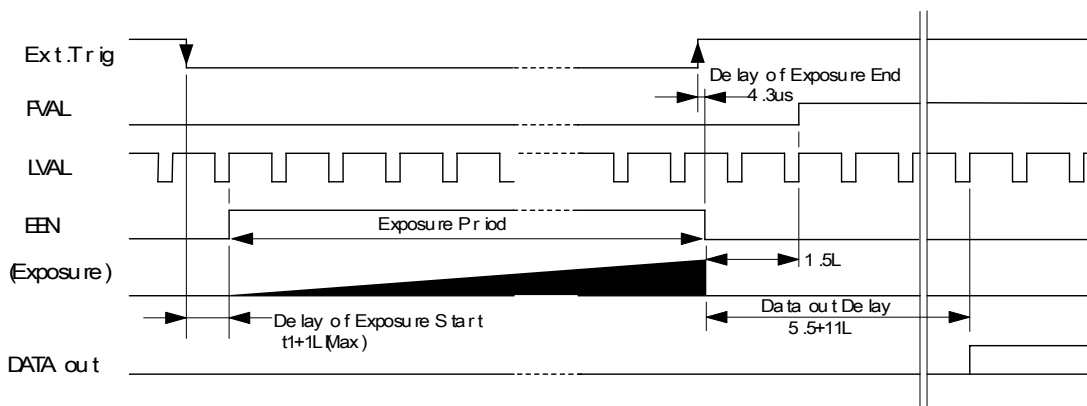

Fig. 17. LVAL synchronous accumulation in PWC mode

8.5.2. LVAL a-synchronous accumulation

On LVAL a-synchronous mode, the accumulation will start immediately after the trigger leading edge. The exposure start delay is t_1 .

In EPS mode the exposure stops 0.5 L after the selected shutter time, (in number of LVAL).

In PWC mode the exposure stops 0.5L after the trigger trailing edge.

A new trigger must not be applied before the previous frame is read out. (FVAL is low).

Minimum trigger interval \geq (exposure time + 1 FVAL (625L) + 2 LVAL). (EPS/PWC mode)

Edge Pre-select Mode : Full Frame

Edge Pre Select mode の例 (Full Frame)

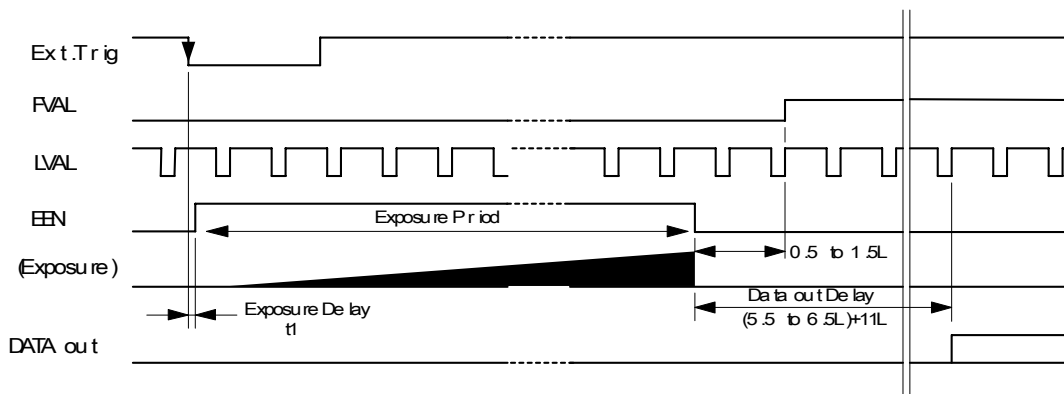

Fig. 19. LVAL a-synchronous accumulation in EPS mode

Pulse Width Control Mode: Full Frame

Pulse Width Control mode の例 (Full Frame)

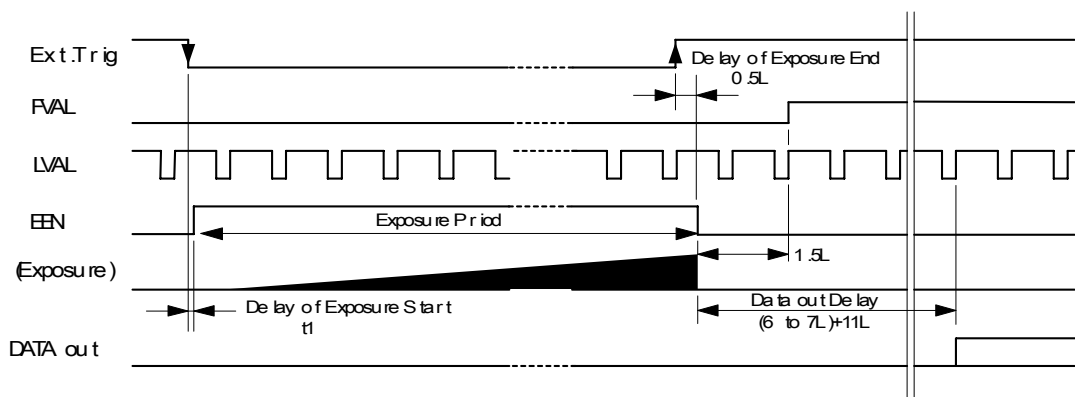

Fig. 19. LVAL a-synchronous accumulation in PWC mode

8.5.3. Continuous operation

For applications not requiring asynchronous external trigger, but where a continuous stream of images is required, this mode should be used.

This mode permits the use of a lens with video controlled iris.

For timing details, refer to fig. 15. through fig. 21.

To use this mode:

Set function:	Trigger mode	Continuous
	Scanning	Full, Partial scanning
	Vertical binning	On/Off (CV-A10GE only)
	Shutter mode	Preset, Programmable, Auto
	Exposure time	

8.5.4. Edge Pre-select Trigger Mode

An external trigger pulse initiates the capture, and the exposure time (accumulation time) is the fixed shutter speed set by registers. The accumulation can be LVAL synchronous or LVAL a-synchronous.

The resulting video signal will start to be read out after the selected shutter time.

For timing details, refer to fig. 15. through fig. 21. and fig. 26.

To use this mode:

Set function:	Trigger mode	EPS
	Scanning	Full, Partial
	Vertical binning	ON / OFF
	Shutter mode	Preset, Programmable
	Shutter speed	
	Programmable exposure	
	Accumulation	LVAL Sync / LVAL a-sync
	Other functions and settings	
Input:	Ext. trigger.	GigE interface or 12-pin Hirose

Important notes on using this mode

- Trigger pulse >1 LVAL to <1 FVAL
- Minimum trigger interval in synchronous accumulation mode $\geq (1 \text{ FVAL}(625\text{L}) + 1 \text{ LVAL})$
- Minimum trigger interval with Sequential Mode together = n/a lines

Edge Pre Select mode (FVAL Period, Asynchronous mode)

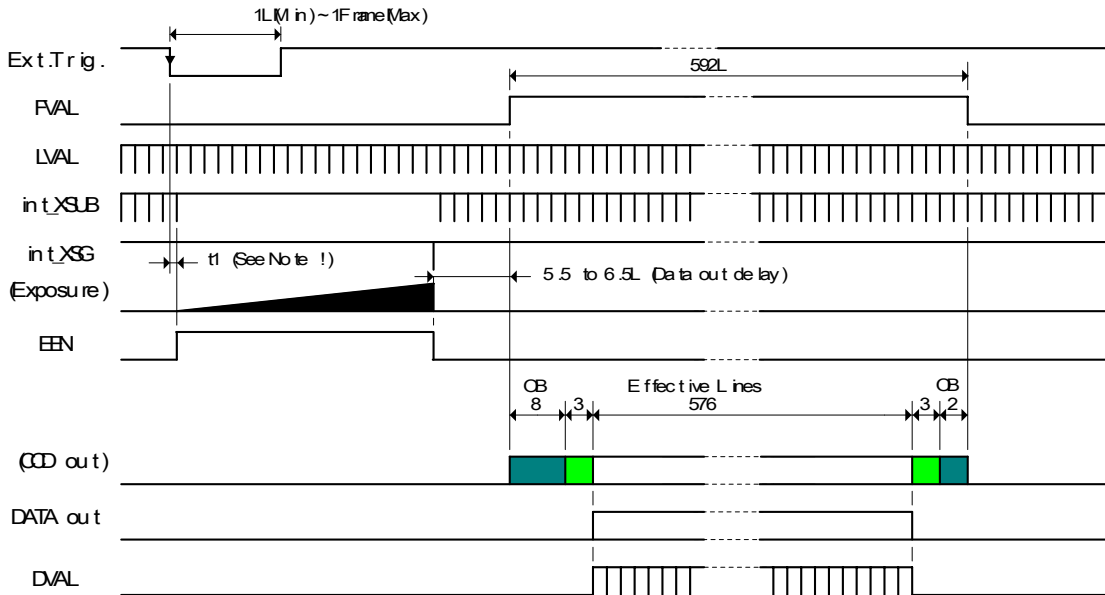

Exposure Time	Delayed of Exposure start
$\leq 1/25,000\text{s}$	4us
$1/75,000\text{s}$	4us
$1/100,000\text{s}$	7us
$1/150,000\text{s}$	11us
$1/300,000\text{s}$	14us

Fig. 20. Edge Pre-select Timing

8.5.5. Pulse Width Control Trigger Mode

In this mode the accumulation time is equal the trigger pulse width. Here it is possible to have long time exposure. The maximum recommended time is <2 seconds.

The accumulation can be LVAL synchronous or LVAL a-synchronous.

The resulting video signal will start to be read out after the trigger rising edge.

For timing details, refer to fig. 15. through fig. 21. and fig. 27.

To use this mode:

Set function:	Trigger mode	PWC
	Scanning	Full , Partial
	Vertical binning	ON / OFF
	Accumulation	LVAL sync / LVAL a-sync
	Other functions and settings	
Input:	Ext. trigger.	GigE interface or 12-pin Hirose

Important notes on using this mode

- Trigger pulse width >2 LVAL to <2 seconds
- Minimum trigger interval in synchronous accumulation mode
 $\geq (1 \text{ FVAL}(625\text{L}) + 3 \text{ LVAL})$

If the trigger width is longer than 1 frame, the exposure time will be added to the above equation.

- Minimum trigger interval in a-synchronous accumulation mode
 $\geq (\text{exposure time} + 1 \text{ FVAL}(625\text{L}) + 2 \text{ LVAL}).$
- When using the PWC in combination with the Smear-less function, the actual exposure time is: Trigger duration - Smear-less time (86L).

Pulse Width Control mode (FVAL Period, Asynchronous mode)

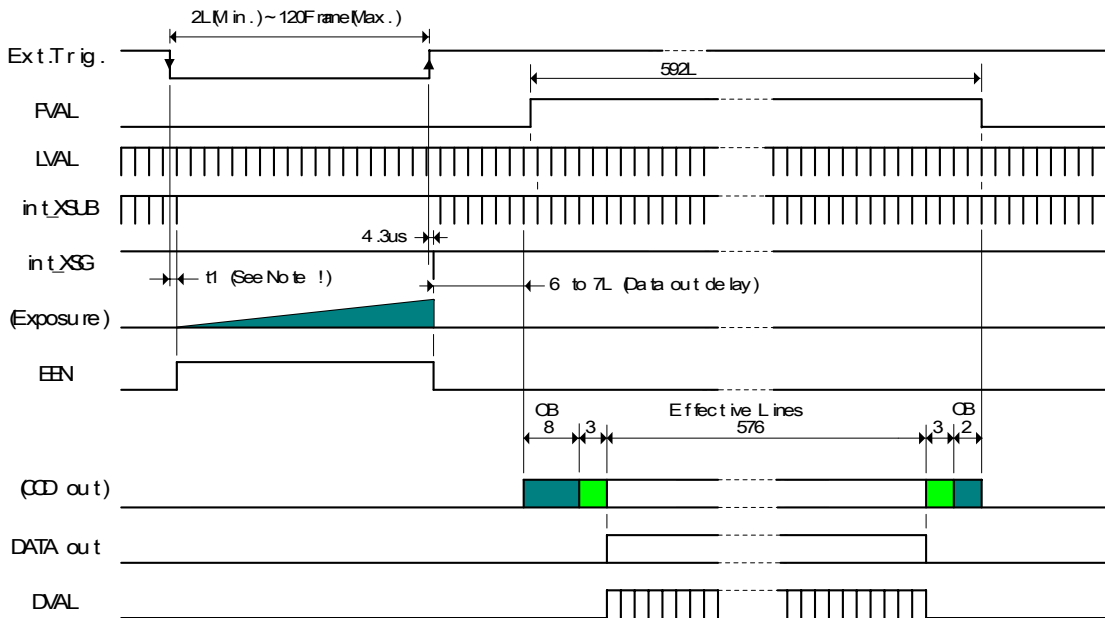
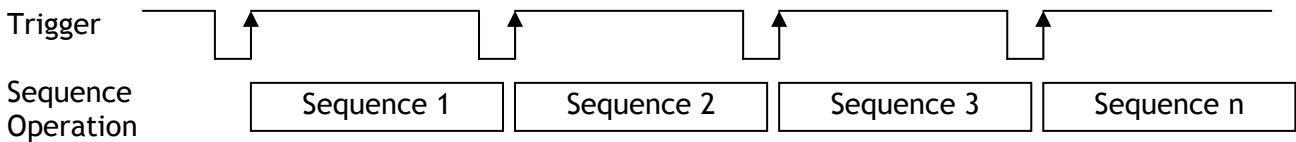

Fig. 22. Pulse width control. LVAL a-synchronized.

8.5.6. Sequencer Trigger Mode (EPS)

Shutter and Gain values can be preset for a sequence of up to 10 steps. Along with every trigger input, the image data with the preset sequence is output as described below.

In this mode, the minimum trigger interval is 1690 lines.



The trigger source can be selected by setting the Camera Trigger Selector in the GPIO (register 0xB058). The trigger pulse reacts on the leading edge. Negative or positive logic can be selected.

The default values for Gain and Shutter (Exposure) settings are shown in the register map.

The following registers are used to configure the sequence.

0xA800	Number of Repetitions
0xA804	Ending Position
0xA3F0	Sequence Reset
0xB058	Trigger source input, TTL1, 2 and 3 on the 12-pin Hirose connector as well as soft trigger
0xA040	Trigger mode selection (except Continuous and PWC)

Example of settings

Setting : Repeat 5 times from ID 1 through ID 8

0xA800	Set to 0x05
0xA804	Set to 0x08
0xB058	e.g. 0x06, trigger input at Pin 10 (TTL 3) on the 12-pin Hirose connector
0xA040	Set to 0x09 for Sequential EPS
0xA3F0	Set this register to 0x01 for start
0xA040	Set to Continuous Mode (0x00) to stop

To create an endless loop (infinite repetitions) set 0xA800 to 0x00.

Further details are available in the Register Map section of this manual.

8.5.7. Delayed Readout Mode (EPS, PWC)

This mode can be used to delay the transmission of a captured image. When several cameras are triggered simultaneously and connected to the same GigE interface, it allows the cameras to be read out in sequence, preventing congestion.

The image data is not transmitted directly by the trigger and it is stored in the memory located at Ethernet Interface. By the falling edge of the soft trigger 1, the image data is output.

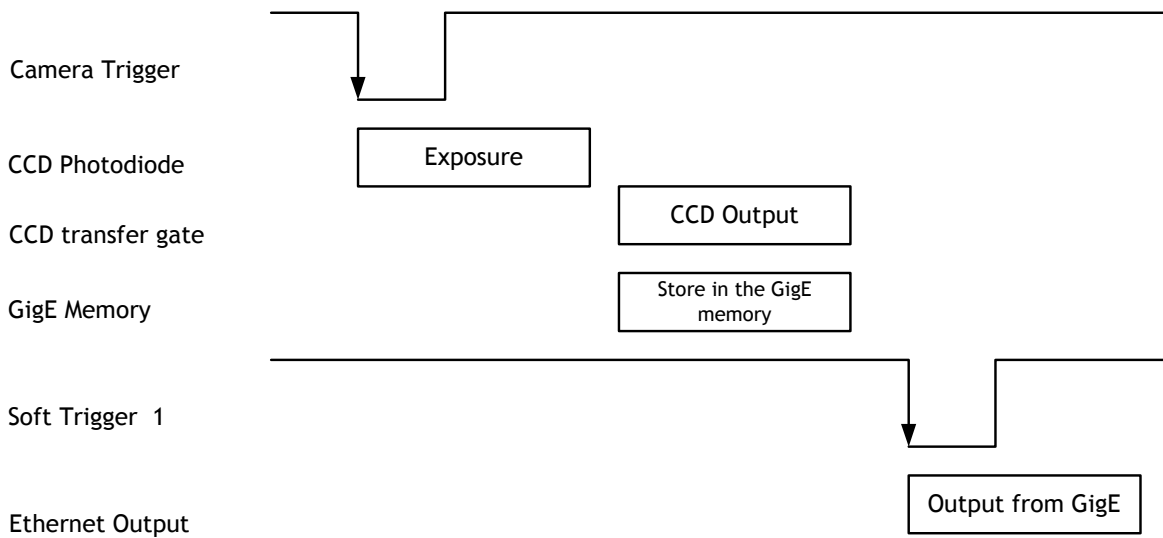

Example of settings

0xA040 EPS Delayed Readout (0x11) or PWC Delayed Readout (0x12)
0xA418 Soft Trigger 1 (30 bit)

Further details are available in the Register Map section of this manual.

8.6. Operation Mode and Functions matrix

ID (Value) Note 1	Mode	Shutter Preset / Program.	Binning	Partial Scanning	Smear-less	LVAL Sync/Async	Auto Iris output
0x00	Continuous	Yes	Yes	Yes	No	---	Yes Note 2
0x01	Edge Pre-select (EPS)	Yes	Yes	Yes	Yes	Yes	No
0x02	Pulse Width Control (PWC)	Not applicable	Yes	Yes	Yes	Yes Note 3, 4	No
0x09	Sequencer Edge Pre-select (EPS)	Yes	Yes	Yes	Yes	Yes	No
0x11	EPS Delayed Readout	Yes	Yes	Yes	Yes	Yes	No
0x12	PWC Delayed Readout	Not applicable	Yes	Yes	Yes	Yes Note 3, 4	No

Note 1: Write ID (Value) in register address 0xA040 in order to set trigger mode.

Note 2: In partial scan mode Auto Iris output is available, but Auto Exposure is not available.

Note 3: When using trigger modes in combination with Smear-less readout, only LVAL-synchronous accumulation is active.

Note 4: In PWC trigger mode, do not use LVAL a-synchronous accumulation if the trigger pulse has a pulse width exceeding 3 frames.

9. Register Map

The below table provides detailed information for the hardware registers used for controlling the camera and obtaining information on the status of the camera.

The content of this register map is also found in the XML file, as stipulated by the GenICam standard.

Generic Registers:

Address	Function	Read / Write	Size	Value / Range of value	Description	Default value
0x0000	Version	R	4	(Major, Minor) vector	Version of the GigE Standard to which the device is compliant.	
0x0004	Device mode	R	4		Information about device mode of operation.	
0x0008	Device MAC address (high)	R	4		Upper 4 bytes of the MAC address	
0x000c	Device MAC address (low)	R	4		Lower 4 bytes of the MAC address	
0x0010	IP	R	4	Bit 0: persistent Bit 1: DHCP Bit 2: LLA	Bits can be OR-ed. All other bits are reserved and set to 0. DHCP and LLA bits must be on.	
0x0014	IP address setup	R/W	4	Bit 0: persistent Bit 1: DHCP Bit 2: LLA	Bits can be OR-ed. LLA is always activated and is read only.	
0x0024	Current IP address	R	4			
0x0034	Current subnet mask	R	4			
0x0044	Current default gateway	R	4			
0x0048	Manufacturer's name	R	32		e.g. JAI	
0x0068	Model name	R	32		e.g. CV-A10GE	
0x0088	Device version	R	32			
0x00A8	Manufacturer specific info	R	80		Provides extended manufacturer information about the device.	
0x00D8	Serial number	R	16		Camera serial number	
0x00E8	Camera ID	R/W	16		User assignable string	
0x0200	First choice of URL for XML device description file	R	512		File extension .XML indicates uncompressed text file. File extension .ZIP indicates compressed using ZIP.	
0x0400	Second choice of URL for XML	R	512			
0x0600	Number of network interfaces	R	4		Indicates the number of physical network interfaces on this device.	
0x064C	persistent IP address	R/W	4		Valid if Persistent IP is enabled	
0x065C	persistent subnet mask	R/W	4		Valid if Persistent IP is enabled	
0x066C	persistent gateway	R/W	4		Valid if Persistent IP is enabled	

CV-A10 GE / CV-A70 GE

0x0900	number of messaging channels	R	4	This camera has 1	number of available message channel	
0x0904	number of stream channels	R	4	This camera only has 1	number of available stream channel	
0x0934	GVCP capability	R	4	Bit 31:multiple read Bit 30:WRITEMEM Bit 29:ACKETRESEND Bit 28:EVENT Bit 27:EVENTDATA	This is a capability register indicating which one of the non-mandatory GVCP commands are supported by this device.	
0x0938	Heartbeat timeout	R/W	4	The min. value is 500 ms	In milliseconds. Internally, the heartbeat is rounded according to the clock used for heartbeat.	3000 msec
0x093C	Timestamp tick frequency (High)	R	4	Timestamp tick frequency is 0 if timestamp is not supported.	64-bit value indicating the number of timestamp clock ticks in 1 second. This register holds the most significant bytes.	
0x0940	Timestamp tick frequency (Low)	R	4		This register holds the least significant bytes.	
0x0944	Timestamp control	W	4	Bit 0: Reset Bit 1:latch current timestamp	Used to latch the current timestamp value. No need to clear to 0.	
0x0948	Timestamp (High)	R	4		Latched value of the timestamp (most significant bytes)	
0x094C	Timestamp (Low)	R	4		Latched value of the timestamp (least significant bytes)	
0x0a00	CCP	R	4		control channel privilege register	
0x0b00	MCP	R/W	4		message channel port register	0
0x0b10	MCDA	R/W	4	Set by application	message channel destination address register	
0x0b14	MCTT	R/W	4		message channel transfer timeout: ms	300
0x0b18	MCRC	R/W	4		message channel retry count	2
0x0d00	SCP0	R/W	4	Not specified	primary stream port register	
0x0d04	SCPS0	R/W	4	Set by application	primary stream channel packet size register packet size includes IP, UDP&GVSP Header	1440
0x0d08	SCP0D	R/W	4	Max. 2 ms	primary stream channel packet delay register	64
0x0d18	SCDA0	R/W	4	Set by application	primary stream channel destination address register	

CV-A10 GE / CV-A70 GE

Standard camera functions registers:

Address	Function	Read / Write	Size	Value / Range of value	Description	Default value
0xA000	Shutter mode	R/W	4	0= Preset shutter 1= Programmable exposure 2= Auto Exposure	Sets exposure time for image capture. See also register 0xA0C8 for using Auto Exposure.	0
0xA004	Preset shutter	R/W	4	0=Off; 1=1/100; 2=1/120; 3=1/250; 4=1/500; 5=1/1000; 6=1/2000; 7=1/4000; 8=1/8000; 9=1/15000; 10=1/25000; 11=1/75000; 12=1/100000; 13=1/150000; 14=1/300000	Fixed values for setting exposure	0
0xA008	Programmable exposure, PE	R/W	4	0 to 628 0= 1/8L ... 3.3us 1= 2/8L ... 6.7us 2= 3/8L ... 10.0us 3= 4/8L ... 13.3us 4= 1.5L ... 40.0us 5= 2.5L ... 66.7us : 627= 624.5L ... 16.7ms 628=625L ... 16.7ms (Shutter off)	Flexible setting of exposure time ranging from 3.3 μ s to 16.7 ms using the LVAL period (L) as increment. 1L is 26.7us.	628
0xA040	Trigger Mode	R/W	4	0=Continuous 1=Edge pre-select 2=Pulse width control 4=Reset Continuous 8=Sequential Trigger 16=Delayed Readout Trigger	It is possible to combine modes by adding register settings. E.g. set register to 17 (16 + 1) results in Delayed Readout Edge pre-selected Trigger	0
0xA04C	Smear-less	R/W	4	0=Off, 1=On	Smear reduction	0
0xA050	LVAL sync/ a-sync Accumulation	R/W	4	0=Sync, 1=Async	"Sync" means that accumulation starts at the next LVAL. "Async" means that accumulation starts immediately (no delay)	0
0xA054	Exposure Time Abs	R/W	4	3.3 μ s to 16.7 ms	Actual exposure time in microseconds, μ s. The camera will round value off to match LVAL increments.	166666 μ s
0xA080	Partial Scan	R/W	4	0=Full Frame 1=1/2 Partial 2=1/4 Partial 3=1/8 Partial		0
0xA084	Vertical Binning	R/W	4	0=OFF 1= 2 line binning 2= 3 line binning 3= 3 line binning		0
0xA0C0	AGC Select	R/W	4	0=OFF 1=ON	When off, the Manual Gain value applies	0
0xA0C4	Manual Gain Level	R/W	4	-256 to 255		0

CV-A10 GE / CV-A70 GE

0xA0C8	AGC and Auto Exposure Reference	R/W	4	1 to 1023	This register must be set for proper operation of AGC and Auto Exposure (.	0
0xA0CC	Black level	R/W	4	0 to 255		0
0xA180	Load Settings	W	4	0=Factory area 1=User area1 2=User area2 3=User area3	Allow the user to recall all camera settings.	1
0xA184	Save Settings into User area	W	4	1=User area1 2=User area2 3=User area3	Allows use to save all camera settings. Last used area number becomes new default.	1

Sequence function registers:

Address	Function	Read / Write	Size	Value / Range of value	Description	Default value
0xA208	Sequence Shutter 1	R/W	4	0 to 628	Pre-program 1 st shutter value	628
0xA20C	Sequence Shutter 2	R/W	4	0 to 628	Pre-program 2 nd shutter value	628
0xA210	Sequence Shutter 3	R/W	4	0 to 628	Pre-program 3 rd shutter value	628
0xA214	Sequence Shutter 4	R/W	4	0 to 628	Pre-program 4 th shutter value	628
0xA218	Sequence Shutter 5	R/W	4	0 to 628	Pre-program 5 th shutter value	628
0xA21C	Sequence Shutter 6	R/W	4	0 to 628	Pre-program 6 th shutter value	628
0xA220	Sequence Shutter 7	R/W	4	0 to 628	Pre-program 7 th shutter value	628
0xA224	Sequence Shutter 8	R/W	4	0 to 628	Pre-program 8 th shutter value	628
0xA228	Sequence Shutter 9	R/W	4	0 to 628	Pre-program 9 th shutter value	628
0xA22C	Sequence Shutter 10	R/W	4	0 to 628	Pre-program 10 th shutter value	628
0xA2A8	Save sequence settings	W	4	1: Save On	User area only	
0xA378	Sequence Gain 1	R/W	4	-256 to 255	Pre-program 1 st Gain value	0
0xA37C	Sequence Gain 2	R/W	4	-256 to 255	Pre-program 2 nd Gain value	0
0xA380	Sequence Gain 3	R/W	4	-256 to 255	Pre-program 3 rd Gain value	0
0xA384	Sequence Gain 4	R/W	4	-256 to 255	Pre-program 4 th Gain value	0
0xA388	Sequence Gain 5	R/W	4	-256 to 255	Pre-program 5 th Gain value	0
0xA38C	Sequence Gain 6	R/W	4	-256 to 255	Pre-program 6 th Gain value	0
0xA390	Sequence Gain 7	R/W	4	-256 to 255	Pre-program 7 th Gain value	0
0xA394	Sequence Gain 8	R/W	4	-256 to 255	Pre-program 8 th Gain value	0
0xA398	Sequence Gain 9	R/W	4	-256 to 255	Pre-program 9 th Gain value	0
0xA39C	Sequence Gain 10	R/W	4	-256 to 255	Pre-program 10 th Gain value	0
0xA3F0	Sequence Reset	W	4	1	Sequence Reset	

CV-A10 GE / CV-A70 GE

GigE Vision streaming related registers:

Address	Function	Read / Write	Size	Value / Range of value	Description	Default value
0xA400	Horizontal Image Size	R	4		return proper value when normal, V-bin & partial	767
0xA404	Vertical Image Size	R	4		return proper value when normal, V-bin & partial	576
0xA410	Video Pixel Format Type	R/W	4	0x01080001 0x01080003 0x01080009 0x0108000A 0x0110000D 0x0110000E	Mono8 Mono10 BAYRG8 (for 1/4 and 1/2 partial) BAYGB8 (for full and 1/8 partial) BAYRG10 (for 1/4 & 1/2 partial) BAYGB10 (for full & 1/8 partial)	Mono8 for CV-A10GE / BAYGB8 for CV-A70
0xA414	Transfer Rate	R/W	4	0=STD(30fps) 1=STD/2 2=STD/4 3=STD/8		0
0xA418	Software Trigger	R/W	4	31bit 30bit	Soft Trigger 0 Soft Trigger 1	0
0xA41C	ROI Mode	R/W	4	1=ROI1_ON / ROI2_Off 2=ROI1_Off / ROI2_ON 3=ROI1_ON / ROI2_ON	One or two ROIs can be set. They may not be overlapping	1
0xA420	ROI1 Size X	R/W	4		Width	W.Max
0xA424	ROI1 Size Y	R/W	4		Height	H.Max
0xA428	ROI1 Offset X	R/W	4		Horizontal offset	0
0xA42C	ROI1 Offset Y	R/W	4		Vertical offset	0
0xA44C	Video Sending Flag	R/W	4	0=Off, 1=On		0
0xA500	Payload length register	R	4		Number of bytes in a frame	
0xA504	Event ON/OFF Register	R/W	4	31 30 29 28 27	GEV_EVENT_TRIGGER GEV_EVENT_START_OF_EXPOSURE GEV_EVENT_END_OF_EXPOSURE GEV_EVENT_START_OF_TRANSFER GEV_EVENT_END_OF_TRANSFER	0

CV-A10 GE / CV-A70 GE

GPIO Registers:

0xA8B0	xTTL_LVDS Select	R/ W	4	0x00 0x01	TTL In 1, TTL IN active LVDS IN active	0
0xB000	Counter Clock source	R/ W	4	0x00 0x01	25MHz Pixel Clock	0
0xB004	Counter Divide by Value	R/ W	4	0x000 0x001 0x002 0xFFF	Bypass Divide by 2 Divide by 3 Divide by 4096	0
0xB008	Length Counter 0	R/ W	4	0x00001 to 0xFFFFF	Defines the length of the counter	1
0xB00C	Start point Counter 0	R/ W	4	0x00001 to 0xFFFFF	Defines the starting point of the counter	0
0xB010	Repeat, Counter 0	R/ W	4	0x00: infinite 0x01: 1 time 0xFF: 255 times	Defines the number of repeats (loops)	0
0xB014	End point Counter 0	R/ W	4	0x00001 to 0xFFFFF	Defines the end point of the counter	1
0xB018	Counter 0 Clear	R/ W	4	0 1 2 4 8	Free Run High Level Clear Low Level Clear Rising Edge Clear Falling Edge Clear	0
0xB01C	Length Counter 1	R/ W	4	0x00001 to 0xFFFFF	Counter length	1
0xB020	Start point Counter 1	R/ W	4	0x00001 to 0xFFFFF	Start Point	0
0xB024	Repeat Counter 1	R/ W	4	0x00: infinite 0x01: 1 time 0xFF: 255 times	Repeat Count	0
0xB028	End point Counter 1	R/ W	4	0x00001 to 0xFFFFF	End point	1
0xB02C	Counter 1 Clear	R/ W	4	0 1 2 4 8	Free Run High Level Clear Low Level Clear Rising Edge Clear Falling Edge Clear	0
0xB030	Length Counter 2	R/ W	4	0x00001 to 0xFFFFF	Counter length	1
0xB034	Start point Counter 2	R/ W	4	0x00001 to 0xFFFFF	Start Point	0
0xB038	Repeat Counter 2	R/ W	4	0x00: infinite 0x01: 1 time 0xFF: 255 times	Repeat Count	0
0xB03C	End point Counter 2	R/ W	4	0x00001 to 0xFFFFF	End point	1
0xB040	Counter 2 Clear	R/ W	4	0 1 2 4 8	Free Run High Level Clear Low Level Clear Rising Edge Clear Falling Edge Clear	0
0xB044	Length Counter 3	R/ W	4	0x00001 to 0xFFFFF	Counter length	1
0xB048	Start point Counter 3	R/ W	4	0x00001 to 0xFFFFF	Start Point	0

CV-A10 GE / CV-A70 GE

0xB04C	Repeat Counter 3	R/ W	4	0x00: infinite 0x01: 1 time 0xFF: 255 times	Repeat Count	0
0xB050	End point Counter 3	R/ W	4	0x00001 to 0xFFFFF	End point	1
0xB054	Counter 3 Clear	R/ W	4	0 1 2 4 8	Free Run High Level Clear Low Level Clear Rising Edge Clear Falling Edge Clear	0
0xB058	Selector CAMERA TRIGGER	R/ W	4	GPIO Selector: 0x00:CAMERA LVAL IN 0x01:CAMERA DVAL IN 0x02:CAMERA FVAL IN 0x03:CAMERA EEN IN 0x04:HIROSE TTL IN 1 0x05:HIROSE TTL IN 2 0x06:HIROSE TTL IN 3 0x07:HIROSE LVDS IN 0x09:SOFT TRIG 0 0x0D:Pulse Gen. 0 0x0E:Pulse Gen. 1 0x0F:Pulse Gen. 2 0x10:Pulse Gen. 3 0x7F:No Connection		0x7F
0xB064	Selector HIROSE TTL OUT 1	R/ W	4			
0xB068	Selector HIROSE TTL OUT 2	R/ W	4			
0xB06C	Selector Pulse Generator 0	R/ W	4			
0xB070	Selector Pulse Generator 1	R/ W	4			
0xB074	Selector Pulse Generator 2	R/ W	4			
0xB078	Selector Pulse Generator 3	R/ W	4			

10. External Appearance and Dimensions

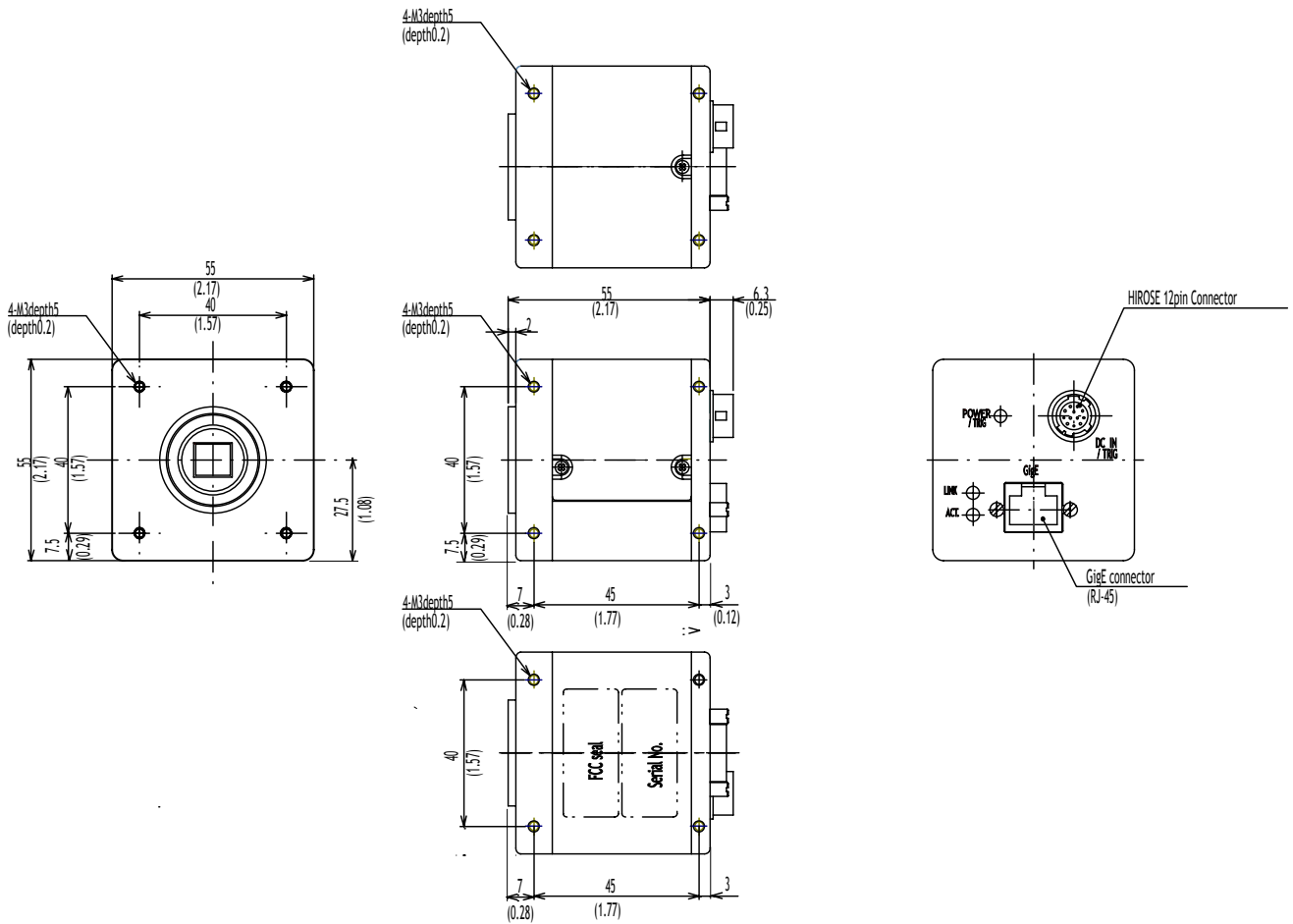

Fig. 23. Outline.

11. Specifications

11.1. Spectral response

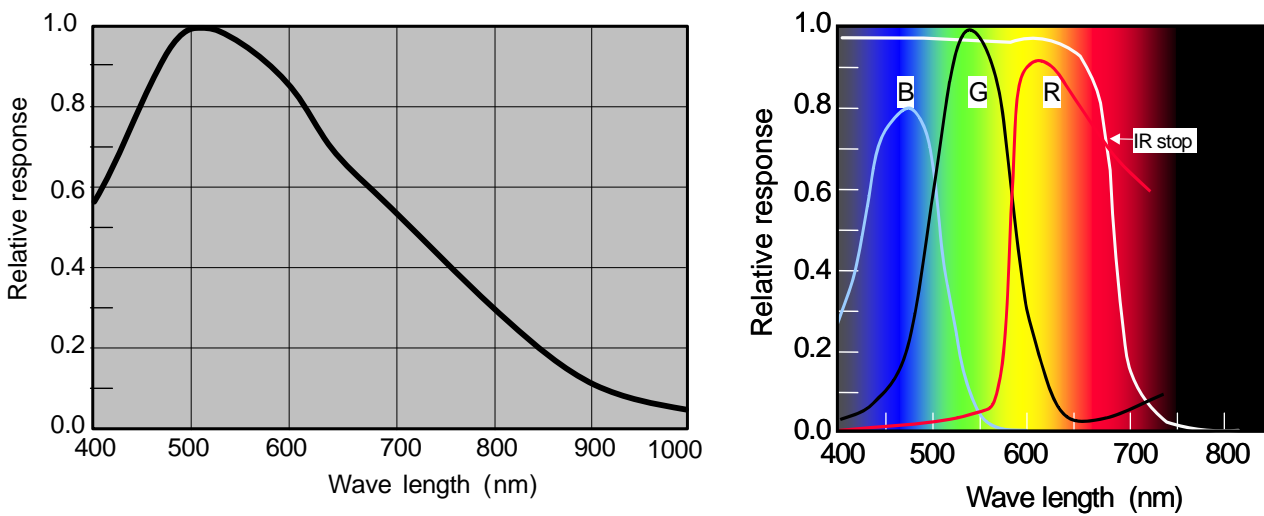

Fig. 24. Spectral response for CV-A10GE (left) and CV-A70GE (right)

CV-A10 GE / CV-A70 GE

11.2. Specification table

Specifications	CV-A10 GE / CV-A70 GE
Scanning system	Progressive scan
Frame rate full frame	60 frames/sec. Progressive (625 lines/frame)
Pixel clock	36.15 MHz
Line frequency	37.5 kHz (964 pixels clock/line)
CCD sensor	1/2" Monochrome ICX-415AL / 1/2" Bayer Mosaic ICX-415AK
Sensing area	6.49(h) x 4.83 (v) mm
Cell size	8.3 (h) x 8.3(v) μ m
Active pixels	767 (h) x 576 (v)
Readout modes. Full	767 (h) x 576 (v) 60 fps
1/2 partial	767 (h) x 287(v) 112 fps
1/4 partial	767 (h) x 143 (v) 177 fps
1/8 partial	767 (h) x 71 (v) 250 fps
Sensitivity (CV-A10GE)	(On sensor) 0.1 Lux (Max gain, Shutter OFF, $\gamma=1,50\%$ video) (On sensor) 4 Lux (Min. gain, Shutter OFF, $\gamma=1,100\%$ video)
Sensitivity (CV-A70GE)	(On sensor) 1.3 Lux (Max gain, Shutter OFF, $\gamma=1,50\%$ video) (On sensor) 9.1 Lux (Min. gain, Shutter OFF, $\gamma=1,100\%$ video)
S/N ratio	>55 dB (Gain = 0dB)
Video output. Digital	8/10 bit Gigabit Ethernet
Iris video output. Analogue	0.7 V p-p
Gain	Manual - automatic
Gain range	-3 to +12 dB
Gamma	1
Synchronization	Internal
Tracking range for H	37.50 KHz $\pm 1\%$
Trigger input.	4 V ± 2 V. TTL via Hirose 12 P connector or Via Gigabit Ethernet
Pulse output	EEN, FVAL, DVAL, via GPIO
Trigger modes	Edge Pre-Select(EPS), Pulse Width Control(PWC) ,Sequential Trigger, Delayed Read Out mode,
Accumulation	LVAL synchronous or asynchronous
Shutter speed EPS	1/60(OFF) to 1/300,000 second in 15 steps
Programmable exposure	1/60(OFF) to 1/300,000s (Continuous/EPS) , 2.0s to 1/15,000s (PWC)
Shutter speed PWC	2.5 lines (1/15,000 sec.) to 120 frames.
Auto shutter range	1/60(OFF) to 1/25,000 s (For Continuous only)
Readout modes	Partial scan. Full, 1/2, 1/4, 1/8 Vertical binning. Off, 1/2, 1/3, 1/4 (Only CV-A10GE) , Smear-less
Control interface	Gigabit Ethernet conforming to IEEE802.3 and AIA GigE Vision Standard Supports Jumbo frames: Packet size can be set from 1440 to 4040
GPIO functions	1) Clock generator (Programmable 12-bit counter) 2) Pulse generators(0 through 3. programmable 20 bit counters) 3) LUT (Cross point switch) with 13 inputs and 7 outputs LUT Input: LVAL, DVAL, FVAL, EEN, TTL in(3), LVDS in(1), Soft Trigger, Pulse gen. LUT Output: Trigger, TTL out(2), Pulse generators
Operating temperature	-10°C to +50°C
Humidity	20 - 80% non-condensing
Storage temp/humidity	-25°C to +60°C/20% to 80%
Vibration	10G (20Hz to 200Hz, XYZ directions)
Shock	70G
EMC	CE (EN61000-6-2 and EN61000-6-3), FCC part 15 class B
Power	12V DC $\pm 10\%$. Approx. 5.5 W. (<0.3746A)(1/8 partial)
Lens mount	C-mount (Flange back 17.526 mm -0.05mm) Image centre ± 0.1 mm from C-mount centre
Dimensions	55 x 55 x 55 mm (H x W x D)
Weight	Approx. 220g

Note: Above specifications are subject to change without notice

12. Appendix

12.1. Precautions

Personnel not trained in dealing with similar electronic devices should not service this camera. The camera contains components sensitive to electrostatic discharge. The handling of these devices should follow the requirements of electrostatic sensitive components.

Do not attempt to disassemble this camera.

Do not expose this camera to rain or moisture.

Do not face this camera towards the sun, extreme bright light or light reflecting objects.

When this camera is not in use, put the supplied lens cap on the lens mount.

Handle this camera with the maximum care.

Operate this camera only from the type of power source indicated on the camera.

Power off the camera during any modification such as changes of jumper and switch setting.

12.2. Typical Sensor Characteristics

The following effects may be observed on the video monitor screen. They do not indicate any fault of the camera, but do associate with typical sensor characteristics.

V. Aliasing

When the CCD camera captures stripes, straight lines or similar sharp patterns, jagged image on the monitor may appear.

Blemishes

All cameras are shipped without visible CCD sensor blemishes.

Over time some pixel defects can occur. This does not have a practical effect on the operation of the camera. These will show up as white spots (blemishes).

Exposure to cosmic rays can cause blemishes to appear on the CCD sensor. Please take care to avoid exposure to cosmic rays during transportation and storage. It is recommended using sea shipment instead of air flight in order to limit the influence of cosmic rays to camera.

Pixel defects/blemishes also may emerge due to prolonged operation at elevated ambient temperature, due to high gain setting or during long time exposure. It is therefore recommended to operate the camera within its specifications.

Patterned Noise

When the sensor captures a dark object at high temperature or is used for long time integration, fixed pattern noise may appear on the video monitor screen.

Caution when mounting a lens on the camera

When mounting a lens on the camera dusts particles in the air may settle on the surface of the lens or the CCD sensor of the camera. It is therefore important to keep the protective caps on the lens and the camera until the lens is mounted. Point the lens mount of the camera downward to prevent dust particles from landing on the optical surfaces of the camera. This work should be done in a dust free environment. Do not touch any of the optical surfaces of the camera or the lens.

Exportation

When exporting this product, please follow the export regulation of your own country.

12.3. References

1. This manual can for CV-A10GE/CV-A70GE can be downloaded from www.jai.com
2. Datasheet for CV-A10GE/CV-A70GE can be downloaded from www.jai.com
3. Specifications for the CCD sensor Sony ICX-415AL/ICX-415AK can be found on www.jai.com

Index

A		L	
Auto Iris Lens	18	Lens mount	5, 32
B		LVDS	6, 8, 9, 10, 32
Bayer mosaic filter.....	3	N	
Bit Allocation	1, 13, 14	Network Interface Cards	15
Blemishes	33	P	
C		partial scan	3, 4, 21
CAMERA TRIGGER	8, 10	Pin Assignment.....	6
Cat6 Ethernet.....	15, 16	Pixel Type.....	13, 14
CCD Sensor	19	Progressive scan	3
continuous.....	15, 16, 20, 21, 22, 25	Pulse Generators.....	7
Continuous mode.....	6	Pulse width control(PWC)	16
D		R	
Delayed Readout Mode	15, 29	Register	16, 29
E		RJ-45.....	5, 6
Edge pre-select(EPS)	16	ROI	28
Electronic Shutter.....	17	S	
Exposure Time Abs	17, 18	SDK.....	3, 4, 10, 15, 17, 29
F		Sequential trigger	16
Filter Driver	3	Software Development Kit	See SDK
G		Spectral response.....	31
GenICam	18	Switches/Routers.....	15
Gigabit Ethernet	6	T	
GigE Vision compliant	3, 15	transmission bandwidth	15
GigE Vision Streaming Protocol	13, 14	Trigger mode	25, 26, 27
GPIO.....	4, 5, 6, 7, 8, 10, 18, 28, 32	V	
H		Vertical Binning	16, 18
Hirose	6, 8, 9, 10, 15, 27, 32	X	
Host-based color interpolation	3	XML	3
I			
Inter-Packet Delay	15		

12. User's Record

Camera type: CV-A10 GE / CV-A70GE
Revision:
Serial No.
Firmware version.

For camera revision history, please contact your local JAI distributor.

User's Mode Settings.

User's Modifications.



DECLARATION OF CONFORMITY
AS DEFINED BY THE COUNCIL DIRECTIVE
89/336/EEC
EMC (ELECTROMAGNETIC COMPABILITY)
WE HEREWITH DECLARE THAT THIS PRODUCT
COMPLIES WITH THE FOLOWING PROVISIONS APPLYING TO IT.
EN61000-6-2
EN61000-6-3

Company and product names mentioned in this manual are trademarks or registered trademarks of their respective owners.
JAI A-S cannot be held responsible for any technical or typographical errors and reserves the right to make changes to products and documentation without prior notification.

Europe, Middle East & Africa

Phone +45 4457 8888
Fax +45 4491 8880

Asia Pacific

Phone +81 45 440 0154
Fax +81 45 440 0166

Americas

Phone (toll-free) +1 800 445 5444
Phone +1 408 383 0300

Visit our web site at www.jai.com



See the possibilities