



3 CCD RGB Color Camera

CV-M91

Operation Manual

Camera: Revision C
Manual: Version 1.2

Table of Contents

1. General.....	2
2. Standard Composition	2
3. Main Features	2
4. Locations and Functions	3
5. Pin Assignment	4
5.1. 12-pin Multi-connector (DC-IN/Trigger)	4
5.2. 6-pin Multi-connector (TRIGGER and RS232C)	4
5.3. 9-pin Sub D-connector (Video)	5
5.4. Input and Output Circuits.....	5
5.5. Prism unit	6
6. Functions and Operations	7
6.1. Input/Output of Signals	7
6.1.1. Input/output of HD/VD	7
6.1.2. Internal sync out/WEN out	8
6.1.3. Internal pixel clock out	8
6.1.4. VBS out on pin#4 12 pin.....	8
6.1.5. Y out/VBS out on pin#6 9 pin sub-D.....	8
6.1.6. Green out/sync on green on pin#4 9 pin sub-D.	8
6.2. Trigger Modes.....	9
6.2.1. Continuous Operation (Non triggered)	10
6.2.2. Edge Pre-select Mode	13
6.2.3. Pulse Width Control Mode	14
6.2.4. Start Stop Mode	15
6.2.5. Long time integration	16
6.3. Other Functions.	17
7. Configuring the Camera	18
7.1 Switch settings	18
7.1.1. SW1 on rear panel	18
7.1.2. Switch settings inside	18
7.2. Jumper settings inside	19
7.3. Switch and jumper positions	20
7.3. RS-232C control	21
7.4. CV-M91command list	21
7.5. Camera Control Tool for CV-M91	22
8. External Appearance and Dimensions	23
9. Specifications	23
9.1. Spectral sensitivity	23
9.2. Specification table.....	24
9.3. CV-M91 Opto-mechanical specifications	25
10. Appendix.....	26
10.1. Precautions	26
10.2. Typical CCD Characteristics.....	26
11. Users Record	27

1. General

The CV-M91 3 CCD RGB color camera is a new updated version of CV-M90. The prism is improved, and new CCD sensors are used. The new CCD sensor has 5 dB higher sensitivity, 15 dB lower smear and 4 dB higher dynamic range. Now there are Y/C output and input for composite sync. Pulse width control shutter is now fully implemented.

CV-M91 is a 3 CCD RGB color camera designed for machine vision and image processing applications where excellent resolution, high quality color reproduction are required.

The compact 3 CCD C-mount optical prism unit is designed for high color quality, and it allows use of a wide range of C-mount lenses.

CV-M91P is the CCIR PAL version, and CV-M91N is the EIA NTSC version.

Revision B has been updated with new boards.

Revision C has improved timing jitter specifications.

The latest version of this manual can be downloaded from: www.jai.com

The latest version of Camera Control Tool for CV-M91 can be downloaded from: www.jai.com

For camera revision history, please contact your local JAI distributor.

2. Standard Composition

The standard camera composition consists of the camera main body.

3. Main Features

- 3 CCD camera for vision applications
- 3 x 1/3" Hyper HAD CCD sensor
- CCIR: 752 (h) x 582 (v) pixels. EIA: 768 (h) x 494 (v) pixels
- Compact RGB prism for C-mount lenses
- Accepts standard C-mount lenses
- RGB output. PAL/NTSC Y/C and composite video output
- 570 TV lines horizontal resolution. S/N >54 dB
- CCD iris and AGC for automatic regulation
- Manual or one push white balance
- Interlaced / non-interlace. Frame or field accumulation
- Edge pre-select and pulse width control external trigger modes
- Start/stop exposure and long time exposure by external VD interval
- Internal or external synchronization on HD/VD or composite video
- Composite sync output or input
- HD/VD, WEN, EEN and pixel clock for easy interface
- Setup by switches or via serial port
- Setup by Windows 98/NT/2000 software via RS 232C

4. Locations and Functions

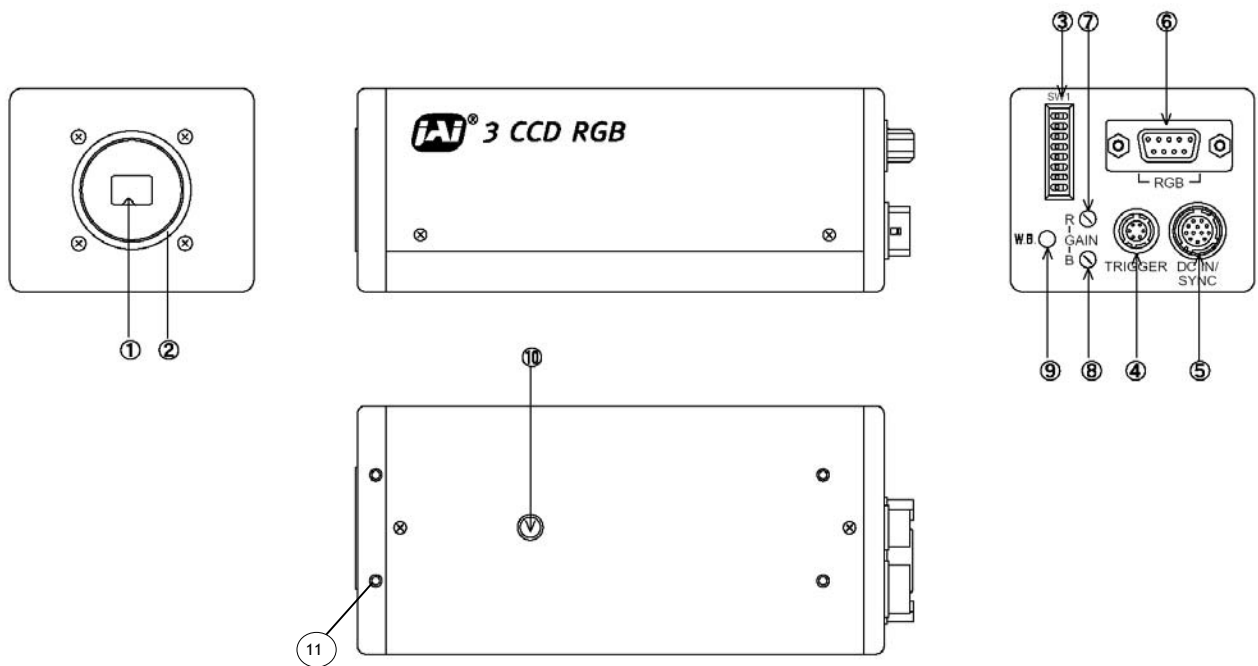

1. Prism
2. Lens mount (C-mount). Thread max 4 mm
3. Switch SW1 for mode settings
4. 6 pin Trigger input and RS-232C connector
5. 12 pin DC in/Sync connector
6. 9 pin Sub-D connector for video
7. Red gain potentiometer
8. Blue gain potentiometer
9. Switch for one push white balance
10. Mounting hole 1/4" for tripod. ¼ - 20
11. M3 mounting holes 4x

Fig. 1. Locations

5. Pin Assignment

5.1. 12-pin Multi-connector (DC-IN/Trigger)

Type: HR10A-10R-12PB-01(Hirose) male.
Plugs for cable: HR10A-10P-12S
(Seen from rear of camera.)

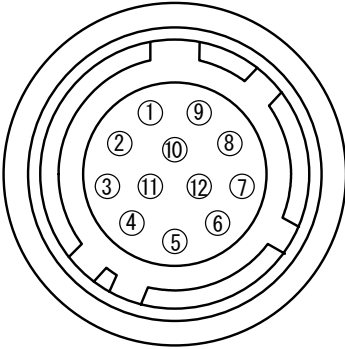

Fig. 2. 12-pin connector.

Pin no.	Signal	Remarks
1	GND	
2	+12 V DC input	
3	GND	N/C on old revision
4	NC/ <i>VBS</i> video out	*), <i>VBS</i> 75 Ω source SW604-1 on for <i>VBS</i> out
5	GND	
6	<i>HD in</i> /HD out	75 Ω term. By SW301-1 *), HD out 75 Ω source
7	<i>VS in</i> / <i>VD in</i> / <i>VD out</i>	75 Ω term. By SW301-2 *), <i>VD out</i> 75 Ω source
8	GND	
9	NC/Pixel clock out	*), 75 Ω source
10	GND	
11	+12 V DC input	
12	GND	

Notes:

Factory setting in ***bold italic***.

*) Alternative signal by internal switch/jumper
Refer to "7. Configuring the Camera."

5.2. 6-pin Multi-connector (TRIGGER and RS232C)

Type: HR10A-7R-6PB (Hirose) male
Plugs for cable: HR10A-7P-6S
Seen from rear.

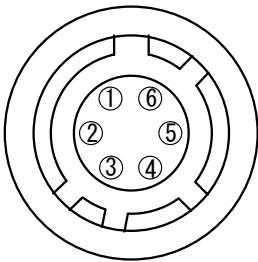

Fig. 3. 6-pin connector.

Pin no.	Signal	Remarks
1	TXD out	RS-232C
2	RXD in	RS-232C
3	GND	
4	EEN output	75 Ω source
5	Trigger input	75 Ω termination by int. switch SW301-3
6	WEN output	75 Ω source

Notes:

Refer to "7. Configuring the Camera."

EEN (Exposure Enable) pulse indicates the duration of the shutter, and can be used for controlling strobe illumination.
EEN will be low all the time in normal continuous mode if the shutter is off.

WEN (Write Enable) pulse indicates the period of effective video signal output. It is useful for setting the timing with framegrabber.

For schematic diagram of the input and output circuit with alternative settings refer to 5.3.

5.3. 9-pin Sub D-connector (Video)

Type: male.
(Seen from rear of camera.)

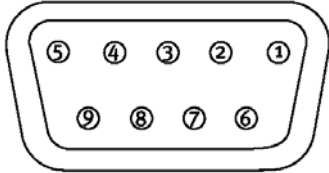

Fig. 4. 9-pin connector.

	Signal	Remarks
1	GND	
2	GND	
3	R output	75 Ω source.
4	<i>G out</i> or G+S output	75 Ω source. *), SW604-4 off for G out
5	B output	75 Ω source
6	<i>Y video out</i> or VBS out	75 Ω source. *), SW604-2 off -3 on for Y out
7	<i>Sync out</i> or WEN out	75 Ω source *), JP303 o JP304 c for Sync out
8	GND	
9	C video out	75 Ω source

Notes:

Factory setting in ***bold italic***.

*) Alternative signals by internal switch/jumper.
Refer to "7. Configuring the Camera."

5.4. Input and Output Circuits

In the following schematic diagrams the input and output circuits for video and timing signals are shown.

Video outputs

The video output is a 75 Ω DC coupled circuit.
The video DC level for video and video + sync are shown with 75 Ω termination.

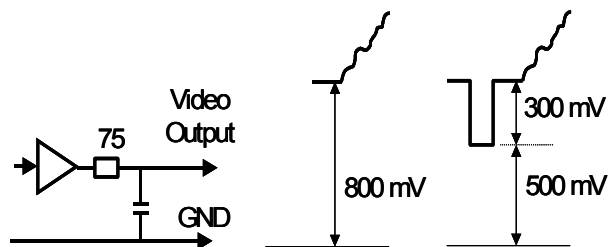

Fig. 5. Video output.

HD, VD and Trigger input

The inputs are AC coupled.
Input level 4 V ± 2 V.
The trigger input impedance is high. It can be 75 Ω terminated by closing the switch.

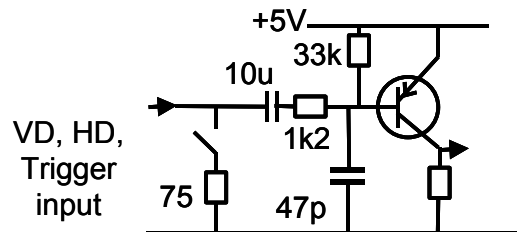

Fig. 6. HD, VD and Trigger input.

HD, VD, WEN, EEN and PCLK output

The output circuit for HD, VD, WEN, EEN and PCLK are complementary emitter followers with 75 Ω in series. Output level is 4V. (Non-terminated).

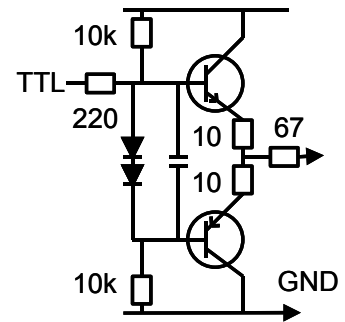

Fig. 7. HD and VD output.

5.5. Prism unit

For best color performance, the lens should be designed for 1/3" 3CCD camera. Otherwise color shading can be a problem.

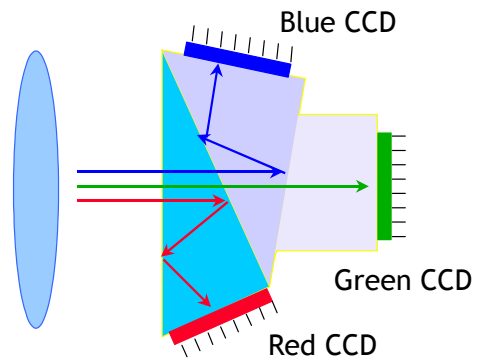

Fig. 9. Principle for prism unit.

6. Functions and Operations

The different camera modes and functions can be set by switches and jumpers. Some functions like RGB setup and white clip can only be changed via RS-232C. Function names within " " are names used in camera control tool.

6.1. Input/Output of Signals

6.1.1. Input/output of HD/VD

In the default setting the camera will accept external HD/VD signals on pin 6 and 7 of the 12 pin Hirose connector. If external HD/VD is applied, the camera will synchronize to it. If no external sync signals are applied, the camera will operate with its internal x-tal controlled sync.

The time requirements to the relation between VD and HD are shown in fig. 10.

The input is TTL level as factory setting. It can be 75 Ohm terminated by an internal switch. Internal HD/VD signals can be output on pin 6 and 7 by internal jumper settings. The output is TTL level from a 75-Ohm source. In trigger modes a VD pulse will only be output after an external trigger pulse.

Refer to "7. Configuring the Camera."

To use this mode:

Set function on PK8407: JP305 s, JP306 o for ext. VD input. *Factory default.*
 JP308 s, JP309 o for ext. HD input. *Factory default.*
 SW301-1(HD), SW301-2(VD) to OFF for TTL level. *Factory default.*
 SW301-1(HD), SW301-2(VD) to ON for 75 Ω termination
 JP305 o, JP306 s for int. VD output
 JP308 o, JP309 s for int. HD output

Input/output: Ext. VD in or int. VD out on pin 7 on 12-pin connector.
 Ext. HD in or int. HD out on pin 6 on 12-pin connector.

If only a composite VS signal is available, it is possible to enable an internal sync separator to separate HD and VD from the composite signal.

To use this mode:

Set jumper on PK8407: JP312 s, JP313 o, JP315 o, JP318 s, JP319 o for HD/VD input. *Default.*
 JP312 o, JP313 s, JP315 s, JP318 o JP319 s for comp. VS input.

Input Ext. VS (1Vpp \pm 30%) on pin 7 on 12 pin connector.

Important notes on using this mode.

- External sync system should follow the camera scanning system
- Requirements to HD/VD phase is shown in fig. 10

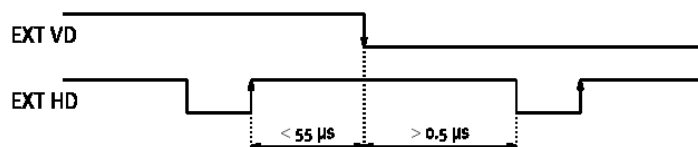

Fig. 10. Ext. HD and VD phase conditions.

6.1.2. Internal sync out/WEN out

On pin #7 on 9 pin sub-D connector, the factory setting is the internal composite sync signal out. By jumper settings it can be changed to WEN out. Refer to "7. Configuring the Camera."

To use this mode:

Set function on PK8407: JP303 o, JP304 s for sync output. *Factory default.*
JP303 s, JP304 o for WEN output.

6.1.3. Internal pixel clock out

The internal pixel clock can be output on pin #9 on the 12 pin connector. As factory setting it is not connected. Refer to "7. Configuring the Camera."

To use this mode:

Set function on PK8407: JP310 o, for no pixel clock out. *Factory default.*
JP310 s, for pixel clock out.

Important notes on using this mode.

- If not used, the pixel clock should not be output.

6.1.4. VBS out on pin#4 12 pin.

On pin #4 on the 12 pin connector, the video signal can be output as a composite signal. Refer to "7. Configuring the Camera."

To use this mode:

Set function on PK8404: SW604-1 on for VBS video signal out on pin #4 12 pin. *Factory default.*
SW604-1 off for no signal out on pin #4 12 pin.

6.1.5. Y out/VBS out on pin#6 9 pin sub-D.

The signal output on pin #6 on the 9 pin sub.D connector can be changed from Y output to composite video output. Refer to "7. Configuring the Camera."

To use this mode:

Set function on PK8404: SW604-2 off, SW604-3 on for Y out on pin #6 9 pin. *Factory default.*
SW604-2 on, SW604-3 off for VBS out on pin #6 9 pin.

6.1.6. Green out/sync on green on pin#4 9 pin sub-D.

The green signal output on pin #4 9 pin sub-D can be changed to be composite sync on green. Refer to "7. Configuring the Camera."

To use this mode:

Set function on PK8404: SW604-4 off for green video out on pin #4 9 pin. *Factory default.*
SW604-4 on for sync on green out on pin #4 9 pin.

6.2. Trigger Modes

This camera can operate in 5 primary modes. 1 non-triggered, 3 external H synchronous trigger modes and 1 long time integration mode.

- | | |
|-------------------------------------|--|
| 1. <i>Normal continuous Mode.</i> | Pre-selected exposure. |
| 2. <i>Edge Pre-select Mode.</i> | Pre-selected exposure. |
| 3. <i>Pulse Width Control Mode.</i> | Pulse width controlled exposure. |
| 4. <i>Start Stop Mode</i> | Exposure start on trigger, end after ext. VD |
| 5. <i>Long time integration</i> | Accumulation controlled by ext. VD interval |

In normal continuous mode and edge pre-select mode the shutter time can be selected from the 8 fixed steps. To avoid jitter, the trigger should be synchronized to HD as shown in fig. 11.

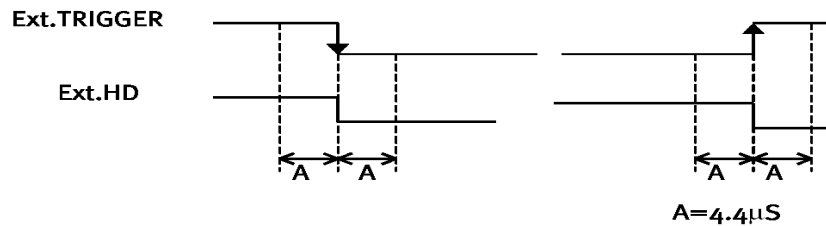

Fig. 11. Trigger/HD timing.

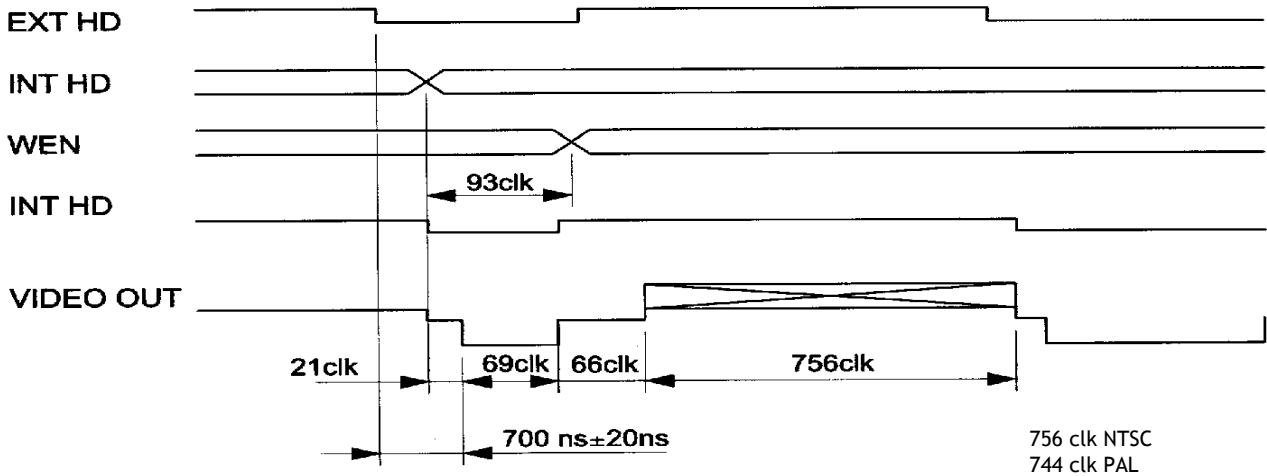

Fig. 12. Horizontal timing with ext. HD sync.

6.2.1. Continuous Operation (Non triggered)

Trigger Mode Normal. It is for applications where the camera is continuous running without external trigger. The shutter will work in all 8 steps up to 1/10,000 second. Refer to "7. Configuring the Camera."

To use this mode:

Set function: Trigger mode "Normal". SW1-4 to OFF
 On PK8407: JP301 open, JP302 open, JP331 short. *Factory setting.*
 Accumulation to "Frame" or "Field". SW 301-4 to ON or OFF
 Scanning to "Interlaced" or "Non-Interlaced". SW 1-5 to OFF or ON
 "Shutter Speed". SW1-1 through 1-3 to optimum
 Other functions

Important notes on using this mode.

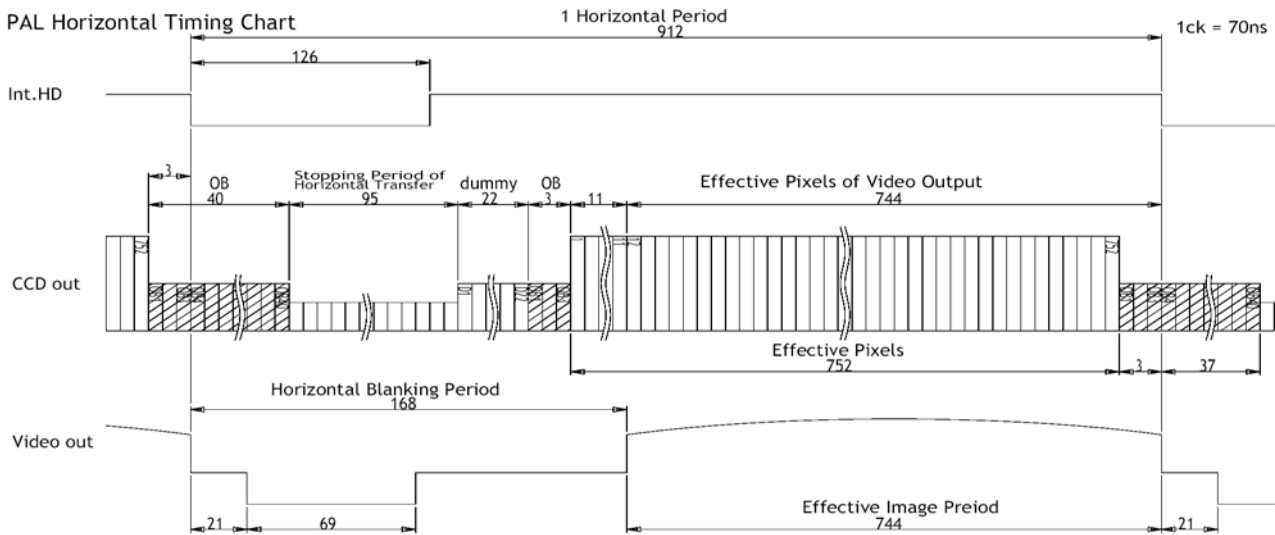

Fig. 13. PAL horizontal timing

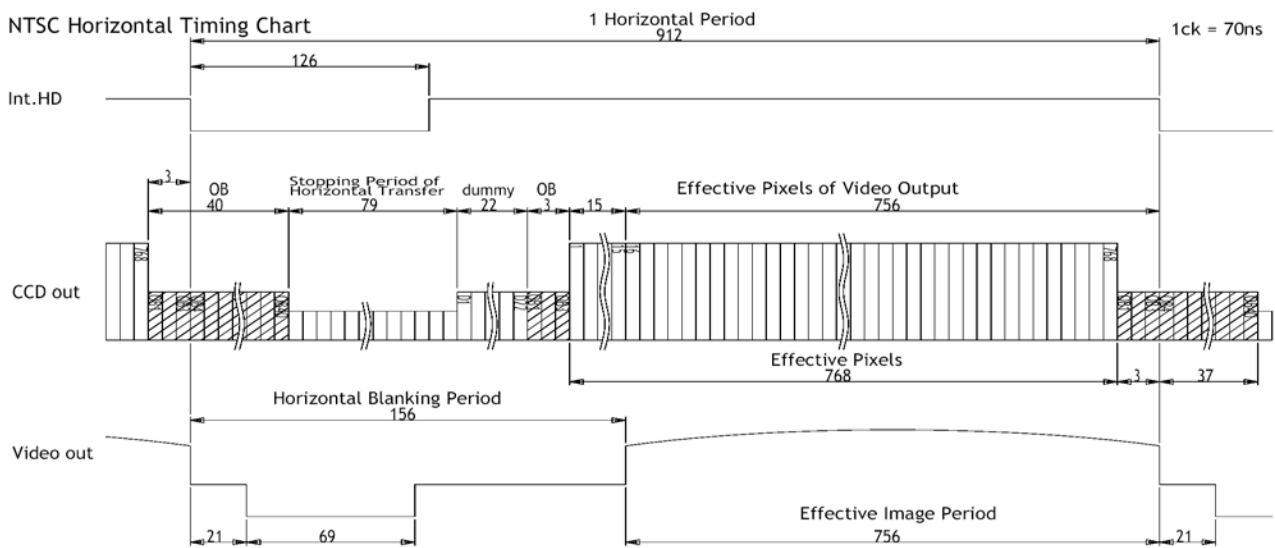

Fig. 14. NTSC horizontal timing

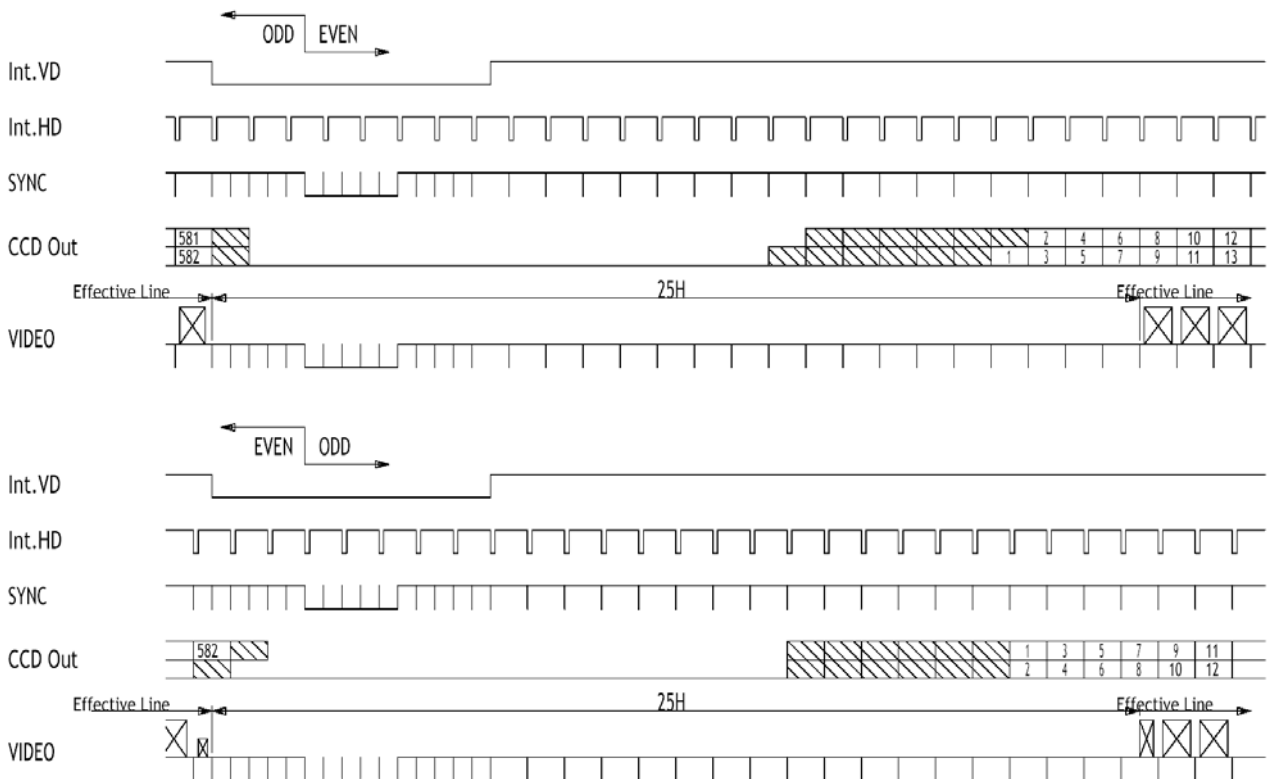

Fig. 15. Vertical timing PAL interlaced

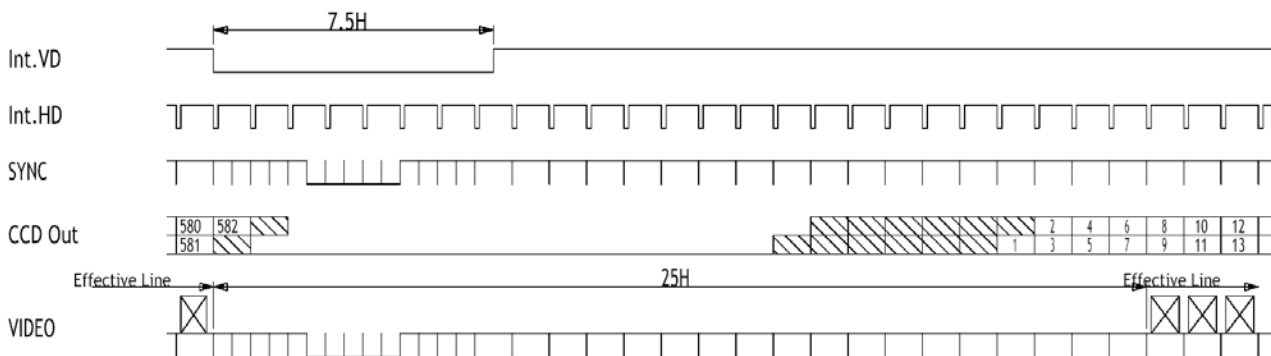

Fig. 16. Vertical timing PAL non-interlaced. Field accumulation

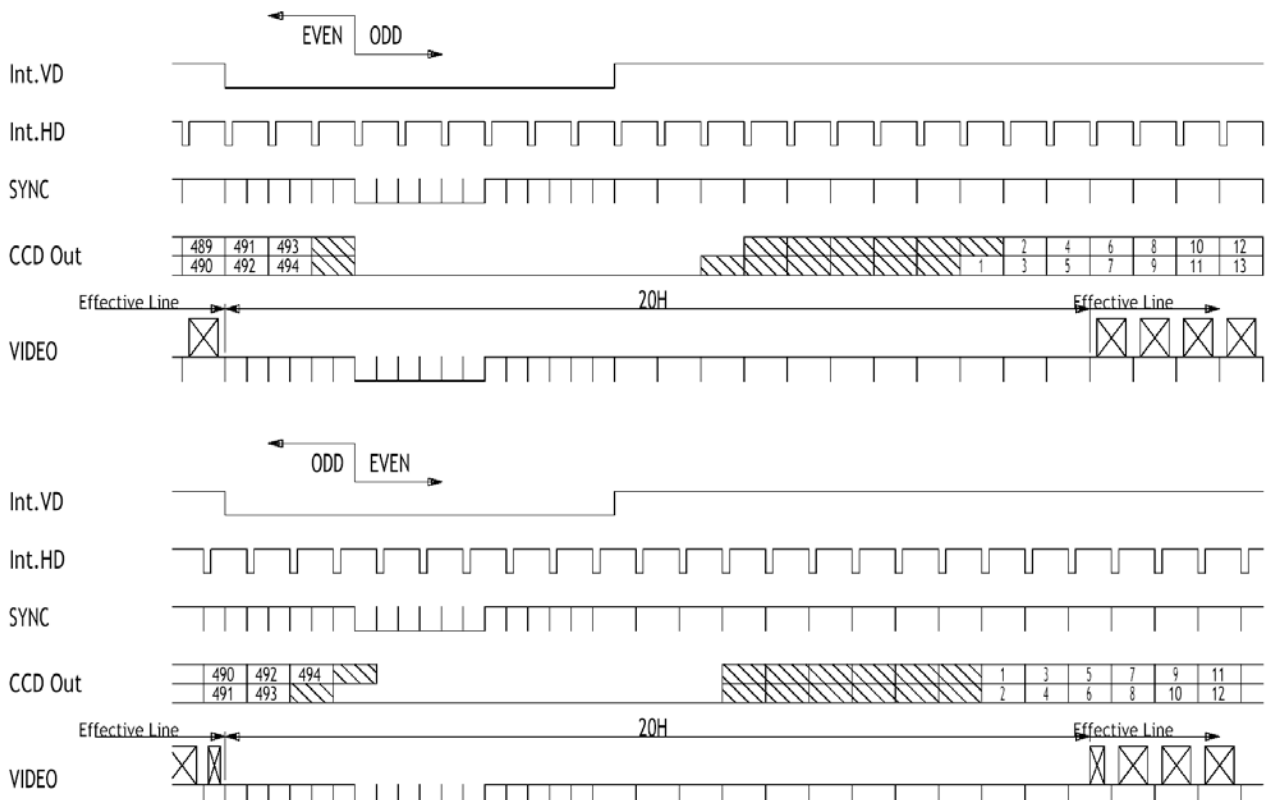

Fig. 17. Vertical timing NTSC interlaced

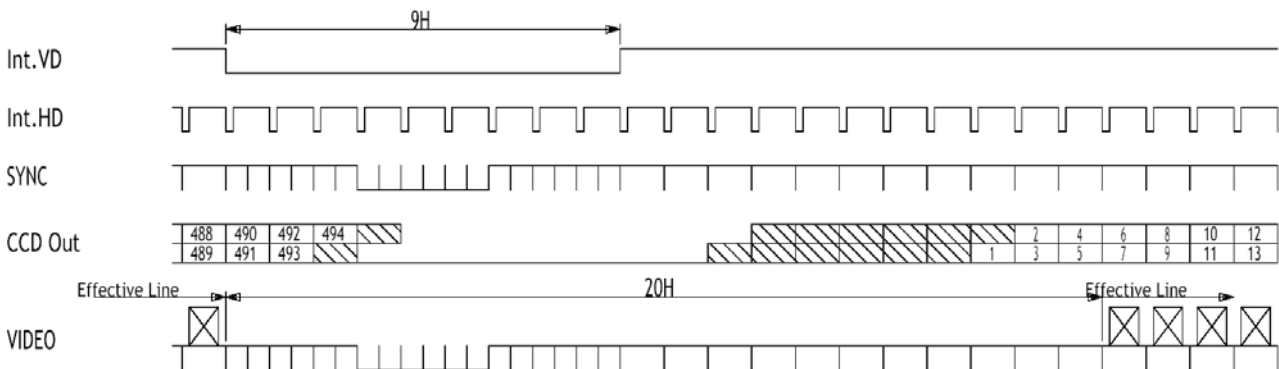

Fig. 18. Vertical timing NTSC non- interlaced. Field accumulation

6.2.2. Edge Pre-select Mode

The exposure will start at the first HD after the trigger leading edge, and it stops after the selected shutter time, and the resulting video is read out.

An EEN pulse indicate the accumulation time, and a WEN pulse that the resulting video read out. Refer to "7. Configuring the Camera."

To use this mode:

Set function: Trigger mode to "Edge pre-select". SW 1-4 to ON
 On PK8407: JP301 open, JP302 open, JP331 short. *Factory setting.*
 Accumulation to "Field". SW 301-4 to OFF
 Scanning to "Non-interlaced". SW 1-5 to ON
 "Shutter Speed". SW 1-1 through 1-3 to optimum
 Other functions

Input: Ext. trigger to pin 5 on 6-pin connector.
 Ext HD to pin 6 on 12 pin connector. (If used).

Important notes on using this mode.

- The duration of the trigger should be >1H. (>64μsec.)
- To avoid 1H jitter it is recommended to synchronize the trigger to HD. (See fig. 11.)
- A new trigger can not be applied before WEN is high

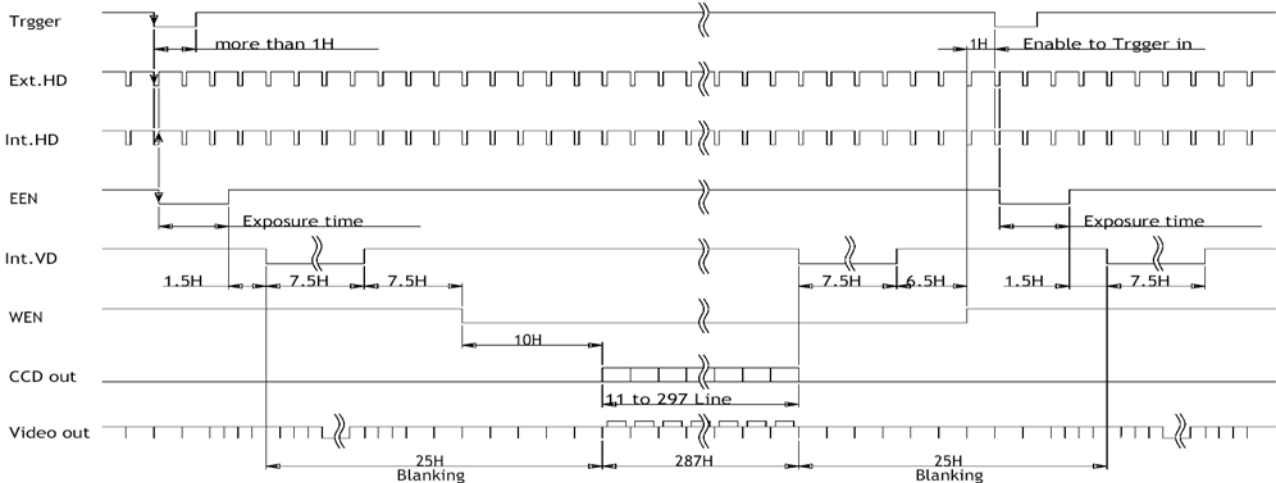

Fig. 19. Vertical timing for edge pre-select PAL

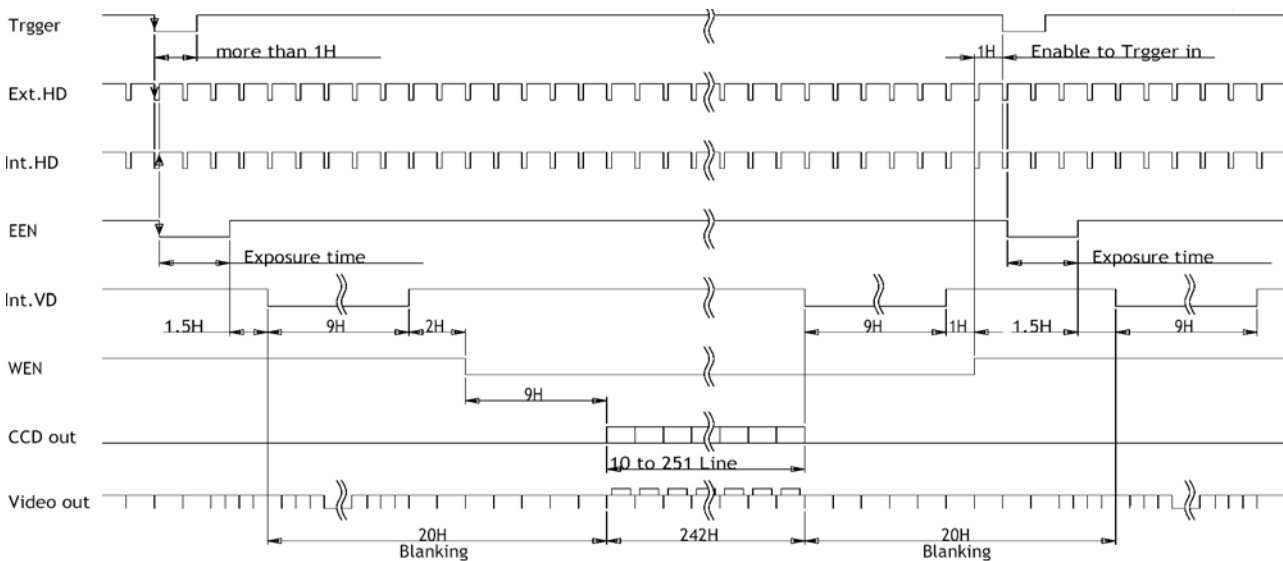

Fig. 20. Vertical timing for edge pre-select NTSC

6.2.3. Pulse Width Control Mode

The exposure will start at the first HD after the trigger leading edge, and it stops between the first and second HD after the trigger trailing edge. An EEN pulse indicate the accumulation time, and a WEN pulse indicates that the resulting video is read out. Refer to "7. Configuring the Camera."

To use this mode:

Set function: Trigger mode to "Pulse width control". SW 1-4 to ON
 On PK8407: JP301 open, JP302 open, JP311 open.
 Accumulation to "Field". SW 301-4 on PK8407 to OFF
 Scanning to "Non-interlaced". SW 1-5 to ON
 Shutter Speed to "1/10,000". SW 1-1 through 1-3 to ON
 Other functions

Input: Ext. trigger to pin 5 on 6-pin connector.
 Ext HD to pin 6 on 12 pin connector. (If used).

Important notes on using this mode.

- The duration of the trigger can be >1H to <900H. (>64 μsec. to <60msec.)
- To avoid 1H jitter it is recommended to synchronize the trigger to HD. (See fig. 11.)
- A new trigger can not be applied before WEN is high

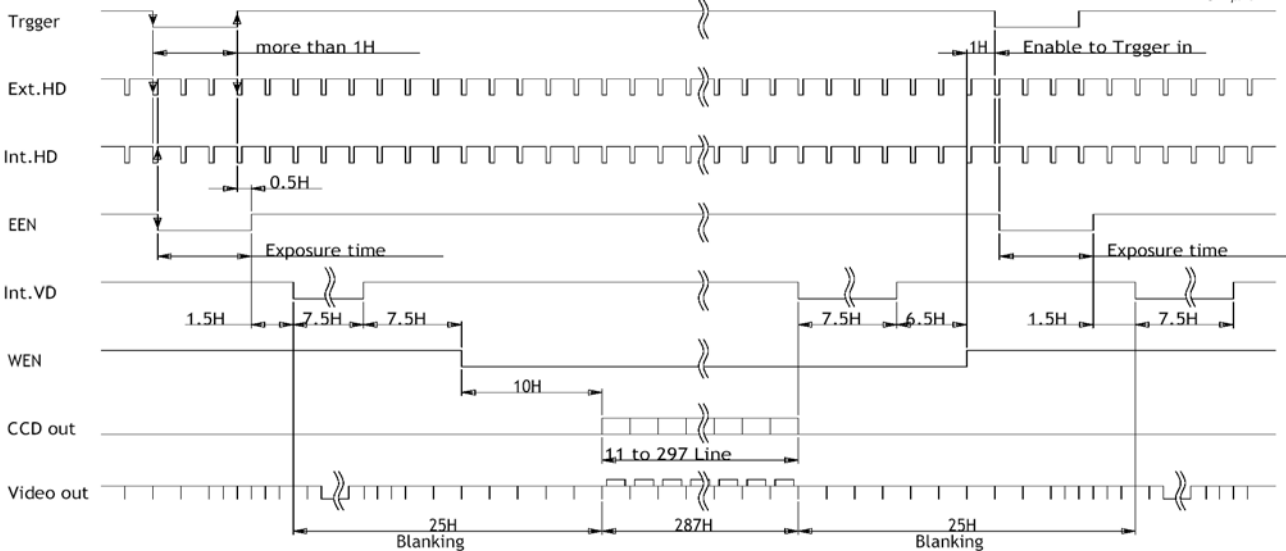

Fig. 21. Vertical timing for pulse width control PAL

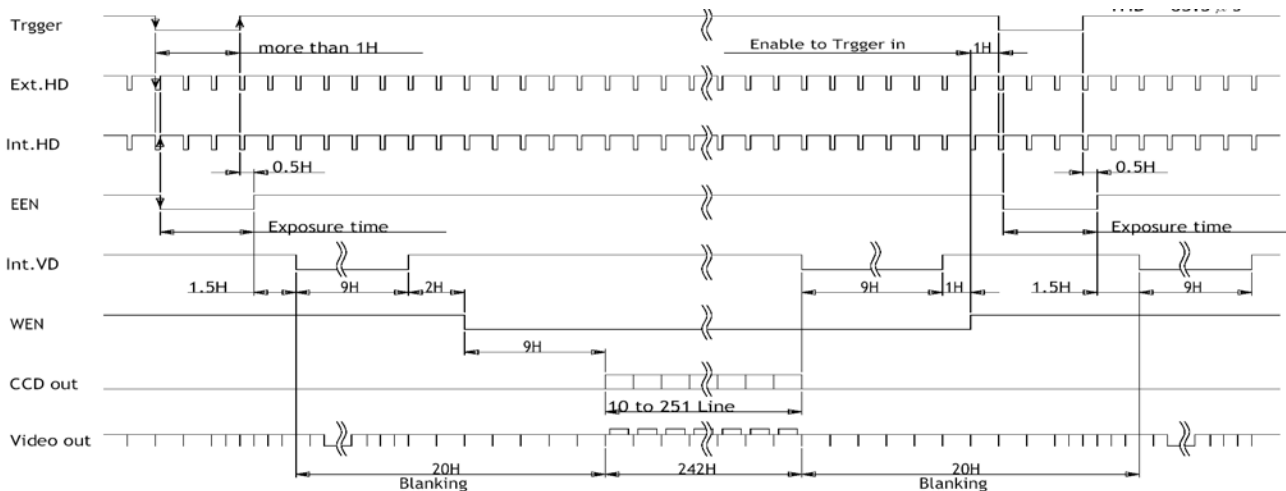

Fig. 22. Vertical timing for pulse width control NTSC

6.2.4. Start Stop Mode

The exposure time is controlled by the interval between the ext. trigger and the ext. VD signal. The exposure starts at the first HD pulse after the falling edge of the ext. trigger, and stops 14.5 H after the falling edge of the VD pulse. It means that the trigger pulse must be applied after the external VD pulse, for exposures less than 14.5 H. The range can be between 1/77 to 1/10,000. The Start/Stop mode is a continuous mode where the VD signal must be given continuously. It is not possible to input external VD randomly.

The difference between interlaced frame and field accumulation can be explained as follow. Both modes have 2 fields output in an interlaced frame. With frame accumulation, the contents in the ODD and EVEN sync fields will come from sensing field 1 and 2 on the CCD sensor. With field accumulation both ODD and EVEN sync fields will contain the signal from sensing field 1 and 2 added together. Non-interlaced field accumulation needs only 1 trigger pulse for each field.

Refer to "7. Configuring the Camera."

To use this mode:

- Set function: Trigger mode to "Start Stop". SW 1-4 to OFF
 On PK8407: JP301 short, JP302 open, JP311 short.
 Accumulation to "Field" or "Frame". SW 301-4 to OFF or ON
 Scanning to "Non-interlaced" or "Interlaced". SW 1-5 to ON or OFF
 Shutter Speed to "1/10,000 ". SW 1-1 through 1-3 to ON
 Other functions
- Input: Ext. trigger to pin 5 on 6-pin connector.
 Ext. VD to pin 7 on 12-pin connector
 (Ext. HD to pin 6 on 12-pin connector). Option

Important notes on using this mode.

- External sync system should follow the camera scanning system
- Requirements to HD/VD phase is shown in fig. 10

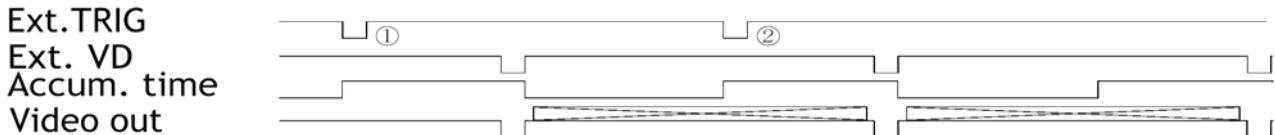

Fig. 23. Start stop interlaced field integration

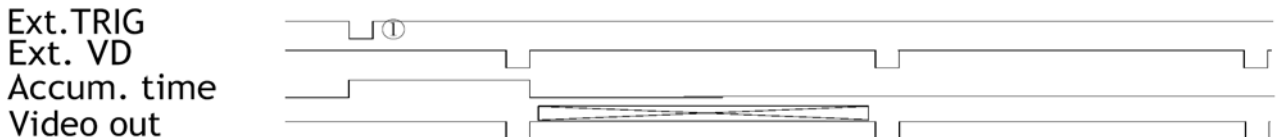

Fig. 24. Start stop interlaced frame integration

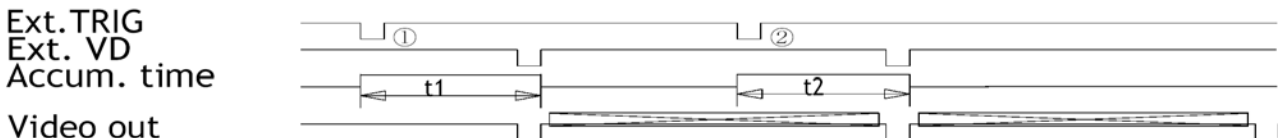

Fig. 25. Start stop non-interlaced field integration

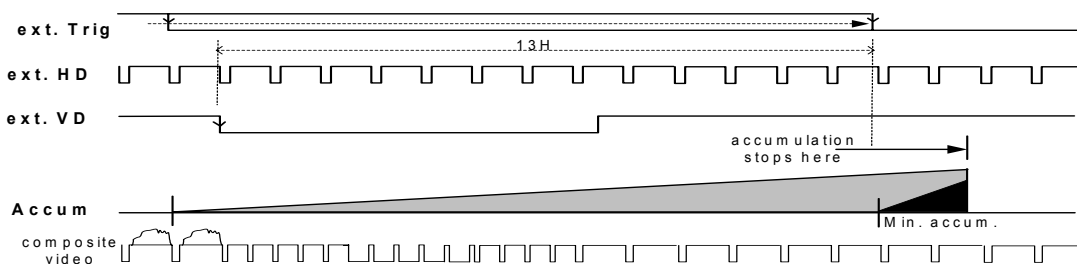

Fig. 26. Vertical timing details for start stop

6.2.5. Long time integration

The exposure time is the interval between 2 ext. VD pulses sent to the VD input. (Pin No. 7 of the 12-pin connector). The exposure starts after input of the first ext. VD pulse, and ends after the next input of the next ext. VD pulse, which again starts a new exposure. The long time exposure is a continuous process where each external VD will synchronize the camera, stop the exposure, start a new exposure and read out the previous accumulated signal. The exposure time can be selected in intervals of complete vertical timing periods. (Interlaced frame: EIA 525H and CCIR 625H. Non-interlaced field EIA 262H and CCIR 312H). Refer to "7. Configuring the Camera."

To use this mode:

Set function: Trigger mode to "Long Time integration". SW 1-4 to OFF
 On PK8407: JP301 open, **JP302 short**, JP311 short.
 Accumulation to "Field" or "Frame". SW 301-4 to OFF or ON
 Scanning to "Non-interlaced" or "Interlaced". SW 1-5 to ON or OFF
 Shutter Speed to "OFF ". SW 1-1 through 1-3 to OFF
 Other functions

Input: Ext. VD to pin 7 on 12-pin connector
 (Ext. HD to pin 6 on 12-pin connector). Option

Important notes on using this mode.

- The exposure range is from 1 field to ∞ . However it is recommended not to use exposure over 2 seconds due visible dark current signals.
- The ext. VD signal should follow the camera sync system and interlace setting.
- Requirements to HD/VD phase is shown in fig. 10.

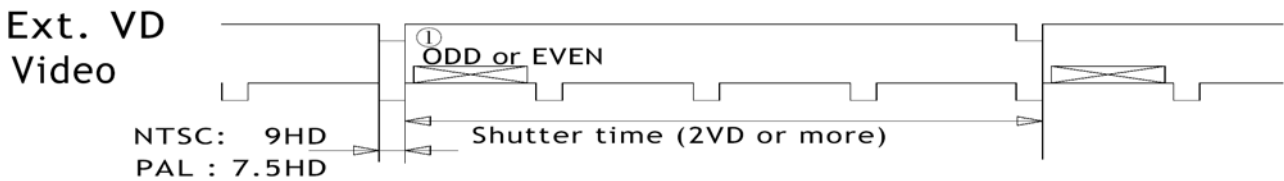

Fig. 27. Long time interlaced field integration

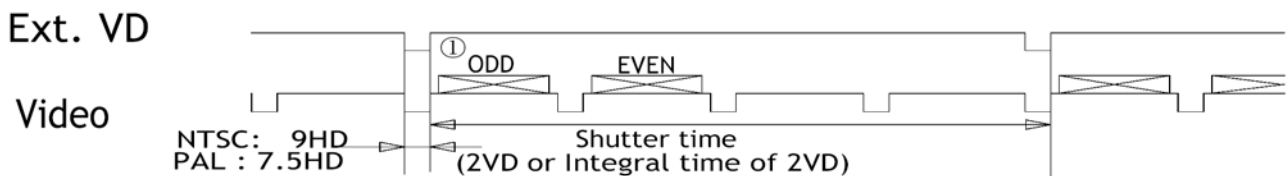

Fig. 28. Long time interlaced frame integration

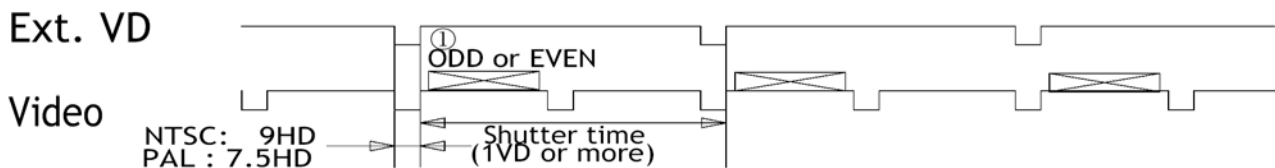

Fig. 29. Long time non-interlaced field integration

6.3. Other Functions.

Refer to "7. Configuring the Camera."

Scanning: SW1-5 on rear selects interlaced or non-interlaced. Non-interlaced PAL = 312H in EVEN field. Non-interlaced NTSC = 262 H in ODD field.

Gamma: SW1-6 on rear for gamma select. Gamma = 1 or gamma =0.45.

Gain: SW1-7 on rear select manual gain or AGC. Manual gain is set by VR7 on PK8406. In AGC the gain is automatic. The AGC level is set by potentiometer VR3.

Control: SW1-8 on rear selects the camera control mode. Either local by switches, or remote by "Camera Control Tool" via RS-232C. (*Should be in position before power on.*)

HD/VD in/out:

Jumper JP305 and JP306 on PK8407 are for switching between VD in/VD out.
Jumper JP308 and JP309 on PK8407 are for switching between HD in/HD out

75 Ohm termination:

SW301 on PK8407 can terminate signal inputs from TTL to 75 Ω .
SW301-1 for HD. SW301-2 for VD. SW301-3 for ext. trigger. (On for 75 Ω .)

VD/VS in: Jumper JP312, JP313, JP315, JP318 and JP319 on PK8407 select ext. HD/VD in or composite signal to the sync separator, which separate HV/VD.

Sync/WEN: Jumper JP303 and JP304 on PK8407 for Sync or WEN out on pin #7 on 9 pin sub-D.

Sync on green:

SW604 on PK8404 to ON for composite sync signal on green video output.

Pixel clock out:

Jumper JP301 on PK8407 short for pixel clock out on pin #9 on 12-pin connector.

Frame/field accumulation:

SW301-4 on PK8407 for frame or field accumulation.

CCD iris: SW201 on PK8408 to ON for CCD iris function in the regulation. The reference level can be set by potentiometer VR10 on PK8406.

One Push White Balance:

SW202 on PK8408 switch between manual and one push white balance. Manual allows the white balance to be set by R and B potentiometer on rear. One push is done automatic if switch on camera rear is pressed.

Red and Blue gain setting:

R and B gain potentiometer on camera rear is for manual white adjust.

Manual gain:

VR7 on PK8406 is for manual gain setting. *)

CCD iris setting:

VR10 potentiometer on PK8406 is for CCD iris reference level. *)

AGC setting:

VR3 potentiometer on PK8406 is for AGC reference level. *)

The following functions are for RS 232C control only.

Red, Green and Blue gain level. *)

Red, Green and Blue white clip level. Will set the clip level. (Normal 800 mV.). *)

Red, Green and Blue offset level. Will set the dark level. Normal 20 mV. *)

*) *Do not adjust these settings unless you are familiar with color camera adjustments.*

7. Configuring the Camera

7.1 Switch settings

The switch positions are shown in factory setting. Names in *bold italic* is factory setting.

7.1.1. SW1 on rear panel

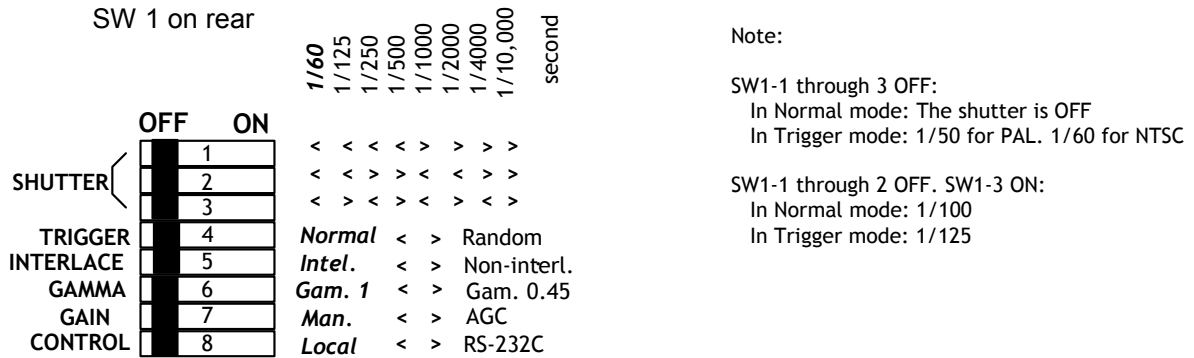

Fig. 30. Mode switch on camera rear

7.1.2. Switch settings inside

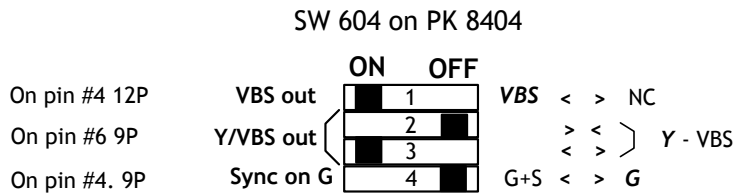

Fig. 31. Switch on PK8404 for video output.

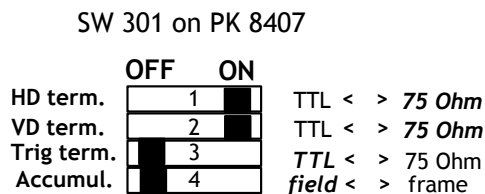

Fig. 32. Switch on PK8407 for 75Ω termination and accumulation.

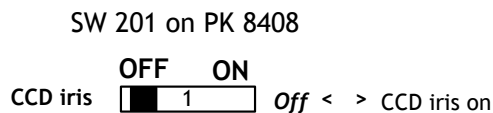

Fig. 33. Switch on PK8408 for CCD iris.

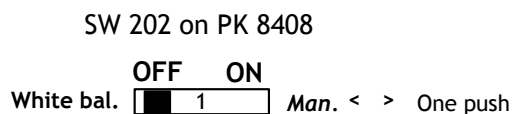

Fig. 34. Switch on PK8404 for white balance.

7.2. Jumper settings inside

Factory settings is shown in ***bold italic***

HD/VD input output on pin #6 and #7 on 12 pin connector.

Jumper	HD/VD in	HD/VD out	Remarks
JP305	<i>short</i>	open	VD input/output.
JP306	<i>open</i>	short	
JP308	<i>short</i>	open	HD input/output.
JP309	<i>open</i>	short	

HD/VD input on pin #6 and #7 or composite VS signal in on pin #7.

Jumper	HD/VD in	VS in	Remarks
JP312	<i>short</i>	open	Instead of HD and VD input on pin #6 and pin #7 a composite signal VS can be input on pin #7. The internal sync separator will then separate HD and VD.
JP313	<i>open</i>	short	
JP315	<i>open</i>	short	
JP318	<i>short</i>	open	
JP319	<i>open</i>	short	

Sync out/WEN out on pin #7 on 9 pin sub-D connector.

Jumper	Sync out	WEN out	Remarks
JP303	<i>open</i>	short	
JP304	<i>short</i>	open	

Pixel clock out on pin #9 on 12 pin on 12 pin connector.

Jumper	N. C.	Pix clk out	Remarks
JP310	<i>Open</i>	short	Keep JP310 open if pixel clock is not used.

Mode setting by internal jumpers

Jumper	Normal	Edge pre-s	Pulse width	Start/stop	Long time	Remarks
JP311	<i>short</i>		<i>open</i>	short	short	
JP301	<i>open</i>		open	<i>short</i>	open	
JP302	<i>open</i>		open	open	<i>short</i>	

7.3. Switch and jumper positions

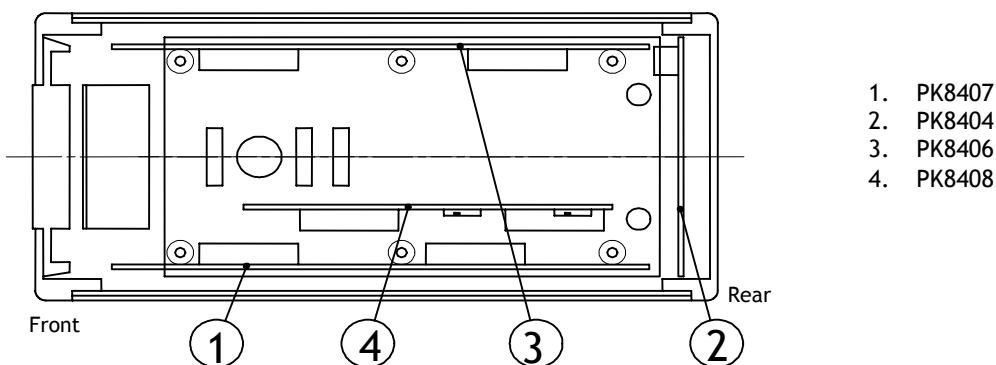

Fig. 35. Board positions.

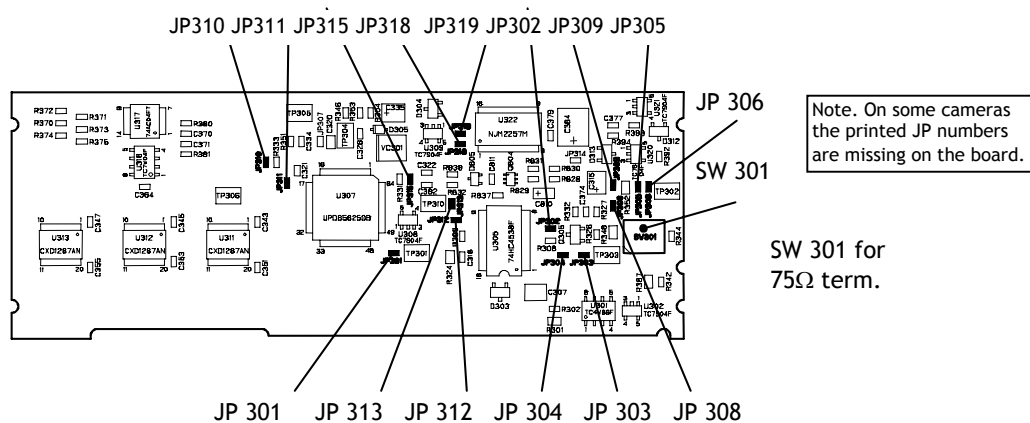

Fig. 36. Jumpers and switches on PK8407.

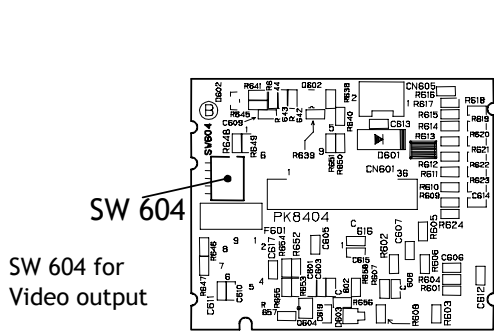

Fig. 37. Switches on PK8404.

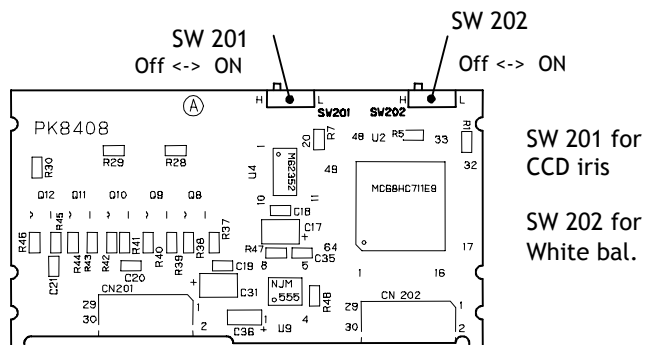

Fig. 38. Switches on PK8408.

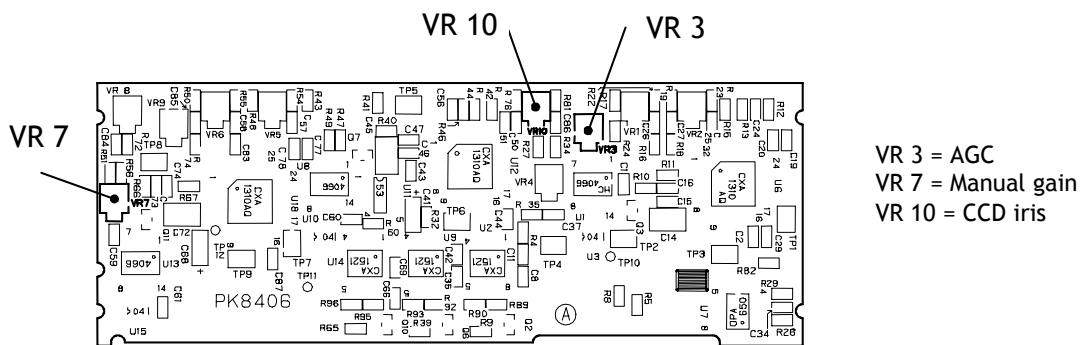

Fig. 39. Potentiometers on PK8406.

7.3. RS-232C control

The CV-M91 camera functions can be set up via the RS-232C port on the 6 pin HR connector. The JAI camera control tool for CV-M91 can be used for it.

To use this mode:

Set function: Control. SW1-8 on rear to ON. RS-232C. (Switch setting before power on).

Other functions

Important notes on using this mode.

-

Communication setting.

Baud Rate	9600 bps
Data Length	8 bit
Start Bit	1 bit
Stop Bit	1 bit
Parity	None
Xon/Xoff Control	None

RS 232C cable

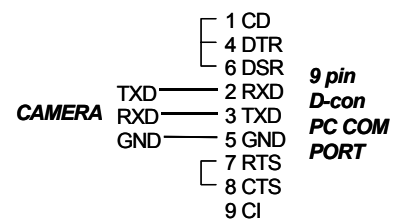

7.4. CV-M91 command list

The following functions can be controlled via the camera control tool.

Shutter speed

1/60 to 1/10,000 sec.

Mode

Normal, random trigger

Scanning

2.1 interlaced, non-interlaced

Accumulation

Frame, field

Gamma

Gamma 1.0, gamma 0,45

AGC

AGC off, AGC on, manual gain, AGC reference level

CCD iris

CCD iris on. CCD iris off, CCD iris reference level

White balance

One push, manual, red gain, blue gain, green gain

White clip level

Red white clip, blue white clip, green white clip

Offset level

Red offset, blue offset, green offset

Load user settings

Load factory, user 1, user 2

Save user settings

Save user 1, save user 2. (Last saved user settings become default at next power-up.)

7.5. Camera Control Tool for CV-M91

From www.jai.com Camera Control Tool for Windows 98/NT/2000 can be downloaded. The control tool contains a camera control program and tools for making your own program. For the integrator and experienced user, the Camera Control Tool is much more than a program with a window interface. It also provides an easy and efficient ActiveX interface built for MS Windows 98, ME, NT and 2000. The OCX interface has the ability to connect to the camera using the serial interface of the PC by reading and writing properties for the camera. This integration requires simple programming skills within Visual Basic, Visual C++ or similar languages in a Microsoft Windows environment.

Below the different windows are shown.

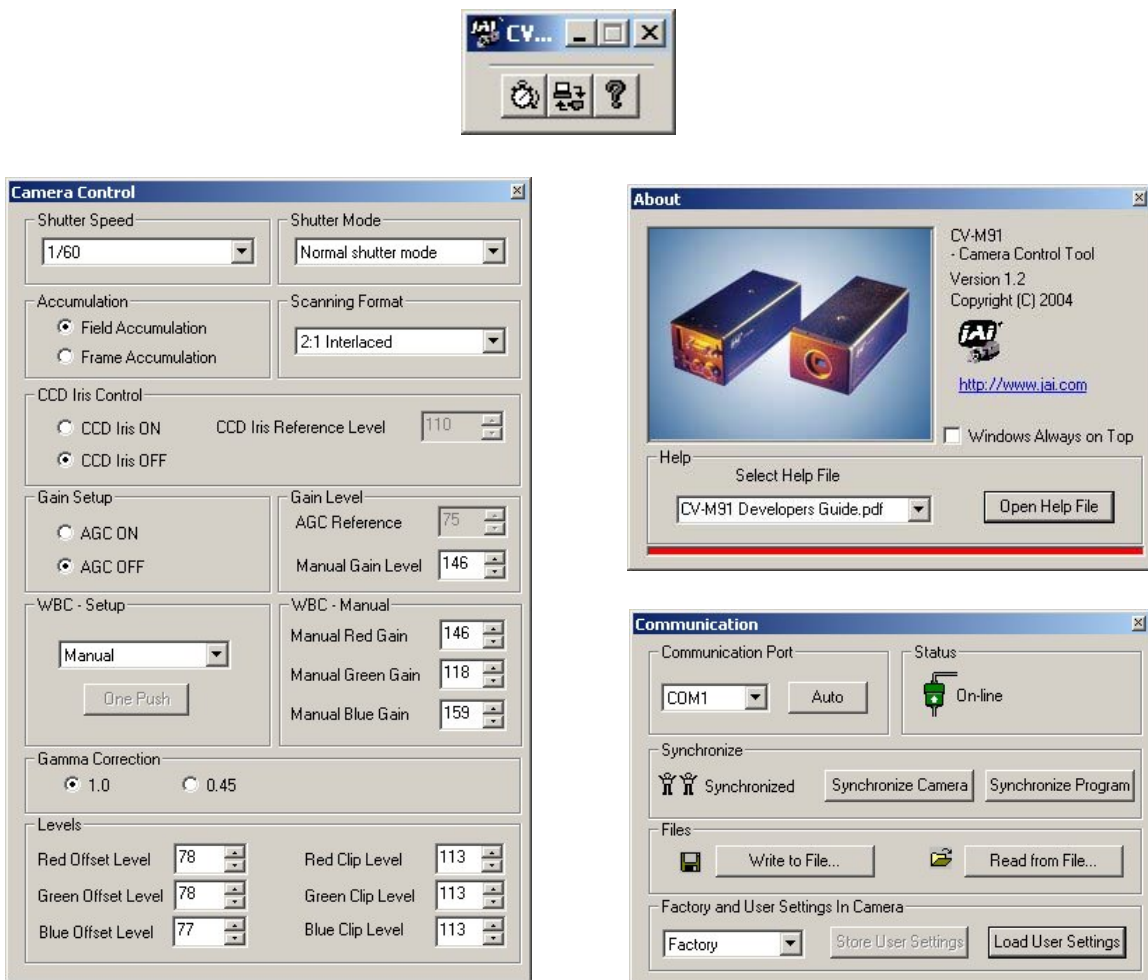
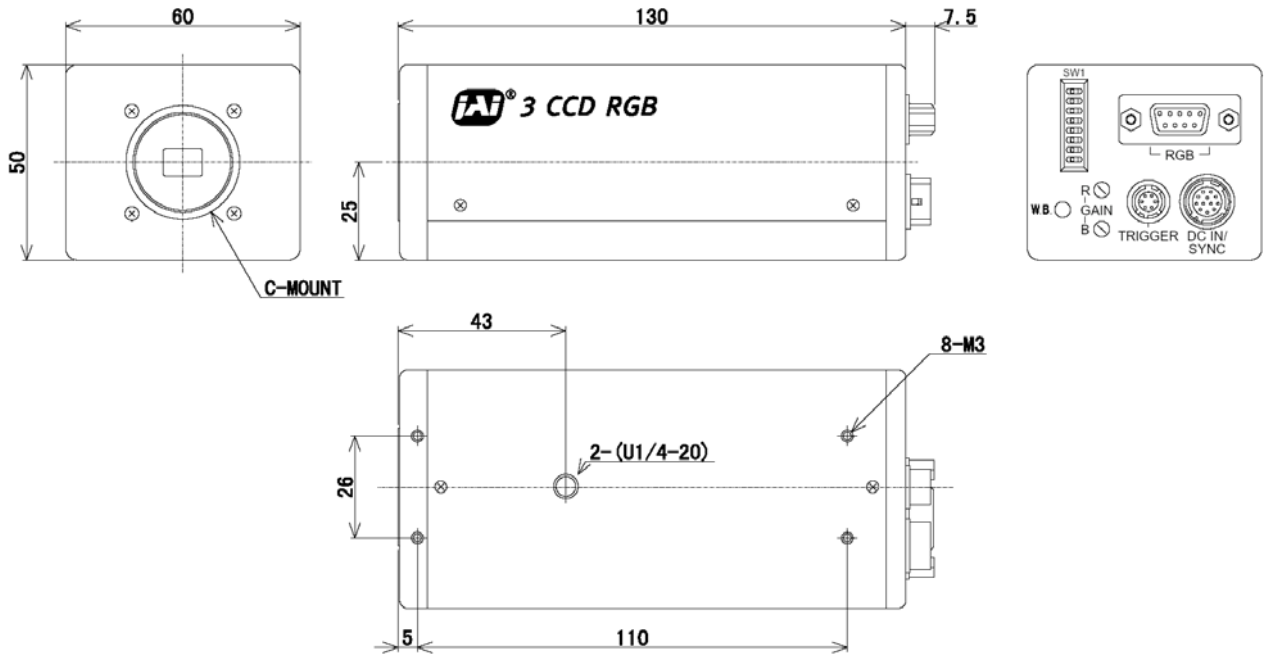

Fig. 40. Window from camera control tool

8. External Appearance and Dimensions



Important notes.

- C-mount thread on lens should be less than 4.0 mm.
- Use only lenses designed for 1/3" 3 CCD cameras.

Fig. 41. Outline.

9. Specifications

9.1. Spectral sensitivity

The resulting relative response for the prism, the IR stop and the CCD sensor characteristics combined.

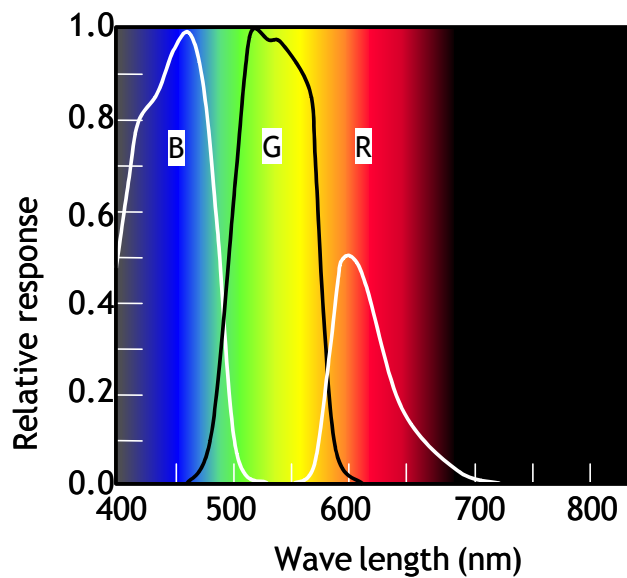

Fig. 42. Spectral sensitivity for CV-M91

CV-M91

9.2. Specification table

Specifications	CV-M91P	CV-M91N
Scanning system	CCIR PAL, 25 frames/sec. 625 lines, 2:1 Interlaced	EIA NTSC. 30 frames/sec. 525 lines, 2:1 Interlaced
Frame rate	50 Hz	59.94 Hz
Line frequency	15.625 kHz	15.734 kHz
Pixel frequency	14.25 MHz	14.349949 MHz
CCD sensors	3 x 1/3" monochrome IT CCD ICX-409AL-6	3 x 1/3" monochrome IT CCD ICX-408AL-6
Sensing area	4.8 (h) x 3.6 (v) mm	
Effective pixels	752 (h) x 582 (v)	768 (h) x 494 (v)
Pixels in video output	744 (h) x 575 (v)	765 (h) x 486 (v)
Cell size	6.5 (h) x 6.25 (v) μ m	6.35 (h) x 7.4 (v) μ m
Resolution horizontal	570 TV lines	
Sensitivity (on sensor)	0.5 Lux, Max gain, 50% video	
S/N ratio	54 dB	56 dB
Video outputs. (DC coupled)	RGB Y/C PAL VBS PAL	RGB Y/C NTSC VBS NTSC
Video output level	RGB and C signal, 0.7 Vpp, 75 Ω G on sync, Y signal and Composite VS, 1.0 Vpp, 75 Ω	
Gamma	1.0 - 0.45	
Gain	Manual - Automatic	
Gain range	0 to +18 dB	
Accumulation	Field - Frame	
Synchronization	Int. X-tal. Ext HD/VD or random trigger	
Scanning	2:1 interlaced, non-interlaced	
Composite VS input	1.0 Vpp \pm 0.3V. 75 Ω terminated	
Composite sync output	4 Vpp from 75 Ω source	
HD/VD sync input	4 Vpp \pm 2 V. (Termination TTL or 75 Ω)	
HD/VD sync output	4 Vpp from 75 Ω source	
Trigger input	4 Vpp \pm 2 V. (Termination TTL or 75 Ω)	
WEN output (write enable)	4 Vpp from 75 Ω source	
EEN output (exposure enable)	4 Vpp from 75 Ω source	
Pixel clock output	4 Vpp from 75 Ω source	
Shutter.		
Continuous and Edge pre-select	(off), 1/100, 1/250, 1/500, 1/1000, 1/2000, 1/4000, 1/10,000 sec.	
Pulse width control input	1 H to 900 H	
Start/stop	1/10,000 to 1/77 second	
Long time exposure	1 field to ∞	
White balance	Manual, one push (2350 to 6400 K)	
Functions controlled by RS 232C	Trigger mode, Shutter speed, Accumulation, Interlace, AGC level, White clip, Set-up, Manual gain, AGC/manual gain, Internal/ potentiometer gain set, Gamma, white balance.	
Functions controlled by internal DIP switches	VD input/output, HD input/output HD, VD and Trigger 75 Ω termination on/off	
Operating temperature	-5°C to +45°C.	
Humidity	20 - 80% non-condensing	
Storage temp./humidity	-25°C to 60°C./20% - 90 % non-condensing	
Vibration	3 G (15 Hz - 200 Hz in XYZ)	
Shock	50 G	
Regulations	CE (EN 50081-1, EN 50082-1) FCC part 15	
Power	12V DC \pm 10%. 6 W	
Lens mount	C-mount. (Max 4.0 mm thread)	
Dimensions	50 x 60 x 130 mm (HxWxD)	
Weight	480 g	

9.3. CV-M91 Opto-mechanical specifications

Notes : All the measure tolerances indicated below are the worst values.

1) POSITION TOLERANCE OF LENS MOUNT TO CAMERA BODY

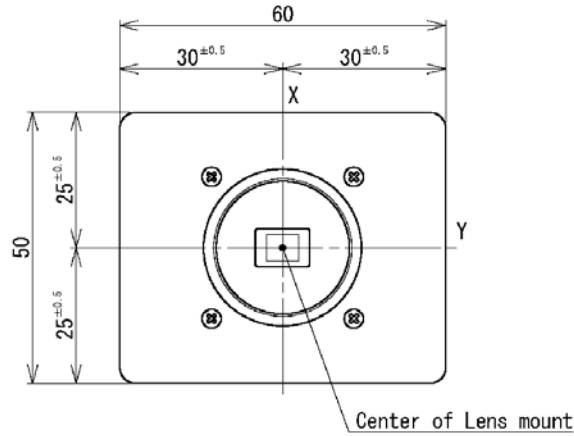

2) POSITION TOLERANCE OF BACK FOCAL LENGTH AND PARALLELISM TOLERANCE OF SENSOR TO LENS MOUNT

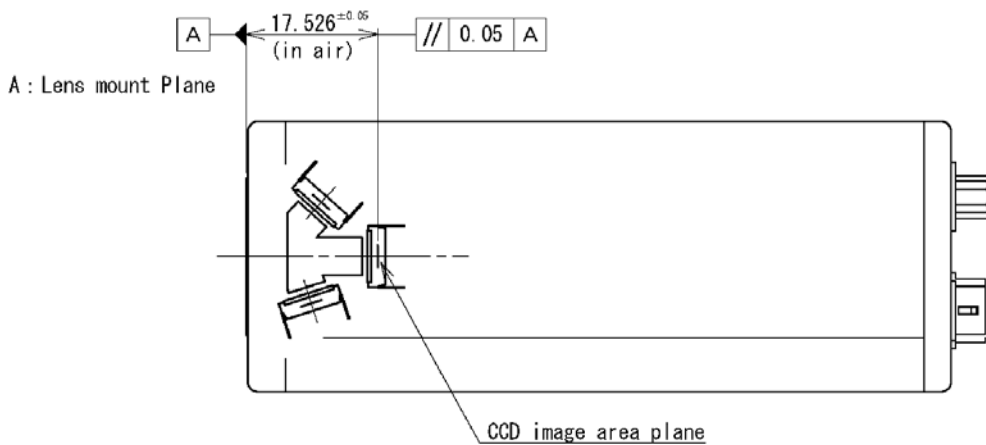

3) POSITION TOLERANCE OF SENSOR TO LENS MOUNT

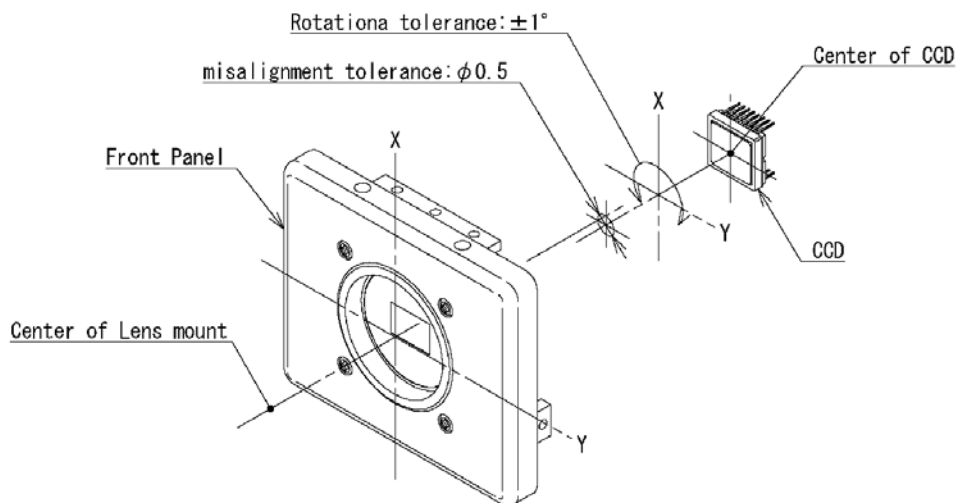

Fig. 43. Opto mechanical specifications.

10. Appendix

10.1. Precautions

Personnel not trained in dealing with similar electronic devices should not service this camera. The camera contains components sensitive to electrostatic discharge. The handling of these devices should follow the requirements of electrostatic sensitive components.

Do not attempt to disassemble this camera.

Do not expose this camera to rain or moisture.

Do not face this camera towards the sun, extreme bright light or light reflecting objects.

When this camera is not in use, put the supplied lens cap on the lens mount.

Handle this camera with the maximum care.

Operate this camera only from the type of power source indicated on the camera.

Power off the camera during any modification such as changes of jumper and switch setting.

10.2. Typical CCD Characteristics

The following effects may be observed on the video monitor screen. They do not indicate any fault of the CCD camera, but do associate with typical CCD characteristics.

V. Smear

Due to an excessive bright object such as electric lighting, sun or strong reflection, vertical smear may be visible on the video monitor screen. This phenomenon is related to the characteristics of the Interline Transfer System employed in the CCD.

V. Aliasing

When the CCD camera captures stripes, straight lines or similar sharp patterns, jagged image on the monitor may appear.

Blemishes

Some pixel defects can occur, but this does not have an effect on the practical operation.

Patterned Noise

When the CCD camera captures a dark object at high temperature or is used for long time integration, fixed pattern noise (shown as white dots) may appear on the video monitor screen.

11. Users Record

Camera type: CV-M91
Revision: (Revision C)
Serial No.

For camera revision history, please contact your local JAI distributor.

Users Mode Settings.

Users Modifications.



DECLARATION OF CONFORMITY
AS DEFINED BY THE COUNCIL DIRECTIVE
89/336/EEC
EMC (ELECTROMAGNETIC COMPABILITY)
WE HEREWITH DECLARE THAT THIS PRODUCT
COMPLIES WITH THE FOLOWING PROVISIONS APPLYING TO IT.
EN-50081-1
EN-50082-1

Company and product names mentioned in this manual are trademarks or registered trademarks of their respective owners.
JAI A-S cannot be held responsible for any technical or typographical errors and reserves the right to make changes to products and documentation without prior notification.

JAI A-S, Denmark
Phone +45 4457 8888
Fax +45 4491 8880
www.jai.com

JAI UK Ltd, England
Phone +44 0 1895 821 481
Fax +44 0 1895 824 433
www.jai.com

JAI Corporation, Japan
Phone +81 45 440 0154
Fax +81 45 440 0166
www.jai-corp.co.jp

JAI Pulnix Inc, USA
Phone (Toll-Free) +1 877 4445 5444
Phone +1 408 747 0300
Fax +1 408 747 0880
www.jaipulnix.com



THE MECHADEMIC COMPANY