



DSP Color CCD Cameras

CV-S3200/3300

Operation Manual

(Rev.B)

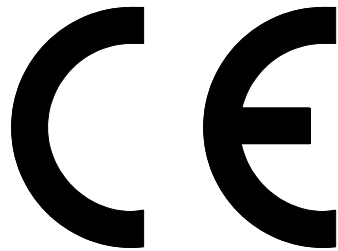

DECLARATION OF CONFORMITY

AS DEFINED BY THE COUNCIL DIRECTIVE

89/336/EEC
EMC (ELECTROMAGNETIC COMPATIBILITY)

WE HEREWITH DECLARE THAT THIS PRODUCT
COMPLIES WITH THE FOLLOWING PROVISIONS APPLYING TO IT.

EN-50081-1

EN-50082-1

Table of Contents

CE declaration	2
1. General	4
2. Main features	4
3. Standard composition	5
4. Pin assignment	5
5. Functions and operations	6
5.1 SW1 switch on PK8167 board	6
5.2 On-screen-menu	7
5.3 RS 232C functions	11
6. External appearance	12
7. Specifications	13
8. Appendix	14
8.1 Precautions	14
8.2 Typical CCD Characteristics	14
8.3 References	14
9. Users Record	15

1. General

The CV-S3200/3300 is a new high-resolution color camera series, available in PAL or NTSC format. The camera series was developed with JAI's new DSP processor, which has remarkable high signal to noise ratio as well as a high bit flow. The cameras also have built-in RAM, which together with the DSP enables the camera to produce field integration with 100% horizontal resolution.

The CV-S3200/3300 series features EXview HAD™ sensors (CV-S3200:1/2" and CV-S3300:1/3") which are extra light sensitive and have enhanced anti-smear and blooming characteristics.

The cameras run on 12V DC and can be gen-locked or use VBS for external synchronization. There are connections for video control or direct drive lens, and VBS and Y/C video outputs. Both cameras have CS/C-mount with a variable mounting ring for back focus. The CV-S3300 has screw terminals for power, gen-lock and line-lock. The CV-S3200 comes with D-sub connector.

The camera set-up can be performed via the JAI software platform and an RS232C port, or from a new on-screen menu that can be controlled by the three buttons mounted on the rear of the camera. Both the software and the on-screen-menu can control the following setting: shutter, integration, gamma, AGC, H/V enhancer, iris-level for direct drive, positive/negative picture, back-light compensation, and AWB fixed or manual color temperature.

Applications include surveillance, security, medical and a large variety of other industrial applications.

2. Main Features

- 1/2" EXview HAD™ IT color CCD sensor for CV-S3200, 1/3" EXview HAD™ IT color CCD sensor for CV-S3300
- NTSC : 768 (h) x 494 (v) , PAL : 752 (h) x 582 (v)
- 450 TV lines horizontal resolution
- Composite VBS and Y/C output
- Excellent color reproduction
- Field integration mode for higher sensitivity
- S/N ratio > 50 dB
- White balance automatic or manual
- Auto iris and CCD iris for light regulation
- Manual shutter up to 1/10,000 sec.
- Scanning reversal function (mirror-effect mode)
- CS-lens mount with focus adjustment
- CV-S3200 employs 9 pin Dsub connector at camera rear panel for single cable solution.
- CV-S3300 provides 7 pin terminal at camera rear panel for easy cable installation.

3. Standard compositions

- | | | |
|----|-----------------------------------|-----|
| 1) | Camera main body | x 1 |
| 2) | C-mount adaptor (MP-55) | x 1 |
| 3) | Auto iris lens pulg (E4-191J-100) | x 1 |
| 4) | Y/C out plug (TCP8040-01-520) | x 1 |
| 5) | Operation manual | x 1 |

4. Pin assignment

4-1. DC IN/SYNC/RS-232C connector

a) 9 pin D-sub connector for CV-S3200

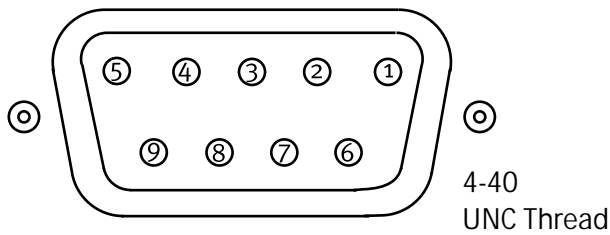

- 1 : Ground
- 2 : +12V DC input
- 3 : Ground
- 4 : VBS output
- 5 : Sync input
- 6 : Y output
- 7 : C output
- 8 : TXD output
- 9 : RXD input

b) 7 pin terminal for CV-S3300

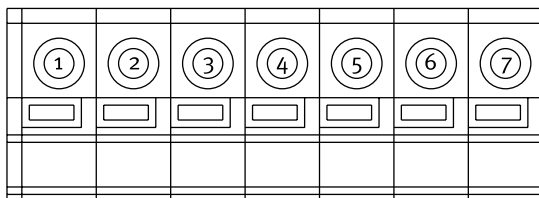

- 1 : RXD input
- 2 : TXD output
- 3 : Ground
- 4 : Sync. input
- 5 : Ground
- 6 : +12V DC input
- 7 : Ground

4-2. S-VIDEO connector

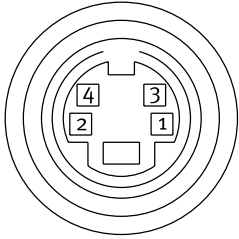

- 1 : Ground
- 2 : Ground
- 3 : Y output
- 4 : C output

4-3. LENS connector

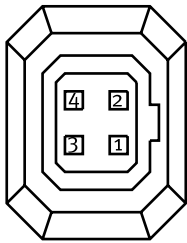

- 1 : +9V / Damp-
- 2 : NC / Damp+
- 3 : Iris / Drive+
- 4 : Ground / Drive-

5. Functions and operations

5-1. SW1 switch on PK8167 board

This switch is to select the type of auto iris. It is located on the CCD board (PK8167), as below.

- Up : Direct drive mode (Passive)
- Down : Video controlled (Active)

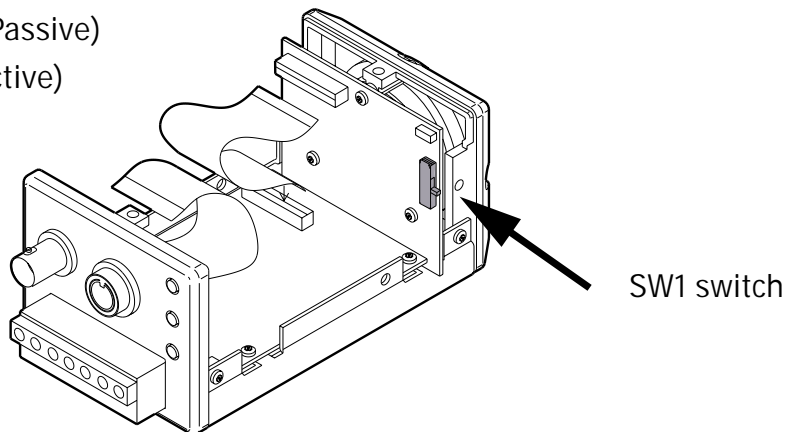

Note : Factory pre-set is Video controlled.

5-2. On-screen-menu

On-screen-menu can be controlled by the "UP", "DOWN" and "FUNC" switches on the rear panel.

5-2-1. Functions

The following functions are adjustable at on-screen-menu.

- White balance
- Shutter
- Gain
- Back light compensation
- Lens iris
- Gamma
- Scanning reversal
- Sensitive (Field integration)

a) White balance

This function is to adjust the color temperature to make the color of the image correct.

3200 K : For incandescent lamp or halogen lamp.

4600 K : For white fluorescent lamp.

5600 K : For daylight.

Auto : The TTL system is employed for auto white balance, and it detects the highest video level in objects to recognize a white color. It is necessary to place the camera in a position where the camera does not pick up spot lights and fluorescentlights.

Manual : To adjust the color temperature between 2700 K to 6700 K.

One push : Refer to 5-2-2 (d).

Note : Factory pre-set is auto white balance.

b) Shutter

This function is used for “freezing” objects and for light regulations. Nine exposure time settings are available.

OFF : 1/60 sec. (NTSC), 1/50 sec. (PAL)

Selectable shutter : 1/125, 1/250, 1/500, 1/1000, 1/2000, 1/4000, 1/10,000 sec.

Flicker-less : 1/100 sec. (NTSC), 1/120 sec. (PAL)

CCD iris : Shutter speed changes automatically.
(1/60 sec. to 1/10000 sec. (NTSC), 1/50 sec. to 1/10,000 sec.(PAL))

Note : Factory pre-set is OFF.

CAUTION

1. Under certain unique light conditions, the following may appear.
 - Strong smear and/or blooming on highlighted objects.
 - Noticeable flicker in the picture.
2. CCD iris
Continuous variable electronic shutter controls the exposure time of the CCD sensor, depending on the incoming light level. When this mode is selected, auto or manual iris lens can be used instead of an auto iris lens.
3. Shutter speed and sensitive mode
In sensitive mode the CCD iris does not function.

c) AGC (Auto gain control)

OFF : Gain is fixed at minimum 0 dB

+12 dB : AGC ON (0 to +12 dB)

+24 dB : AGC ON (0 to +24 dB)

Manual : Manual gain

Note : Factory pre-set is AGC OFF.

CAUTION

1. Auto iris lens can be used only when the CCD iris is OFF.

d) BLC (Back Light Compensation)

BLC circuit will compensate for extreme highlights in the field of view.

There are three pre-defined patterns that can be selected. These are shown below. The higher the value, the more backlight compensation.

Patten 1

1	1	
4	9	4
1	1	

Patten 2

0	0	
0	15	0
0	0	

Patten 3

0	0	
0	10	0
4	4	

Note : Factory pre-set is OFF.

CAUTION

- The BLC works under the following conditions:

BLC	○	○	○	×
AGC	ON	ON	OFF	OFF
CCD iris	ON	OFF	ON	OFF

○ : Effective
 × : Not-effective

- It is recommended to switch "BLC OFF" when using the camera with pan/tilt head or if the scene illumination changes rapidly.
- With "BLC ON" the regulation speed of the iris is decreased.

e) Iris level

This is to set the video level, when the camera is set at CCD iris, AGC ON and auto iris.

f) Gamma

This function is to set the gamma correction.

- 0.45 : Correction
- 0.6 : Correction
- 1.0 : Linear

Note : Factory pre-set is 0.45.

g) Scanning reversal (mirror-effect mode)

This function can change the horizontal scanning between normal and reverse.

- OFF : Normal scanning
- ON : Reversal scanning

Note : Factory pre-set is set at OFF.

h) Field integration

The sensitivity can be set at these pre-set positions.

- OFF : Standard sensitivity (Exposure time = 1 field)
- 2F : 2 times higher than standard sensitivity (Exposure time = 2 fields)
- 4F : 4 times higher than standard sensitivity (Exposure time = 4 fields)
- 8F : 8 times higher than standard sensitivity (Exposure time = 8 fields)
- 16F : 16 times higher than standard sensitivity (Exposure time = 16 fields)
- 32F : 32 times higher than standard sensitivity (Exposure time = 32 fields)
- 64F : 64 times higher than standard sensitivity (Exposure time = 64 fields)

Note : Factory pre-set is OFF.

5-2-2. Operations

Screen display (example)

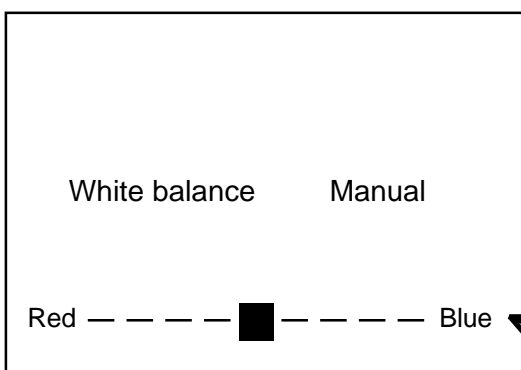

Function buttons for on-screen-menu

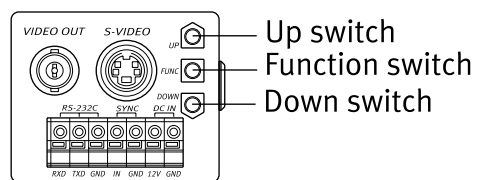

Rear panel of CV-S3300 (example)

Note : This scroll bar will be displayed when the following functions are selected.

White balance = manual, AGC = manual, Iris = manual

- (a) To start adjustment, push the "FUNC" button. The menu will appear on the monitor .
(See page 12)
- (b) Use "UP" or "DOWN" buttons to choose functions. To select function, press the "FUNC" button.
- (c) After selecting the function, press "UP" or "DOWN" buttons to choose mode. To select mode, press the "FUNC" button.
- (d) To use One Push White Balance.

Go to the next function if needed, and repeat (b) to (c).

1. Change to White Balance mode by Function SW.
2. Change to One-push mode by Up or Down SW.
3. Push Function SW and make it READY.
4. Push Up SW, and One-Push White Balance function starts.
5. Push Function SW to save the data (R.B.Gain) of One-Push White Balance.

If you turn off the power without saving the data, it will return to the original status.

5-3. RS 232C functions

- a) White balance : To adjust the color temperature
- b) Electronic shutter : To adjust the shutter speed
- c) Auto gain control : OFF, +12dB, +24dB, manual selectable
- d) Back light compensation : To create your own BLC pattern.
- e) Iris level : To adjust the video level
- f) Gamma : 0.45, 0.60, 1.0 selectable
- g) Scanning reversal : To select the scanning direction
- h) Frame integration : To select the sensitivity

CV-S3200/3300

6. External appearance

Unit : mm (inches)

e.g. CV-S3200

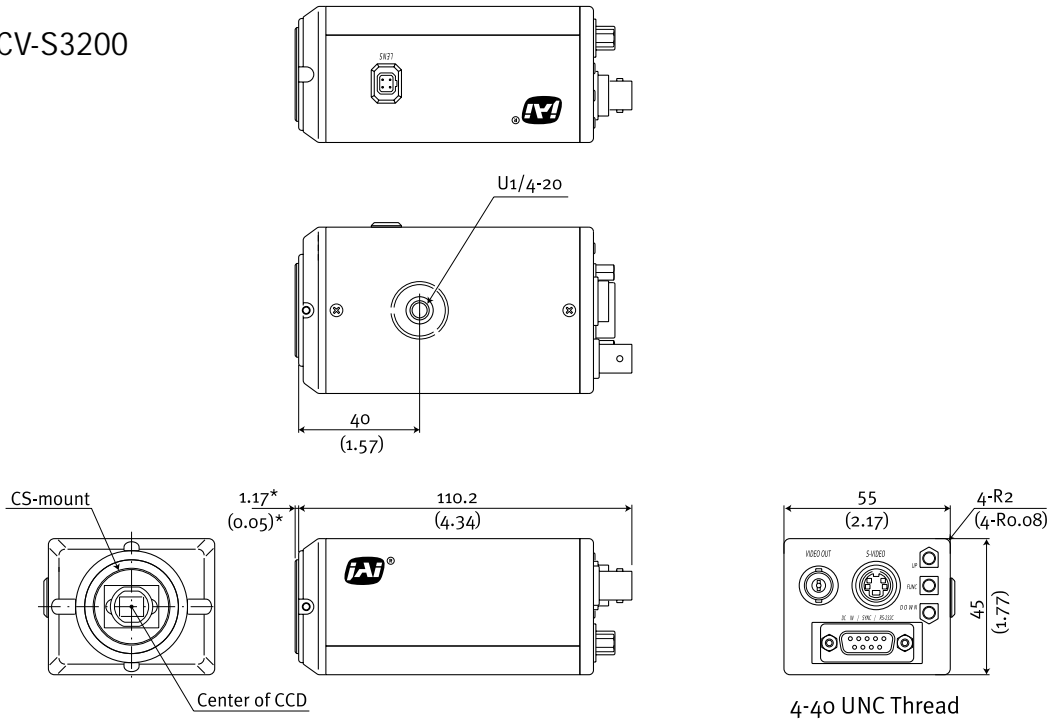

e.g. CV-S3300

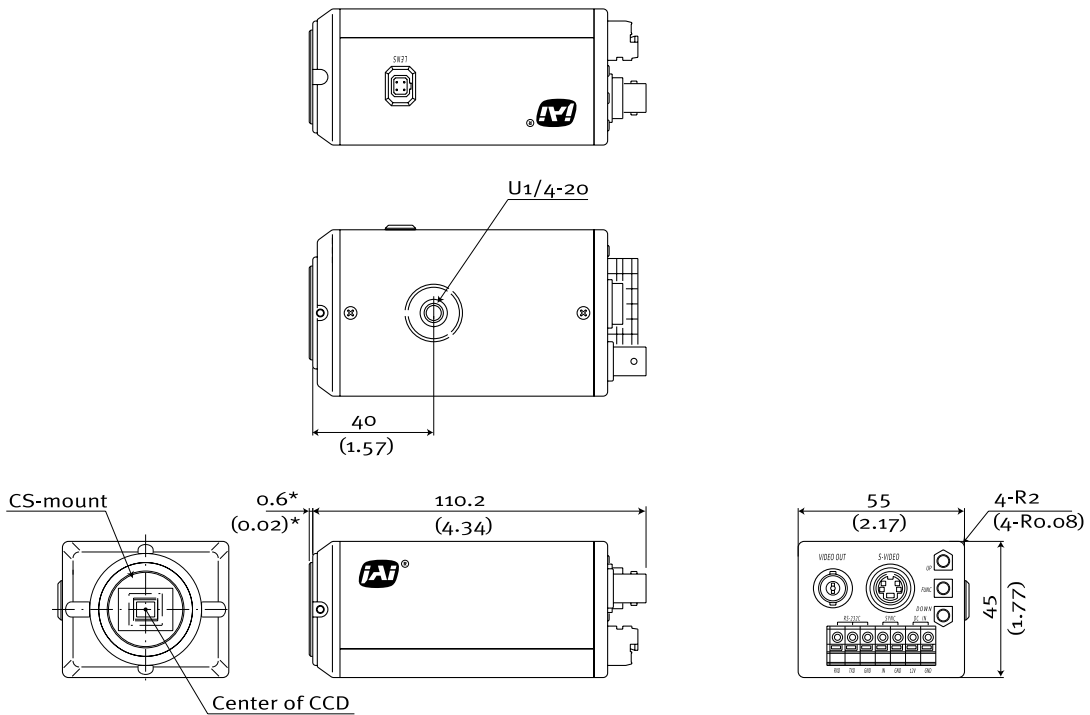

CV-S3200/3300

7. Specifications

Model name	CV-S3200	CV-S3300
TV standard	NTSC / PAL	NTSC / PAL
Scanning system	NTSC : 525 lines, 30 frames/sec. PAL : 625 lines, 25 frames/sec.	
CCD sensor	Color 1/2" IT CCD sensor	Color 1/3" IT CCD sensor
Effective pixels	NTSC : 768 (h) x 494 (v) PAL : 752 (h) x 582 (v)	
Cell size	NTSC : 8.4 (h) x 9.8 (v) μm PAL : 8.6 (h) x 8.3 (v) μm	NTSC : 6.35 (h) x 7.4 (v) μm PAL : 6.3 (h) x 6.25 (v) μm
Resolution (horizontal)	450 TV line	
Sensitivity	0.4 lux on sensor (AGC ON, 50% video)	
S/N ratio	>50 dB (AGC OFF, Gamma=1.0)	
Video output	VBS 1.0 Vpp at 75 Ohm Y/C output 1.0 Vpp at 75 Ohm	
Gain	Off, +12 dB, +24 dB, manual	
White balance	3200K, 4600K, 5600K, auto, manual, one push	
Gamma	1.0 - 0.6 - 0.45	
Synchronization	Internal / external sync. or VBS 1.0 Vpp	
Shutter	OFF (1/60 at NTSC, 1/50 at PAL), 1/125, 1/250, 1/500, 1/1000, 1/2000, 1/4000, 1/10,000, CCD iris, Flicker-less (NTSC : 1/100, PAL : 1/120)	
Field integration	Off, 2F~64F	
Back light compensation	Off, pattern 1, pattern 2, pattern 3	
Scanning reversal	Off, On	
Serial interface	RS 232C	
Rs 232C functions	Electronic shutter, CCD iris, Flicker-less, White balance, Back light compensation, Video reversal, Gamma, Gain, Chroma	
Operating environment	Temperature : -5°C to + 45°C Humidity : 20% to 80% non-condensing	
Power	+12 VDC \pm 10%, 3.0W	
Lens mount	CS-mount	
Dimensions	45 x 55 x 110.2 (HxWxD) mm	
Weight	350 g approx.	

Note : Above specifications are subject to change without notice.

8. Appendix

8-1 Precautions

Personnel not trained in dealing with similar electronic devices should not service this camera.

The camera contains components sensitive to electrostatic discharge. The handling of these devices should follow the requirements of electrostatic sensitive components.

Do not attempt to disassemble this camera.

Do not expose this camera to rain or moisture.

Do not face this camera towards the sun, extreme bright light or light reflecting objects. When this camera is not in use, put the supplied lens cap on the lens mount.

Handle this camera with the maximum care. Operate this camera only from the type of power source indicated on the camera.

Power off the camera during any modification such as changes of jumper and switch setting.

8.2 Typical CCD Characteristics

The following effects may be observed on the video monitor screen. They do not indicate any fault of the CCD camera, but do associate with typical CCD characteristics.

V. Smear

Due to an excessive bright object such as electric lighting, sun or strong reflection, vertical smear may be visible on the video monitor screen. This phenomenon is related to the characteristics of the Interline Transfer System employed in the CCD.

V. Aliasing

When the CCD camera captures stripes, straight lines or similar sharp patterns, jagged image on the monitor may appear.

Blemishes

Some pixel defects can occur, but this does not have an effect on the practical operation.

Patterned Noise

When the CCD camera captures a dark object at high temperature or is used for long time integration, fixed pattern noise (shown as white dots) may appear on the video monitor screen.

8.3 References

1. This manual and datasheet for CV-S3200/3300 can be downloaded from www.jai.com
2. Camera control software can be downloaded from www.jai.com

9. User's Record

Camera type: CV-S3200/3300

Revision: (Revision B)

Serial No.

Users Mode Settings

Users Modifications

2700-21107 E B1 0701

JAI A-S, Denmark
Produktionsvej 1, 2600 Glostrup
Copenhagen, Denmark
Phone +45 4457 8888
Fax +45 4491 8880
www.jai.com

JAI Corporation, Japan
German Industry Center
1-18-2 Hakusan, Midori-ku
Yokohama,
Kanagawa 226-0006, Japan
Phone +81 45 933 5400
Fax +81 45 931 6142
www.jai-corp.co.jp

JAI America, Inc., USA
Suite 450
23046 Avenida de la Carlota
Laguna Hills, CA 92653
USA
Phone +1 949 472 5900
Fax +1 949 472 5908
www.jai.com



THE MECHADEMIC COMPANY