



TM-200/TM-300

Miniature CCD Camera

Operation Manual



Notice

The material contained in this manual consists of information that is proprietary to PULNiX America, Inc., and may only be used by the purchasers of the product. PULNiX America, Inc. makes no warranty for the use of its product and assumes no responsibility for any errors which may appear or for damages resulting from the use of the information contained herein. PULNiX America, Inc. reserves the right to make changes without notice.

Warranty

All of our solid state cameras have a full three year warranty. If any such product proves defective during this warranty period, PULNiX America, Inc. will repair the defective product without charge for parts and labor or will provide a replacement in exchange for the defective product. This warranty shall not apply to any damage, defect or failure caused by improper use or inadequate maintenance and use.

Certifications

UL

CE

FCC

This equipment has been tested and found to comply with the limits for a Class A digital device, pursuant to Part 15 of the FCC Rules. These limits are designed to provide reasonable protection against harmful interference when the equipment is operated in a commercial environment. This equipment generates, uses and can radiate radio frequency energy and, if not installed and used in accordance with the instruction manual, may cause harmful interference to radio communications. Operation of this equipment in a residential area is likely to cause harmful interference in which case the user will be required to correct the interference at his own expense.

WARNING

Changes or modifications to this unit not expressly approved by the party responsible for FCC compliance could void the user's authority to operate the equipment.

TM-200 Operation Manual
Printing: June 1998

PULNiX America, Inc.
1330 Orleans Drive
Sunnyvale, CA 94089
Tel: (408) 747-0300
Tel: (800) 445-5444
Fax: (408) 747-0880

1	INTRODUCTION	1
1.1	Product Description	1
1.2	Features	1
1.3	Functional Options	2
1.4	Applications	3
1.5	System Configuration	3
2	INSTALLATION	4
2.1	Getting Started	4
2.1.1	Unpacking Instructions	4
2.1.2	Components List	4
2.1.3	Accessories	4
2.2	Camera Setup	5
2.2.1	Connector Pin Configurations	5
2.2.2	Power Supply and Power Cable Setup	5
2.2.3	Attaching the Video Output	7
2.2.4	Attaching the Camera Lens	7
2.2.5	Back Focusing the Lens	7
2.2.6	Auto-Iris Lens Setup	7
2.2.7	Monitor Display Mode	7
2.2.8	Connectors and Cables	8
3	OPERATION	9
3.1	Modes of Operation	9
3.1.1	External Switches	9
3.1.2	Shutter Control	9
3.1.3	Field and Frame Modes	9
3.1.4	Integration	10
3.1.5	External Sync	10
3.1.6	Timing	11
3.1.7	Interfacing to Frame Grabbers	12
3.1.8	Sync Output and Clock Output	12
3.2	Board Layout and Adjustment	12
3.2.1	Processor Board	12
3.2.2	Mother Board	12
4	TROUBLESHOOTING	14
4.1	Problems and Solutions	14
4.1.1	Symptom: No Video	14
4.1.2	Symptom: Dark Video	14
4.1.3	Symptom: Non-synchronized Video	14
4.2	Information and Support Resources	15
5	APPENDIX	16
5.1	Specifications	16

5.1.1	Product Specifications	16
5.1.2	Physical Dimensions	17
5.1.3	Glass Specifications	17
5.1.4	C-Mount Specifications	17
5.1.5	Front End Detail	19
5.2	Spectral Response	20

FIGURE 1.	TM-200 System Configuration	3
FIGURE 2.	12P-02 Interface Cable (optional)	6
FIGURE 3.	TM-200 Rear Panel	9
FIGURE 4.	Shutter Control Settings	9
FIGURE 5.	Input Signals	11
FIGURE 6.	TM-200/TM-300 Timing Chart	11
FIGURE 7.	Processor Board	12
FIGURE 8.	Physical Dimensions	17
FIGURE 9.	Camera Front End - Glass Specifications	17
FIGURE 10.	C-Mount	17
FIGURE 11.	Combination With “CS-Mount” Camera	18
FIGURE 12.	Front End Detail	19
FIGURE 13.	Front End Assembly	19
FIGURE 14.	Spectral Response	20

TM-200 / TM-300 Miniature CCD Camera

Operations Manual

1 INTRODUCTION

1.1 Product Description

The TM-200/300 is designed to be a simple yet high quality camera capable of meeting a variety of application requirements. Featuring an advanced Had-type interline transfer 1/2" CCD imager, this miniaturized high resolution camera offers many standard and optional features at a very affordable price. It is available in both EIA (TM-200) and CCIR (TM-300) formats.

1.2 Features

- **Variable electronic shutter and random CCD integration.**

The substrate drain-type shutter mechanism provides a superb picture at various speeds without smearing. The electronic shutter rate can be externally adjusted, from 1/60 to 1/10,000 in discrete steps, via a manually controlled dial switch.

- **Miniaturized and lightweight.**

The use of a CCD image sensor in the video camera module and the development of special mini C-mount lenses makes it possible to produce a very compact, lightweight and robust camera small enough to operate just like a remoted head.

- **High sensitivity.**

The TM-200/TM-300 camera is one of the most low light sensitive 1/2" CCD cameras available today. This feature is especially important when using the faster shutter speeds. The CCD detects images into the near infrared. It requires only 1.0 lux of minimum illumination and 0.5 lux minimum illumination at maximum gain. In general, this allows use of a higher lens f-value while providing greater depth of field and sharper images.

- **Precise image geometry.**

On the CCD image sensor, the photosensor elements form exact rows both horizontally and vertically so that a very precise image geometry may be obtained.

- **Low lag/high resistance to image burning.**

Since the CCD is highly resistant to image burning, the camera may be exposed to bright objects for a long period of time. Because a “smear” phenomena may occur when shooting a very bright object, an infrared cutoff filter is recommended to obtain a clear picture.

- **AGC selection, manual gain control and gamma adjustment.**

These adjustments, which are particularly important in vision system applications, are externally adjustable via switches on the rear plate.

- **Genlock circuit.**

A genlock circuit is built in to accept external sync for applications in which external sync is required.

- **High resistance to magnetic field and vibration/mechanical shock.**

Due to its ruggedized design, the CCD imager can withstand strong vibration and shock with little or no noise appearing in the picture. Since the TM-200/TM-300 is not influenced by a magnetic field, it will produce stable images even when placed next to objects such as electric furnaces, welding machines or NMR scanners.

- **Quick start-up and low power consumption.**

No more than 2 seconds is needed for the TM-200/TM-300 to warm up, and shooting can begin within a second after turning on the camera. The power consumption is only 3.0W. This makes the camera excellent for use with battery operated systems.

- **Three Year Warranty**

The CCD solid state image sensor allows the camera to maintain a superior performance level indefinitely while requiring virtually no maintenance. PULNiX backs all of the TM Series cameras with a three-year warranty.

Warning: Unscrewing the camera cover or opening the camera in any way will void this warranty.

1.3 Functional Options

- Internal IR Cut Filter (OP3-1)
- Optical Filter Removal (OP3-2)
- Pixel Clock Output (OP7-2)
- Glassless CCD Imager (OP21)
- DC Coupled (OP72)

1.4 Applications

The miniature size of the TM-200/TM-300 camera eliminates the need for a remoted imager camera in all but the most confined spaces. This camera fits easily, both physically and functionally, into all types of machine vision, automated inspection, and related applications. Other uses include remotely piloted vehicles, miniature inspection devices, surveillance, microscopes and medical equipment.

1.5 System Configuration

Figure 1 (below) presents a typical system configuration in which a computer and frame grabber board are used. A computer and frame grabber board are not required for operation of the TM-200/TM-300 camera.

FIGURE 1.

TM-200 System Configuration

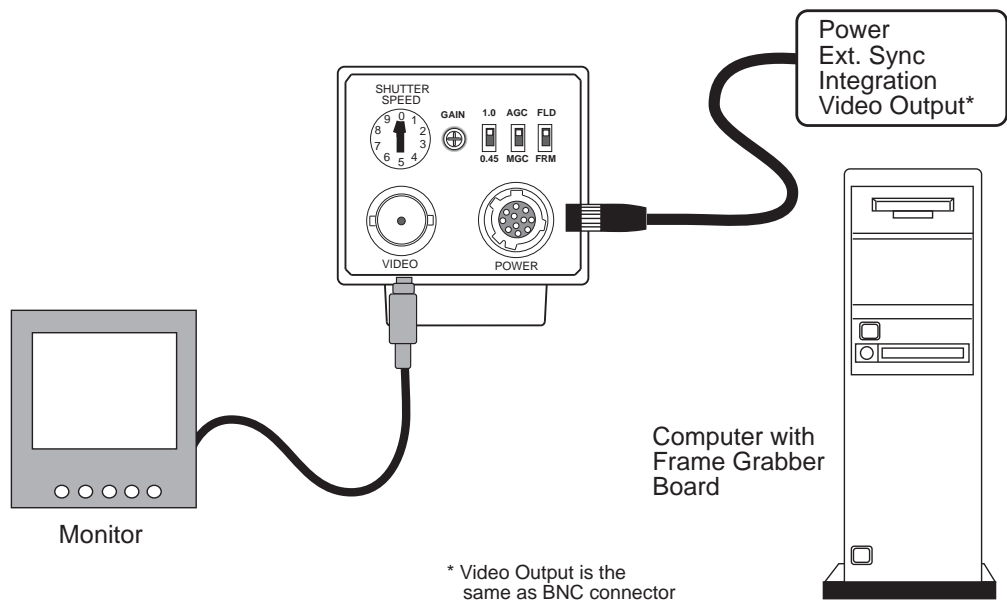

2 INSTALLATION

The following instructions are provided to help you to set up your video camera system quickly and easily. It is suggested that you read through these instructions prior to unpacking and setting up your camera system

2.1 Getting Started

2.1.1 Unpacking Instructions

It is recommended that the original packing cartons for the cameras and lenses be saved in case there is a need to return or exchange an item.

It is also recommended that any equipment being sent to another location for field installation be bench tested to assure that everything is fully operational as a system.

2.1.2 Components List

Please begin by checking your order against the Components List (below) to assure that you have received everything as ordered, and that nothing has been overlooked in the packing materials. If any item is missing, please contact your PULNiX representative immediately.

- TM-200 camera
- TM-200 data sheet
- TM-200 operations manual

2.1.3 Accessories

Following is a list of additional accessories or equipment that may be recommended or required for your particular application. Please check with your PULNiX representative prior to the installation of your video system to determine what you might need.

- Power Cable: 12P-02 Interface Cable
- Power Supply: PD-12P, PD-12P, DC-12N, or K25-12V

2.2 Camera Setup

2.2.1 Connector Pin Configurations

2.2.1 (a) 12-Pin Connector

The TM-200 has a 12-pin connector for power input. Generally, Pin #1 is Ground and Pin #2 is +12V DC. The other pins handle a number of other input and output functions, which will be discussed further in other sections.

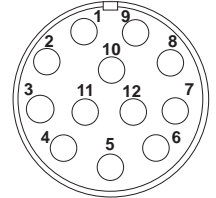

Pin	Description	Pin	Description
1	GND	7	VD Input
2	+12V DC	8	GND
3	GND	9	HD Input
4	Video Out	10	N/C
5	GND	11	Integration
6	N/C	12	N/C

2.2.2 Power Supply and Power Cable Setup

2.2.2 (a) Power Supplies

PULNiX recommends the following power supplies:

K25-12	110V AC/12V DC	2.1A power supply
P-15-12	220V AC/12V DC	2.1A power supply
K50-12	110V AC/12V DC	4.2A power supply
PD-12P	110V AC/12V DC	0.5A power supply

For users providing power through the 12-pin connector, the PD-12P power supply is available with the 12-pin mating connector already attached to the leads from the power supply. The PD-12 power supply can be connected to the PULNiX power cable via a terminal strip or directly.

When wiring the PD-12 power supply directly, please note the following:

- Twist the lead ends together and tin solder for strength and electrical continuity.
- Use shrink tubing or a similar insulator to prevent exposed leads from touching.
- The +12V lead is marked with a red stripe or white lettering; be sure not to reverse the leads.
- Properly insulate all connections to prevent shorting.

2.2.2 (b) PULNiX Power Cables

If you are using PULNiX power cables, such as the 12P-02, KC-10, etc., please refer to the pin-out diagram. The color coded leads use Grey for Ground and Yellow for +12V DC.

FIGURE 2.

12P-02 Interface Cable (optional)

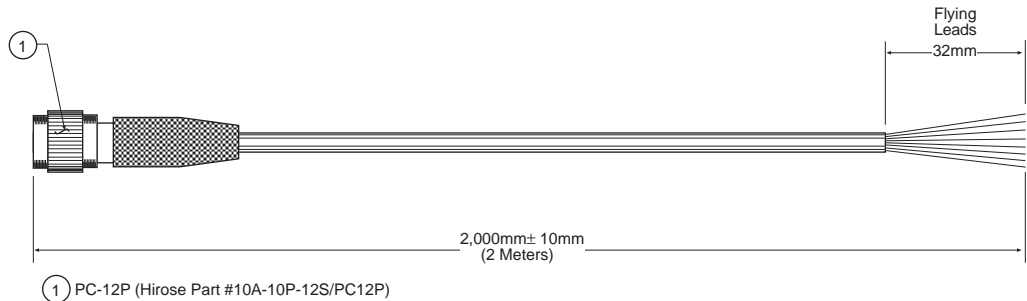

12P-02 Interface Cable

Pin#	Lead Color	Function	Pin#	Lead Color	Function
1	Gray	GND	7	Black coax	VD Input
2	Yellow	+12VCD	8	White coax shield	GND
3	Red coax shield	GND	9	White coax	HD Input
4	Red coax	Video	10	Brown	N/C
5	Orange coax shield	GND	11	Blue	Integration
6	Orange coax	N/C	12	Black coax shield	N/C

Note: Make sure that the unused leads are not touching and that there is no possibility that the leads could short due to exposed wires.

2.2.2 (c) “K” Series Power Supplies

Attach the 110V line cord to the two terminals marked “AC”. Do not plug the cord into a 110V AC socket until later in the procedure. Next, attach the Grey and Yellow leads of the power cable to the Ground and 12V DC terminals respectively. Be sure to replace the plastic terminal guard on the power supply at this time.

Note: The “K” series power supplies are designed primarily for OEM users who will be mounting the power supply inside a protective enclosure. For use in exposed situations, the DC-12N and PD-12 are recommended.

2.2.2 (d) Building Your Own Power Cable

Consult the pin-out for the camera purchased. Connect the Ground and +12V power leads of the PC-12P power connector to Pin #1 and Pin #2, respectively (power must be DC regulated, and of sufficient current to properly power the camera).

2.2.2 (e) Attaching the Power Cable to the Connector

The 12-pin connector is keyed and will only fit in one orientation. Rotate the connector while applying slight pressure until the keyways line up. Press the connector into place until firmly seated.

The power cord may now be plugged into the 100V AC socket, and the camera powered up.

2.2.3 Attaching the Video Output

Most users utilize the BNC connector for video output from the camera. Connect the output from the camera to the input of your monitor, VCR or switching device. The input of the monitor should be balanced for 75 Ω termination. Standard RG-59 type coaxial cable should carry a full video signal for up to 500 feet.

Users wishing to output the video and input the power and sync to a camera over a single cable can use the PULNiX multi-conductor cables, such as the 12P-02, the KC-10, etc. The mini coaxial leads in PULNiX multi-conductor cables are designed for short runs of no longer than 100 feet.

Note: Make sure that no extraneous wires are visible which could cause a short.

2.2.4 Attaching the Camera Lens

The TM-200/TM-300 camera accepts 1/2" or larger format size C-mount lenses. To attach the C-mount lens to the camera, carefully engage the threads and rotate the lens clockwise until it firmly seats on the mounting ring. Do not force the lens if it does not seat properly. Please note that some lenses with extremely long flangebacks may exceed the mounting depth of the camera.

2.2.5 Back Focusing the Lens

To backfocus the TM-200 camera, first attach a C-mount lens in the lens mount. Be sure that the lens is properly mounted.

Set the lens focus to infinity (if the lens is a manual iris, set the iris to a high f-stop while still retaining a well-illuminated image). Obtain the best focus possible at this setting, then loosen the two miniature hex head set screws locking the focus ring in place. Now turn the entire lens and focus ring assembly back and forth until the best image is obtained. Tighten the focus ring set screws. Your backfocus is now set.

2.2.6 Auto-Iris Lens Setup

Auto-iris lenses with full video input can be used with the PULNiX TM-200, although this camera model does not come equipped with auto-iris output.

Note: Make sure that the power is removed from the camera before connecting or disconnecting the auto-iris lens. There is a small chance that damage could occur to the auto-iris lens by plugging or unplugging it while the camera is powered up.

Power down the camera before installing the auto-iris lens. To install the auto-iris lens in a PULNiX camera for which the auto-iris input is not supplied, wire the signal (video) on the lens into the terminal 1 Vp to peak video output on the camera.

Point the camera at a light area and then quickly towards a darker area. If everything is working properly, the iris should adjust for the light change.

2.2.7 Monitor Display Mode

For monitoring real time video, connect the video output to a video monitor or other device.

2.2.8 Connectors and Cables

12-pin connector and cable: Standard cable is 12P-02 (2m, 8 conductor cable) for power and external controls.

3 OPERATION

3.1 Modes of Operation

3.1.1 External Switches

FIGURE 3.

TM-200 Rear Panel

Gamma switch

Up = 1.0

Down = 0.45

AGC/MGC switch

Up = AGC (Automatic Gain Control)

Down = MGC (Manual Gain Control)

* When MGC is selected, the camera gain is adjustable with the potentiometer on the back plate.

FLD/FRM Switch

Up = FLD (Field Mode)

Down = FRM (Frame Mode)

* Select FRM for strobe applications and FLD for high shutter speed applications.

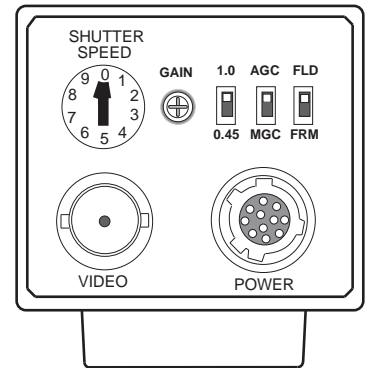

3.1.2 Shutter Control

FIGURE 4.

Shutter Control Settings

Set	Shutter Mode
0	1/60
1	1/125
2	1/250
3	1/500
4	1/1,000
5	1/2,000
6	1/4,000
7	1/10,000
8	N/C
9	N/C

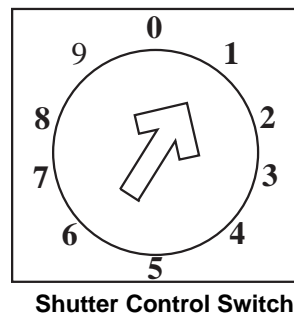

3.1.3 Field and Frame Modes

The standard factory setting for the TM-200/TM-300 camera is FIELD MODE. The mode selection is on the back panel of the camera.

3.1.3 (a) Field Mode

In Field Mode, two horizontal rows are scanned together, changing the pair at each interlace scan. The sensitivity of the CCD is doubled for one field of integration, therefore it can obtain the same sensitivity as in Frame Mode in half the period of time. This is an advantage when the shutter is used often. Because of the alternating two row scanning, Moire is almost unnoticeable. While the vertical resolution is not as good as in Frame Mode, it is sufficient to view the full vertical resolution of the TV format.

Note: Only odd fields are output in this mode. Field Mode cannot provide full frame resolution with strobe lighting applications.

3.1.3 (b) Frame Mode

In Frame Mode, each horizontal row is scanned as interlace scanning. The integration of each pixel is one frame period. Vertical pixel resolution is good, and exact location is obtained. A disadvantage as compared with Field Mode is the tendency to show vertical Moire. For strobe lighting, Frame Mode must be used to achieve full frame resolution.

3.1.4 Integration

The CCD imager of the TM-200/TM-300 can be exposed longer than normal TV timing (16.7 msec.). This feature provides high sensitivity for dark environment applications.

Pin #11 of the 12-pin connector is the control pin for integration. It accepts standard TTL inputs. High is considered 5 Volts and Low is considered 0 Volts. You may enable (i.e., not actually start integrating an image) integration by applying a high signal to pin #11. Then, when a low voltage is applied to the same pin #11, the integration process begins. Integration blocks the transfer gate of the image data out of the CCD array. Think of a transfer gate(sg) as a floodgate that lets water out of a lake (CCD array). Upon returning the signal back to high which is required to end the process, the image is output.

Set the camera in frame mode to output two fields of information. In this mode, the output fields appear to have different exposures, so this may cause problems in some applications. Set to field mode to output one frame with only one frame of resolution, one field is doubled to obtain one frame (this is not a true full frame of information).

3.1.5 External Sync

The TM-200/TM-300 can accept external sync from an external sync generator or frame grabber. Input specifications:

Internal/External auto switch
fH+15.734 KHz \pm 5%, fV +59.95 Hz \pm 5%

Note: The TM-300 has a one (1) horizontal line delay between the input VD signal and the output video. If external vertical drive (VD) is applied to the camera, it may cause the video output to be delayed 1 HD (1 H = \sim 64.0 μ s). If the imaging system is capable of automatically detecting the start of video (within a few HD), then no problem will exist. Otherwise, re-configure the video capturing sequence to delay video acquisition of 1H.

FIGURE 5.

Input Signals

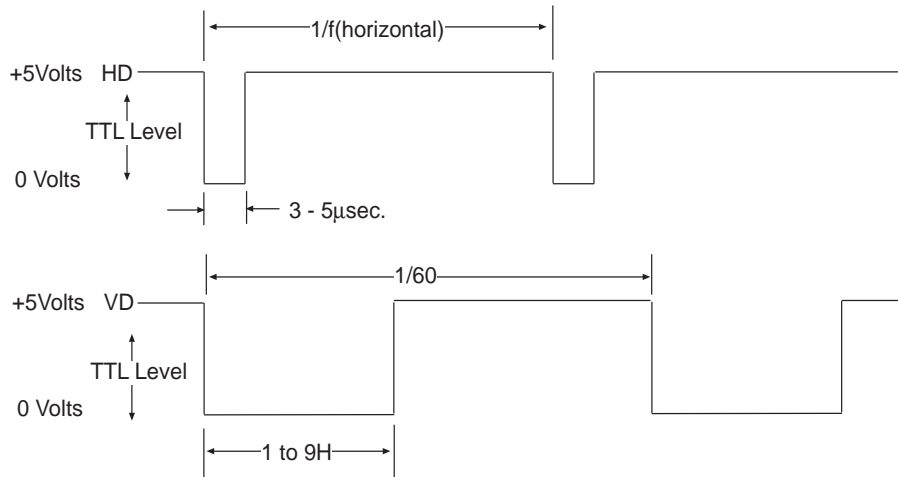

3.1.6 Timing

FIGURE 6.

TM-200/TM-300 Timing Chart

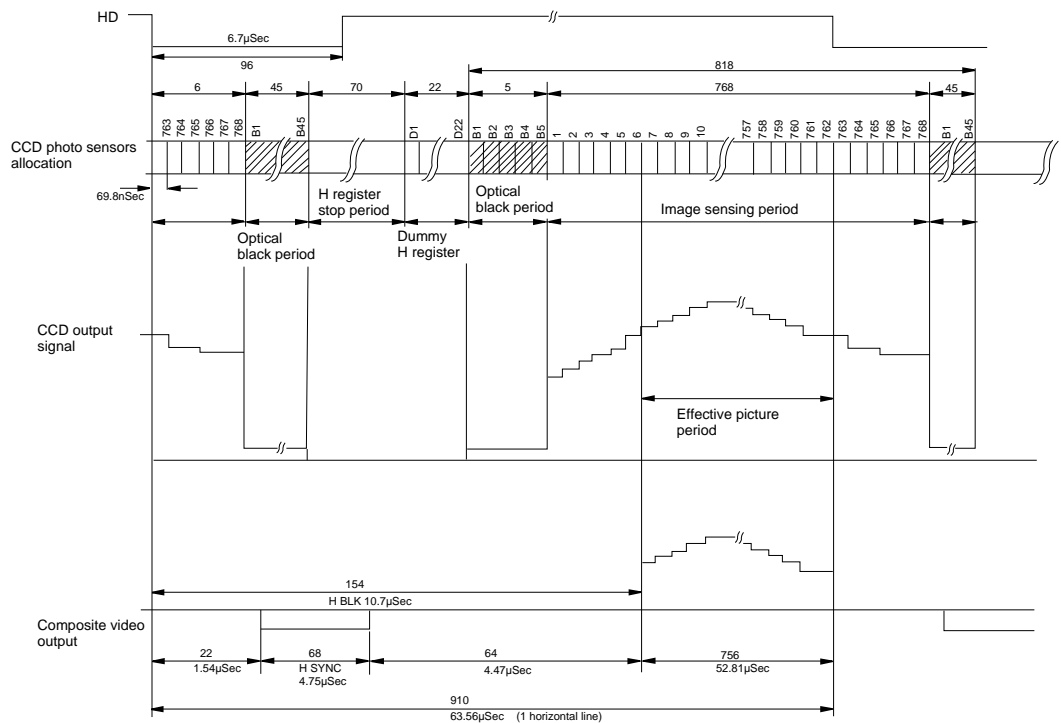

3.1.7 Interfacing to Frame Grabbers

12-pin connector or BNC.

3.1.8 Sync Output and Clock Output

TTL level internal sync and buffered pixel clock output (14.31818MHz) are available from the TM-200/TM-300 camera. The signal is an emitter follower output requiring a termination resistor at the end of the cable. The suggested value is from 75Ω to 330Ω.

3.2 Board Layout and Adjustment

3.2.1 Processor Board

Connect Processor Board to test jig and check all functions.

Voltage Setting

- AGC Adjust VR1 (AGC) so that the pot. is 2.0V.
- MGC Set VR3 (MGC) at mechanical center (2.5V at pot.). Then set ext. gain pot. (rear panel) to 3.6V at pot.

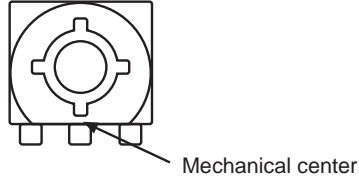

AGC MAX. Adjust VR2 (AGC MAX) to 3.±0.1V at pot.

FIGURE 7.

Processor Board

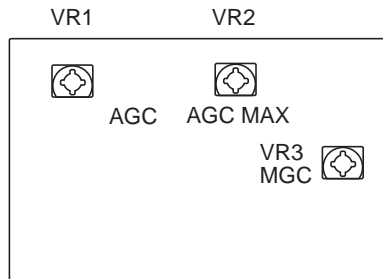

3.2.2 Mother Board

External Sync Specification

Sync	Internal/External auto-switching
HD in	fHD = 15.734 KHz \pm 5% (EIA) fHD = 15.625 KHz \pm 5% (CCIR)
VD in	fVD = 59.94 Hz \pm 5% (EIA) fVD = 50.00 Hz \pm 5% (CCIR)
Input impedance	200 Ω

4 TROUBLESHOOTING

4.1 Problems and Solutions

Following are troubleshooting tips for common problems. Generally, problems can easily be solved by following these instructions. If the following remedies fail to offer a solution to your problems, please contact a PULNiX representative.

4.1.1 Symptom: No Video

Remedies: Check that the following are properly connected and operational.

- Power supplies
- Power cables
- Main power source
- Shutter control
- Async mode
- Lens

4.1.2 Symptom: Dark Video

Remedies: Check that the following are properly connected and operational.

- Shutter selection
- Iris opening on the lens

4.1.3 Symptom: Non-synchronized Video

Remedies: Check that the following are properly connected and operational.

- Proper mode output
- Frame grabber software camera selection

4.2 Information and Support Resources

For further information and support:

Phone: (408) 747-0300
(800) 445.5444
(800) 3-PULNIX (24-hour message access)

Fax: (408) 747-0660

E-mail: pulnixapps@aol.com

Mail: PULNiX America Inc.
Sales Department
1330 Orleans Drive
Sunnyvale, CA 94089
ATTN: Video Applications

Web Site: www.pulnix.com

5 APPENDIX

5.1 Specifications

5.1.1 Product Specifications

TABLE 1. TM-200/TM-300 Product Specifications Table

Model	TM-200 (EIA)	TM-300 (CCIR)
Imager	1/2" Interline transfer CCD, HAD type	
Pixels	768(H) x 494(V)	752(H) x 582(V)
Cell size	8.4µm x 9.8µm	8.6µm x 8.3µm
Scanning	525 lines EIA	625 lines CCIR
Sync	Internal/External auto switch	
	fH=15.734 KHz ±5%, fV=59.95 Hz ±5%	fH=15.725 KHz ±5%, fV=50 Hz ±5%
TV resolution	570(H) x 350(V)	560(H) x 420(V)
S/N Ratio	50dB min., 56dB typical, AGC off	
Min. illumination	0.5 lux (F=1.4)	
Video output	1.0 Vp-p composite video, 75Ω	
AGC	ON/OFF back panel switch	
Gamma	1 or 0.45 back panel switch	
Lens mount	C-mount	
Power requirement	190 mA, 11-15V	
Operating temp.	-10°C to +50°C	
Vibration & Shock	Vibration 7Grms/20-2000 Hz, Shock 70G	
Size	45.8mm x 39.4mm x 66.3mm 1.81" x 1.54" x 2.60"	
Weight	157g (5.6 oz.)	
Power cable	12P-02 (optional)	
Power supply	k25-12V, DC-12N, PD-12	P-15-12
Functional options	3-1, 3-2, 7-2, 21, 25	
Accessories	See current price list.	

5.1.2 Physical Dimensions

FIGURE 8. Physical Dimensions

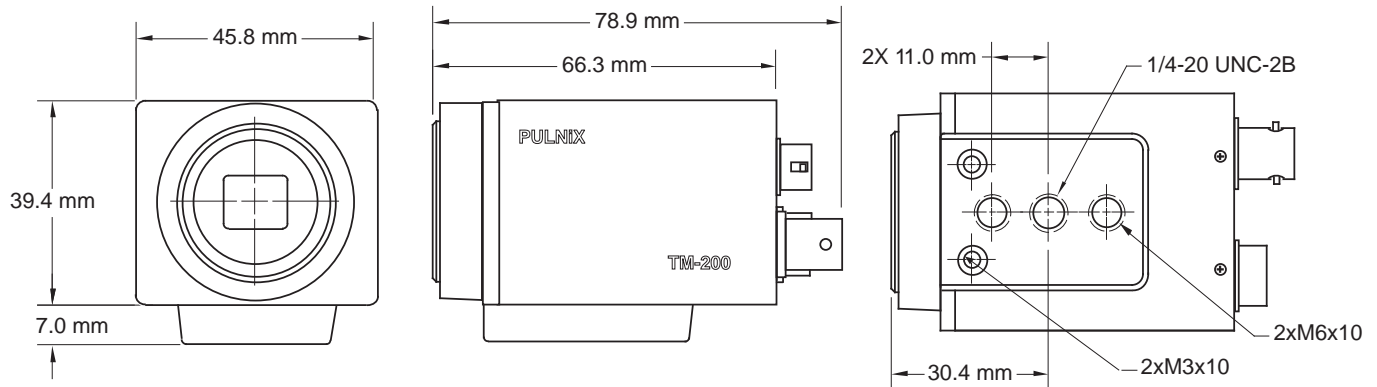

5.1.3 Glass Specifications

FIGURE 9. Camera Front End - Glass Specifications

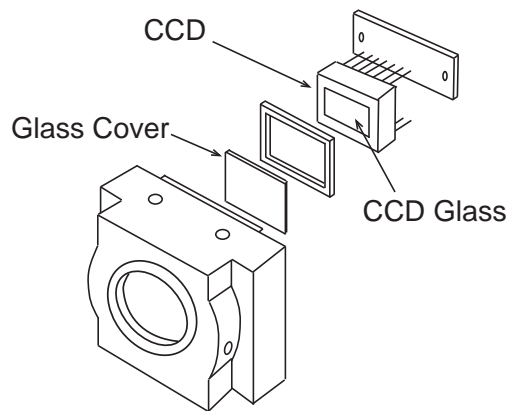

CCD Glass (BK-7) 0.75mm thickness
 Refractive Index = 1.5
 Glass Cover (BD-65) 1.0mm thickness
 Refractive Index = 1.51

5.1.4 C-Mount Specifications

FIGURE 10. C-Mount

The Flange Back Length of the CS-Mount is 12.5mm versus 17.526 of the C-Mount. The shorter Flange Back Length of the “CS-Mount” allows room for the stripe filter incorporated in the color camera. Additionally, the shorter Flange Back Length allows for reduction of the effective diameter of the first lens and reduces the number of lens elements. The common C-Mount lens is completely compatible with a CS-Mount camera when a 5mm extension ring is inserted between the lens and the camera.

FIGURE 11. Combination With “CS-Mount” Camera

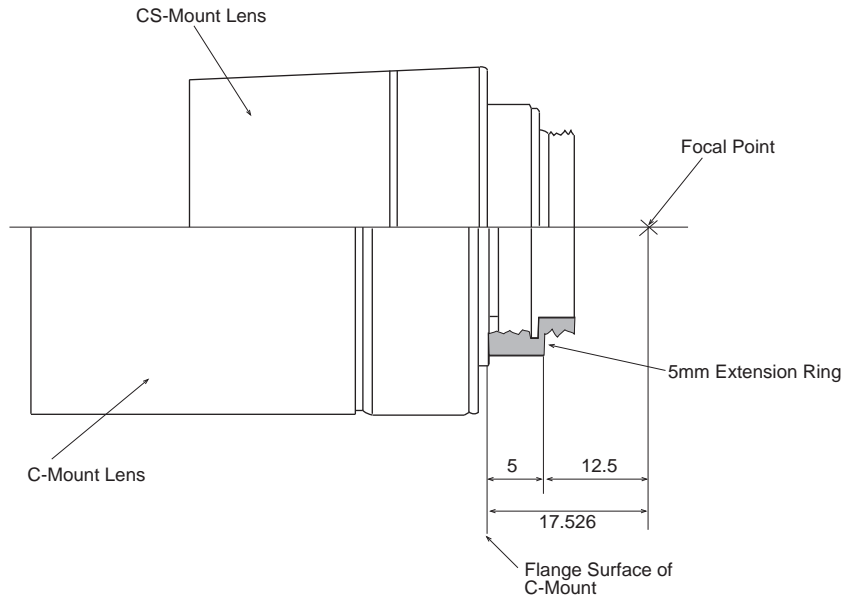

5.1.5 Front End Detail

FIGURE 12.

Front End Detail

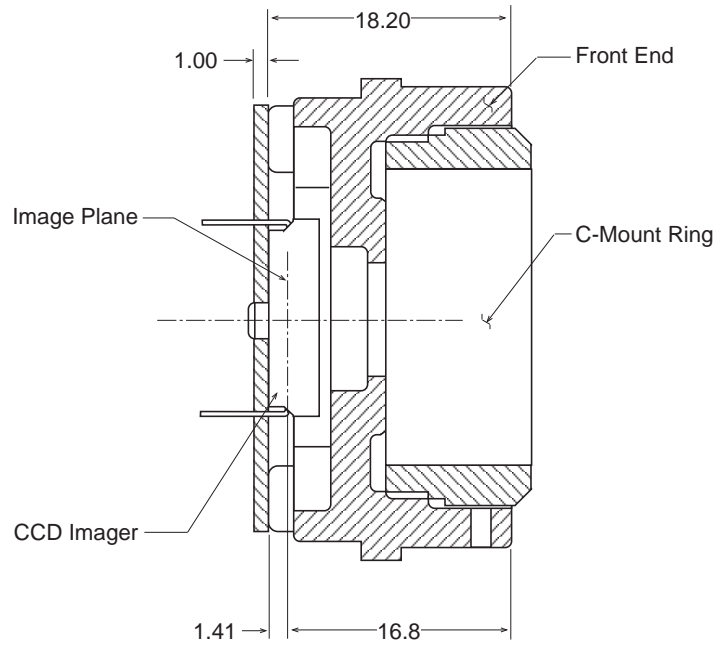
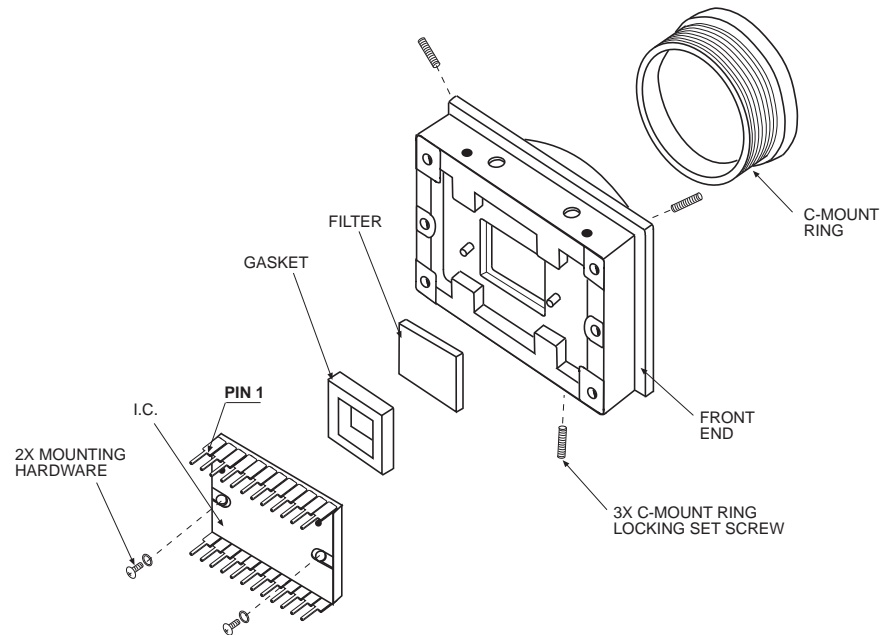

FIGURE 13.

Front End Assembly



5.2 Spectral Response

FIGURE 14.

Spectral Response

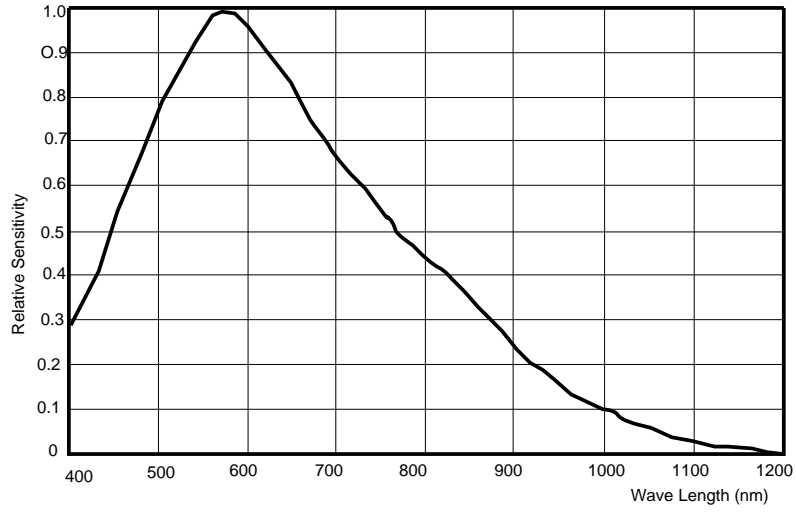



Industrial Products Division

PULNiX America Inc.
1330 Orleans Drive
Sunnyvale, CA 94089

Tel: 408-747-0300
Tel: 800-445-5444
Fax: 408-747-0660

Email: imaging@pulnix.com
www.pulnix.com