



**TM-7CN / TM-6CN
TM-7EX / TM-6EX
TM-72EX/TM-62EX
Miniature CCD Cameras**

Operations Manual

PLEASE NOTE:

The specifications and instructions in this manual apply to the TM-72EX/TM-62EX, with the following exceptions.

Imager size: 2/3" interline transfer CCD

Pixels:

TM-72EX (EIA): 768 (H) x 493 (V)

TM-62EX (CCIR): 758 (H) x 581 (V)

Cell size:

TM-72EX (EIA): 11 μ m x 13 μ m

TM-62EX (CCIR): 11 μ m x 11 μ m

TV resolution:

TM-72EX (EIA): 570 (H) x 485 (V) lines

TM-62EX (CCIR): 560 (H) x 575 (V) lines

TABLE OF CONTENTS

		Page
1.	Features and Applications	2
2.	Specifications	3
3.	Physical Dimensions	4
4.	Camera System Accessories	4
4.1	12-Pin Connector	4
4.2	Shutter Control Unit	5
4.3	Power Cables	5
4.4	Lenses	5
4.5	Power Supplies	5
5.	Setup and Operation	5
5.1	Getting Started	5
5.2	Power Supply and Power Cable Setup	5
5.3	Attaching the Video Output	6
5.4	Lenses	6
5.5	Shutter Control Setup	6
6.	Shutter Operation	7
6.1	BCD Shutter Control	7
6.2	Substrate Drain Shutter Mechanism	7
6.3	Sync Output and Clock Output	7
7.	CCD Characteristics and Operation	8
7.1	Theory of Operation	8
7.2	Mechanism of CCD Charge Transfer	8
7.3	Spectral Response	9
7.4	Field Mode and Frame Mode	9
8.	Timing Charts	10
9.	Adjustment Procedure	11
9.1	Sync Gen Board	11
9.2	Processor Board	11
9.3	Imager Board	12
10.	External Sync Version For TM-7EX/TM-6EX Only	12
10.1	External Sync Specification	12
10.2	Pin Configurations	12
10.3	Asynchronous Reset	12
10.4	Phase Adjustment	13
11.	Connector Board	13
11.1	Impedance Selection	13
11.2	Jumper Setting	13

SECTION 1 FEATURES AND APPLICATIONS

HIGH RESOLUTION, INTERLINE TRANSFER CCD

The TM-7/TM-6 series are state-of-the-art CCD cameras which use a 1/2 inch high resolution imager. These units offer outstanding compactness, high performance, long life, high stability as well as a number of technical innovations such as variable electronic shutter and asynchronous reset. They are designed to be simple yet high quality cameras for versatile applications such as machine vision and image processing, robotics, medical, and surveillance applications. The uniqueness of the TM-7 series is the size and resolution which is essential for the latest artificial intelligence. For applications requiring external sync, the TM-7EX is used.

VARIABLE ELECTRONIC SHUTTER AND RANDOM CCD INTEGRATION

The TM-7 / TM-6 series cameras have a substrate drain-type shutter mechanism which provides a superb picture at various speeds without smearing. The "CN" and "EX" model cameras have the capability to externally vary the electronic shutter rate via a manually controlled BCD switch from 1/60 to 1/10,000 sec. in discrete steps.

MINIATURIZED AND LIGHTWEIGHT

All PULNiX cameras are built with the same design principles: solid state technology; miniaturization (including lenses, housings, and cables); specialization (such as remote imager and image intensified camera versions). The use of a CCD image sensor in the video camera module and the development of special mini C-mount lenses makes it possible to produce a very compact, lightweight, and robust series of cameras. The TM-7 series is the extension of this principle and makes the entire camera just like a remoted head.

LONG LIFE: A THREE YEAR WARRANTY

The CCD solid state image sensor allows the camera to maintain a superior performance level indefinitely while requiring virtually no maintenance. PULNiX backs all of the TM series cameras with a three year warranty.

WARNING: Unscrewing the camera cover or opening the camera in any way will void this warranty.

HIGH SENSITIVITY

The TM-7 series is one of the most low light sensitive 1/2 " CCD cameras available today. This is especially important when using the faster shutter speeds. The CCD detects images into the near infrared. It requires only 1.0 lux of minimum illumination and 0.5 lux minimum illumination at maximum gain. In general, such a low light camera allows use of a higher lens F-value and provides greater depth of field and sharper images.

PRECISE IMAGE GEOMETRY

On the CCD image sensor, the photosensor elements form exact rows both horizontally and vertically so that a very precise image geometry may be obtained.

LOW LAG/HIGH RESISTANCE TO IMAGE BURNING

Compared to the lag of conventional cameras which use a pickup tube, the lag of a CCD camera is considerably reduced so that a clear picture may be obtained when shooting a rapid moving object, or when shooting in a low illumination environment. Since the CCD is highly resistant to image burning, the camera may be exposed to bright objects for a long period of time. It must be noted that a "smear" phenomenon may occur when shooting a very bright object. An infrared cutoff filter is recommended to obtain a clear picture.

HIGH RESISTANCE TO MAGNETIC FIELD AND VIBRATION/MECHANICAL SHOCK

Due to its ruggedized design, the CCD imager can withstand strong vibration and shock, and little or no noise will appear in the picture. Since the TM-7 series camera is not influenced by a magnetic field, it will produce stable images even when placed next to objects such as electric furnaces, welding machines, or NMR scanners.

QUICK START-UP AND LOW POWER CONSUMPTION

No more than 2 seconds are needed for the TM-7 series to warm up, and shooting may begin within a second after turning on the camera. The power consumption is only 3.0W. This makes the cameras excellent for use with battery operated systems.

GENLOCK CIRCUIT

A genlock circuit is not built into the TM-7 series to accept external sync. The design principle of this type of camera is intended for numerous usages in simple but demanding applications which require compact, high resolution and high quality, but most importantly, low cost cameras. External sync is built into the TM-7EX series for applications where external sync is required.

AGC SELECTION, MANUAL GAIN CONTROL AND GAMMA ADJUSTMENT

The AGC (automatic gain control) may be externally switched from automatic to fixed gain on the TM-7CN back plate. The manual gain is externally adjustable. Gamma may also be externally set either to 1 or 0.45. These adjustments are particularly important in vision system applications.

SECTION 2 SPECIFICATIONS

Imager:		1/2 inch interline transfer CCD	
Pixels		768 (H) x 494 (V) - TM-7 series	
		752 (H) x 582 (V) - TM-6 series	
Cell size		8.4 (H) x 9.8 (V) microns - TM-7 series	
		8.6 (H) x 8.3 (V) microns - TM-6 series	
Sensing area		6.41 (H) x 4.89 (V) mm	
Dynamic range		67dB	
		Low noise, blooming suppression	
Chip size		7.95 mm (H) x 6.45 mm (V)	
Scanning:		525 lines, 2:1 interlace - TM-7 (EIA) series	
		625 lines, 2:1 interlace - TM-6 (CCIR) series	
Clock		28.6363 MHz - TM-7 series	
		28.375 MHz - TM-6 series	
Pixel clock		14.31818 MHz - TM-7 series	
		14.1875 MHz - TM-6 series	
Horizontal frequency		15.734 KHz - TM-7 series	
		15.625 KHz - TM-6 series	
Vertical frequency		59.92 Hz - TM-7 series	
		50.0 Hz - TM-6 series	
Sync:		Int/Ext TM-7EX/TM-6EX	
TV resolution:		570(H) x 485(V) lines - TM-7	
		560(H) x 575(V) lines - TM-6	
Video output:		1.0V p-p composite video, 75Ω	
S/N ratio:		50 dB min.	
Minimum illumination:		1.0 lux (F=1.4) without IR cut filter	
AGC:		On (16dB standard, 32dB max) / Off	
Gamma:		0.45 or 1	
Lens mount:		C-mount	
Power requirement:		DC 12V, 2.5 W	
Operating temperature:		-10 °C to +50 °C	
Storage temperature:		-30 °C to +60 °C	
Operating humidity:		Within 70%	
Storage humidity:		Within 90%	
Vibration:		7G (200Hz to 2000Hz)	
Shock:	70G		
Dimensions:	TM-7CN	46mm (W) x 40mm (H) x 74mm (L)	1.81" (W) x 1.57" (H) x 2.95" (L)
	TM-7EX	46mm (W) x 40mm (H) x 79mm (L)	1.81" (W) x 1.57" (H) x 3.11" (L)

SECTION 3 PHYSICAL DIMENSIONS

TM-7CN/TM-6CN

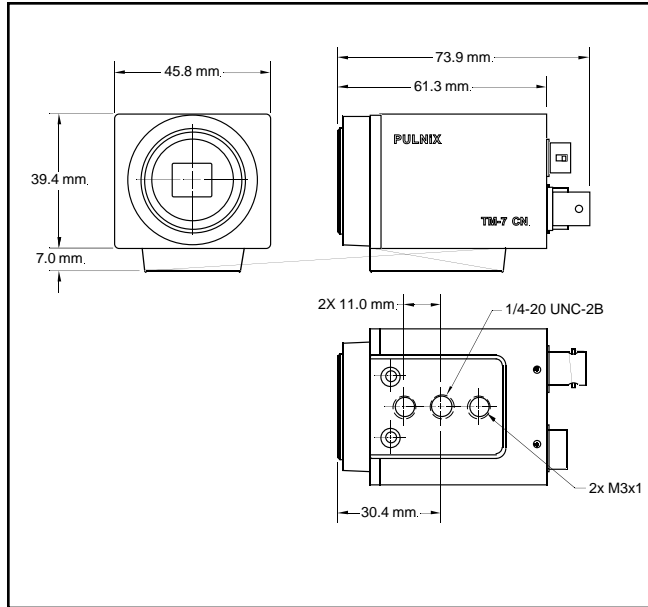

TM-7EX/6EX

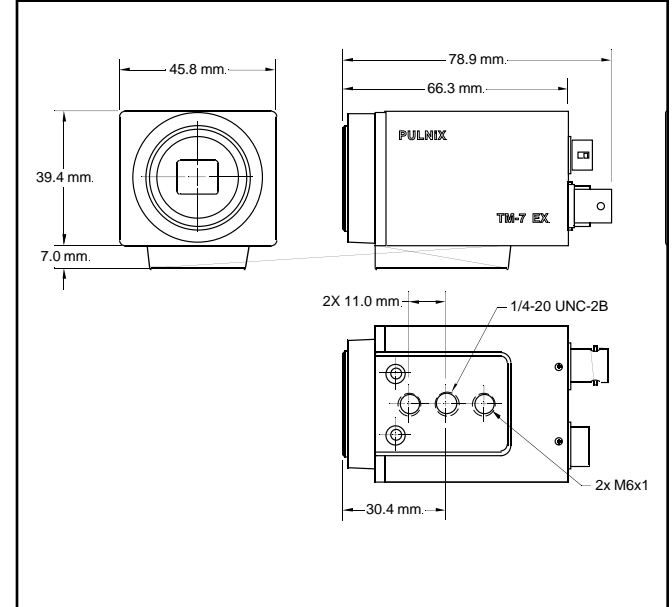

SECTION 4 CAMERA SYSTEM ACCESSORIES

4.1 12-PIN CONNECTOR

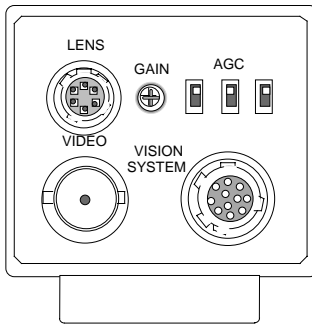

12-PIN

TM-7CN

TM-7EX

1	GND	GND
2	+12VDC	+12V DC
3	GND	GND
4	Video	VIDEO
5	N/C	N/C
6	SYNC OUT	VINIT
7	CLK OUT	VD IN
8	GND	GND
9	VINIT	HD IN
10	N/C	N/C
11	N/C	INT CONT
12	N/C	N/C

6-PIN CONNECTOR PINOUT

PIN #	FUNCTION
1	D2
2	GND
3	IRIS
4	+12V (5V OPTION)
5	D0
6	D1

4.2 **SHUTTER CONTROL UNIT (SC-745)**- consists of a manually controlled 8-position BCD switch that determines the exposure time of the sensor. It connects to the TM-7CN/TM-7EX via a cable with a PC-6P male connector that plugs into the 6-pin female connector socket on the back of the camera. The SC-745 shutter control is included with the camera.

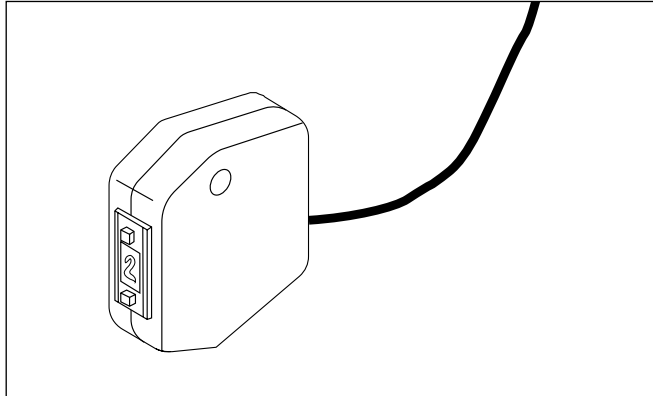

SC-745 SHUTTER CONTROL

4.3 **POWER CABLES** - all power cables use a PC-12P female connector that fits into the 12-pin male connector on the back of the TM-7CN/TM-7EX camera. Due to the connector's miniature size, PULNiX recommends purchasing the following pre-assembled cables: KC-10 10 feet, 4 conductor cable (12V, GND); 12POX Variable length, 8 conductor cable (12V, GND, Video, Clock out, Sync out, Async Vinit input I)

Note: Consult PULNiX for custom cable assemblies.

4.4 **LENSES** - PULNiX offers a wide variety of 2/3 inch format mini lenses. Auto-iris lenses must have a cable equipped with a PC-6P connector mating into the 6-pin female connector on the back of the camera.

Note: Normally, the TM-7CN and TM-7EX series cannot do variable shuttering while using an auto-iris lens because these functions share one 6-pin socket. The user has to build his own interface in order to use both an auto-iris lens and a shutter control switch. This is done by separating the +12VDC, GND and video wires (for the auto-iris lens), and the D₀, D₁, and D₂ controls (for the BCD switch).

4.5 **POWER SUPPLIES** - PULNiX recommends the following supplies:

K25-12	110V AC/12V DC,	2.1A power supply
P-15-12	220V AC/12V DC,	2.1A power supply
K50-12	110V AC/12V DC,	4.2A power supply
PD-12P	110V AC/12V DC,	0.5A power supply

SECTION 5 SETUP AND OPERATION

The operation of the TM-7 series requires a lens (mini or standard C-mount), a 12V DC regulated power supply, power and video cable assemblies and, if needed, a shutter control unit. Setup of the camera system is as follows:

5.1 **GETTING STARTED** - Please begin by checking your order to assure that you have received everything as ordered, and that nothing has been overlooked in the packing materials. It is a good idea to retain the original packing cartons for cameras and lenses should there be a need at a later date to return or exchange an item. It is also recommended that any equipment being sent to another location for field installation be bench tested to assure that everything is fully operational as a system. The following steps outline the setup procedure for PULNiX cameras.

5.2 POWER SUPPLY AND POWER CABLE SETUP

The TM-7CN/6CN and TM-7EX/6EX cameras use a 12-pin connector for power input. Consult the data sheet packed with your camera. Generally Pin #1 is Ground and Pin #2 is +12V DC. The other pins may handle a number of other input and output functions; this will be discussed in subsequent sections. For users simply providing power through the 12-pin connector, the DC-12P and PD-12P power supplies are available with the 12-pin mating connector already attached to the leads from the power supply. For those using the PULNiX power cables such as the 12P-02, KC-10, etc., be certain that unused leads are not touching and that there is no possibility that leads can short because of exposed wire (s).

The power connector may now be attached to the camera. The 12-pin power connector is keyed and will only fit in one orientation. Rotate the connector while applying slight pressure until the keyways line up. You may now press the connector into place until firmly seated. The 110V AC line cord may now be placed in the mains receptacle, and the camera is now powered up.

5.3 ATTACHING THE VIDEO OUTPUT

Most users utilize the BNC connector on the "CN" and "EX" versions for video output from the camera.

Connect the output from the camera to the input of your monitor, VCR, or switching device. The input of the monitor should be balanced for 75Ω termination. Standard RG-59 type coaxial cable should carry a full video signal for up to 500 feet.

5.4 LENSES

C-mount lenses are attached to the camera by carefully engaging the threads and rotating the lens clockwise until it firmly seats on the mounting ring. Do not force the lens if it does not seat properly. Some lenses with extremely long flangebacks may exceed the mounting depth of the camera. The TM-7 series cameras use 1/2" format lenses.

5.4.1 BACK FOCUSING LENSES

To backfocus the TM-7CN, TM-7EX cameras, first attach a C-mount lens in the mount. Be certain that the lens is properly seated. Next set the lens focus to infinity (and if the lens is a manual iris, set the iris to a high f number while still retaining a well illuminated image). Try to obtain the best focus at this setting. Then loosen the two miniature hex head set screws locking the focus ring in place. Now turn the entire lens and focus ring assembly back and forth until the best image is obtained. This will set your backfocus. Once the best image is obtained, tighten the focus ring set screws.

5.4.2 AUTO-IRIS LENS SETUP

Power down the camera before attaching auto-iris lens. Mount the auto-iris lens following the instructions above. Plug the connector provided on the lens into the connector on the rear of the camera marked AUTO-IRIS or simply LENS. You may now power up the camera. Point camera at a light area and then quickly towards a darker area. If everything is working properly, the iris should adjust for the light change.

NOTE: There is a small chance that damage could occur to the auto-iris lens by plugging or unplugging the lens into the LENS connector on the camera while the camera is still powered up. It is a good idea to always remove power from the camera before connecting or disconnecting the lens.

5.5 SHUTTER CONTROL SETUP

The SC-745 Shutter Controller is used to externally vary the shutter speed of the TM-7CN/6CN and TM-7EX/6EX. This controller plugs into the 6-pin connector on the rear of the camera normally used for auto-iris lenses. Switching the controller will obtain the desired shutter speed. See the key to controller speeds on the associated data sheet for the camera being shuttered. The SC-745 must remain attached to the camera to use the shutter feature of the camera unless the camera is specially modified to shutter internally. If at a single speed it is desired to use an auto-iris lens and SC-745 at the same time, a special 6-pin connector must be made up which breaks out the SC-745 and lens connections as separate outputs. See Section 6 for pin-outs and speed menu.

SECTION 6 SHUTTER OPERATION

The TM-7/TM-6 series has a substrate drain type shutter mechanism which provides a superb picture at various speeds without smearing.

6.1 BCD SHUTTER CONTROL

By selecting D0, D1, D2 level high or low, the following shutter speeds are obtained, PULNiX provides a shutter control (SC-745), but it is also easily controlled from a computer, remote control unit, or fixed at a specific speed.

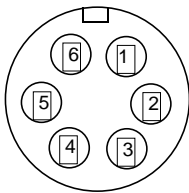

- 6 pin connector
- | | |
|-------------------|-------------------|
| 1. D ₂ | 4. +12V |
| 2. GND | 5. D ₀ |
| 3. Iris | 6. D ₁ |

Control Setting (sec)	0	1	2	3	4	5	6	7
D ₀	L	H	L	H	L	H	L	H
D ₁	L	L	H	H	L	L	H	H
D ₂	L	L	L	L	H	H	H	H

6.2 SUBSTRATE DRAIN SHUTTER MECHANISM

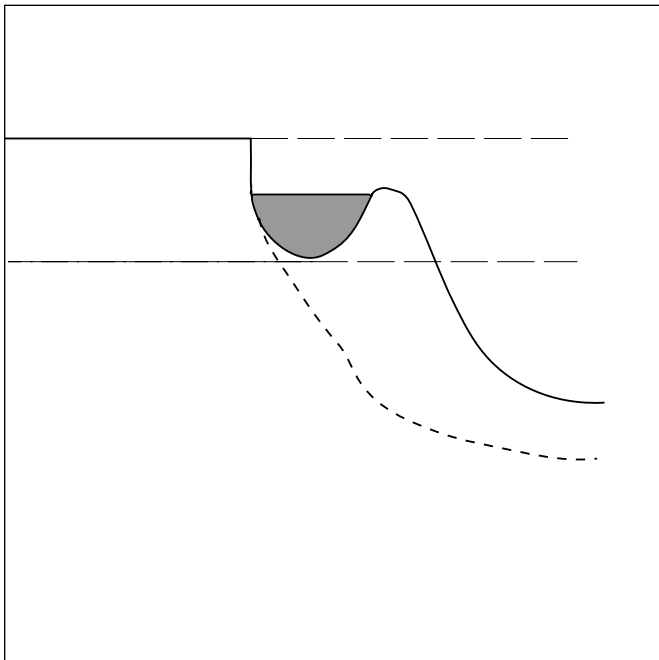

Normal operation requires the CCD chip to construct an individual potential well at each image cell. These potential wells are separated from each other by a barrier. The barrier is sequentially removed to transfer the charge from one CCD to another by the pixel clock. This is the basic principle of CCD operation for interline transfer. The substrate drain vertically moves the charges. When excess potential is applied to the substrate underneath each cell, a potential barrier is pulled down to release the charge into the drain. This can happen to all the cells simultaneously, whereas normal CCD shuttering is done with a horizontal charge shift to the drain area by interline transferring or reverse transferring of the frame transfer chip. The discharge of the TM-7/TM-6 chip is done in the horizontal blanking interval.

Note: Vertical resolution of shutter mode is one field (244). Full frame shutter is not available. If the object is motionless, the interlace signal (2 fields) can generate full vertical resolution.

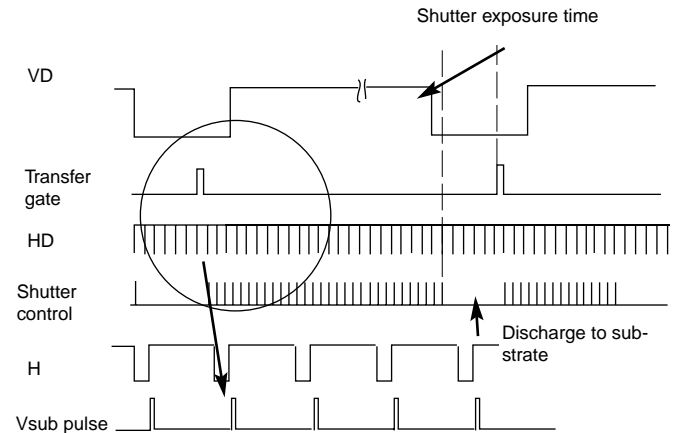

6.3 SYNC OUTPUT AND CLOCK OUTPUT

TTL level internal sync and buffered pixel clock output (14.31818MHz) are available from TM-7 series cameras.

The signal is an emitter follower output and it requires a **termination resistor at end of cable**.

The suggested value is from 75Ω to 330Ω. This is especially important for the TM-7 / TM-6 because of the cable.

SECTION 7 CCD CHARACTERISTICS AND OPERATION

7.1 THEORY OF OPERATION (Operation principle of the CCD)

A CCD (Charge Coupled Device) consists of MOS (Metal-Oxide-Semiconductor) capacitors arranged in a regular array. It basically performs three functions connected with handling charges:

1. Photoelectric conversion (photosensor). Incident light generates charges on the MOS capacitors, with the quantity of charge being proportional to the brightness.

2. Accumulation of charges. When a voltage is applied to the electrodes of the MOS capacitors, an electric potential well is formed in the silicon layer. The charge is accumulated in this well.

3. Transmission of charge. When a high voltage is applied to the electrodes, a deeper well is formed; when a low voltage is applied, a shallower well is formed. In the CCD, this property is used to transmit the charge. When a high voltage is applied to the electrodes, a deep electric potential well is formed, and charge flows in from a neighboring well. When this is repeated over and over among the regularly arranged electrodes, the charge is transferred from one MOS capacitor to another. This is the principle of CCD charge transmission.

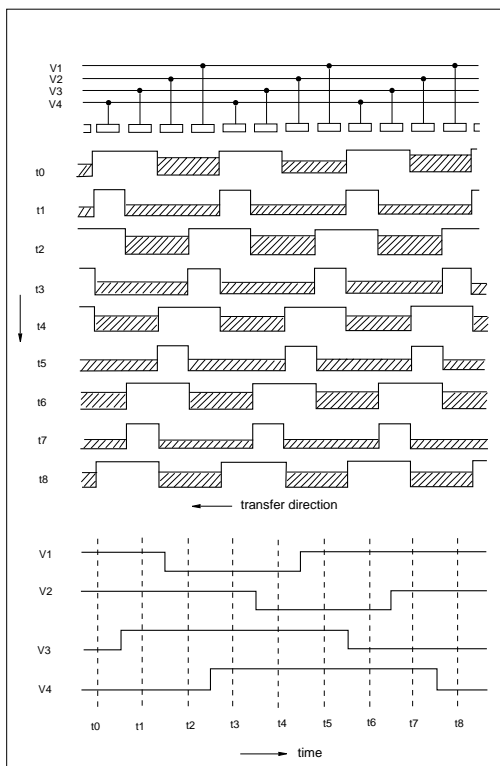

7.2 MECHANISM OF CCD CHARGE TRANSFER

1. Vertical transfer

The vertical shift register transfers charges using a four-phase drive mode. Figure 1 shows an example of the changes which can occur in potential wells in successive time intervals. At t_0 , the electrode voltages are $(V_1 = V_2) > (V_3 = V_4)$, so the potential wells are deeper toward the electrode at the higher voltages V_1 and V_2 .

Charges accumulate in these deep wells. At t_1 , the electrode voltages are $(V_1 = V_2 = V_3) > (V_4)$, so the charges accumulate in the wells toward the electrode at V_1, V_2 and V_3 . At t_2 , the electrode voltages are $(V_2 = V_3) > (V_4 = V_1)$, so the charges accumulate in the wells toward the electrode at V_2 and V_3 . Electrode voltage states at t_3 and after are shown below.

- $t_3(V_2 = V_3 = V_4) > (V_1)$
- $t_4(V_3 = V_4) > (V_1 = V_2)$
- $t_5(V_4) > (V_1 = V_2 = V_3)$
- $t_6(V_4 = V_1) > (V_2 = V_3)$
- $t_7(V_4 = V_1 = V_2) > (V_3)$
- $t_8(V_1 = V_2) > (V_3 = V_4)$ (Initial state)

These operations are repeated to execute the vertical transfer.

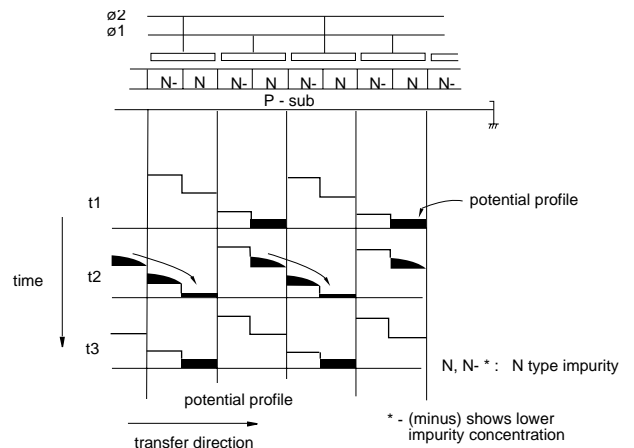

Operating Pulse Waveforms (ϕ_1, ϕ_2 or $\phi H_1, \phi H_2$)

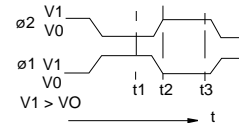

2. Horizontal transfer

The horizontal shift register transfers charges using a two-phase drive mode. Figure 2 shows an example of the changes which can occur in the potential wells in successive time intervals. At t_1 , the electrode voltages are $H_1 > H_2$, so the potential wells are deeper toward the electrode of the higher voltage H_1 . The charges accumulate in these wells. At t_2 , the electrode voltages H_1 and H_2 are inverted, the wells toward the electrode at voltage H_2 become deeper while the wells toward the electrode at voltage H_1 become shallower. So the wells at H_2 are deeper than those at H_1 , the

charge flows into the deeper wells toward the electrode at H2. At t3, the electrode voltage has not changed since t2, so the charge flows into the wells at H2 and one transfer of charge is completed. These operations are repeated to execute the horizontal transfer.

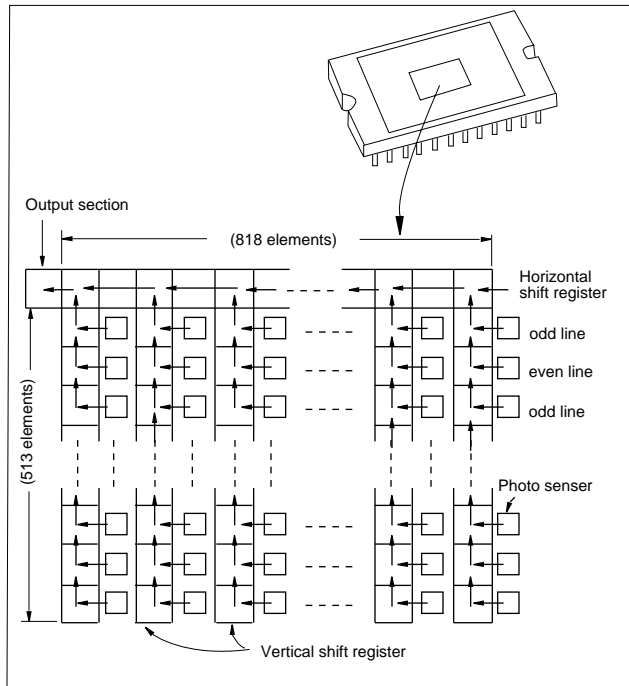

7.3 SPECTRAL RESPONSE

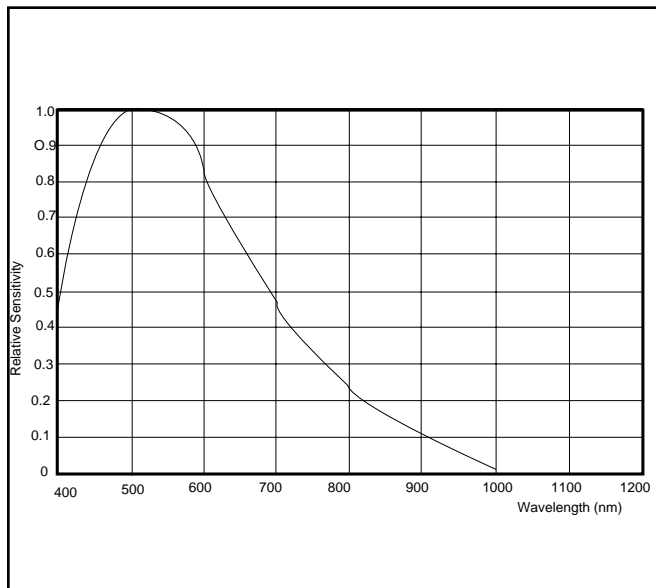

7.4 FIELD MODE AND FRAME MODE

Standard factory setting for this mode selection is FIELD MODE.

The difference of these two modes is as follows:

FRAME MODE

It scans each horizontal row as interlace scanning. During FRAME MODE, integration of each pixel is one frame period (32msec ...EIA, 40msec...CCIR). Vertical pixel resolution is good and exact location is obtained. It tends to show vertical Moire. For strobe lighting, it must use FRAME MODE in order to achieve full frame resolution.

FIELD MODE

It scans two horizontal rows together and changes the pair at each interlace scanning.

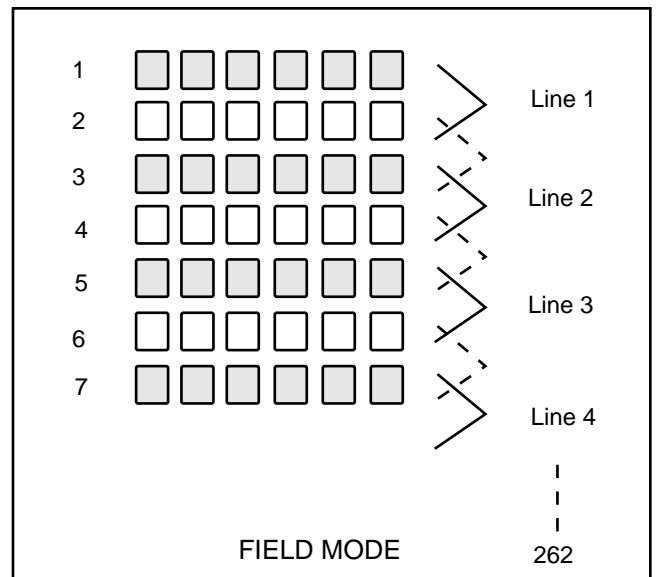

This mode has advantages when the shutter is often used as the sensitivity of the CCD is doubled for one field of integration (For shutter, integration can not exceed one field) therefore, it can obtain the same sensitivity as the FRAME MODE for half of the period. Because of alternating two row scanning, Moire is almost unnoticeable and even though the vertical resolution is not as good as in FRAME MODE it is sufficient to see the full vertical resolution of the TV format. FIELD MODE can not provide full frame resolution with strobe lighting application.

NOTE: The factory setting for the TM-7 series cameras is FIELD MODE. If FRAME MODE is required please contact PULNiX for the setting.

The mode selection is solder jumper on the process board.

SECTION 9 ADJUSTMENT PROCEDURE

9.1 Sync Gen Board

Connect Sync Gen board to test jig and check all the functions.

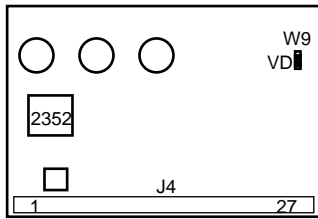

TM-7 SYNC GEN BOARD

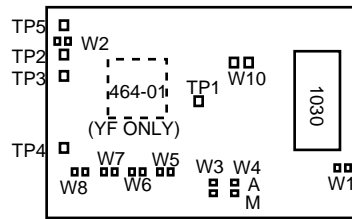

Jumper setting	standard	YF
W1 EIA/CCIR selection	Open (EIA)	Open
W2 INT Vinit	Short	Open
W3 Async mode	N/A	N/A
W4 Async/Man shutter	N/A	N/A
W5 -	Open	
W8	Open	
W9 VD in	Short	Open
W10 Vinit selection	Open	Open

9.2 Processor Board

Connect Processor board to test jig and check all the functions.

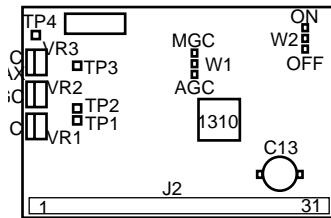

TM-7 PROCESSOR BOARD

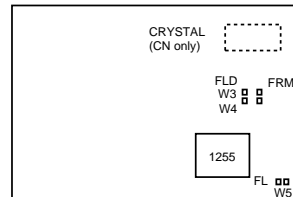

Jumper Setting	EIA	CCIR
W1 AGC/MGC	Ext. Switch	Open
W2 Gamma 1/0.45	Ext. Switch	Open
W3 Field/Frame	Ext. Switch	Open
W4 EIA/CCIR	Open	Short
W5 FL/0V	Open	Open

Voltage Setting

AGC Adjust VR1 (AGC) so that TP1 is $2.0V \pm 0.1V$

MGC Set VR2 (MGC) at mechanical center (2.5V at TP2). Then, set ext. gain pot. (rear panel) to 3.6V at TP2.

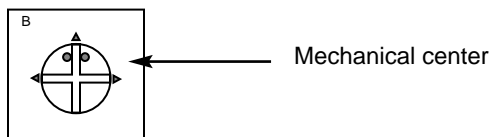

AGC MAX. Adjust VR3 (AGC MAX) to $3.0 \pm 0.1V$ at TP3.

9.3 Mother Board

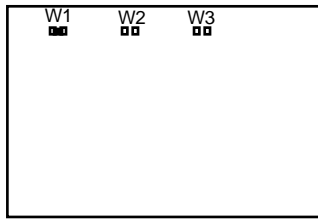

Mother Board

	Standard	YF
W1	Short	Open
W2	Open	Open
W3	Open	Open

9.3 Imager Board

Connect imager board to test jig and check all the functions.

Adjust and optimize Vsub voltage to specified value on the imager back.

E	9.0V	F	9.5V
G	10.0V	H	10.5V
J	11.0V	K	11.5V
L	12.0V	M	12.5V
N	13.0V	P	13.5V
Q	14.0V	R	14.5V
S	15.0V	T	15.5V
U	16.0V	V	16.5V
W	17.0V	X	17.5V
Y	18.0V	Z	18.5V

9.4 Factory Setting

AGC/MGC	EXT. Switch
GAMMA 1.0/0.45	EXT. Switch
FLD/FRM	EXT. Switch

SECTION 10

External Sync Version For TM-7EX/TM-6EX Only

10.1 External Sync Specification

Sync	Internal/External auto-switching
HD in	fHD = 15.734 KHz ± 5 % (EIA) fHD = 15.625 KHz ± 5 % (CCIR)
VD in	fVD = 59.94 Hz ± 5 % (EIA) fVD = 50.0 Hz ± 5 % (CCIR)
Input impedance	200Ω 75Ω (optional)

See connector board R1,R2,R3 for termination resistors.

10.2 Connector Pin Configurations

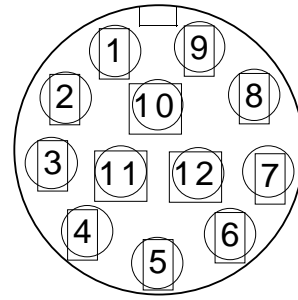

	TM-7EX/TM-6EX	S-option
1	GND	GND
2	+12V IN	+12VIN
3	GND	GND
4	VIDEO OUT	VIDEO OUT
5	N/C	N/C
6	Vinit in	HD IN
7	VD IN	VD IN
8	GND	GND
9	HD IN	VINIT IN
10	N/C	N/C
11	INT. CONT	N/C
12	N/C	N/C

10.3 Asynchronous Reset (Standard)

Asynchronous reset is available in all models. By providing reset input to Vinit pin, the TM-7 series camera can reset the scanning within 1 μsec. The reset is done for HD and VD together.

The reset pulse is TTL level and the negative going edge is the reset timing.

This feature is especially useful for strobing applications which generate full frame resolution at random reset. The captured image is always consistent with the order of odd and even fields. Asynchronous reset also eliminates "ghost image" which is caused by an overflow of charges when strong strobe lighting is applied during the middle of imager scanning.

Asynchronous reset and asynchronous shutter:
Please refer to YF instruction.

10.4 Phase Adjustment

TM-7EX GENLOCK BOARD

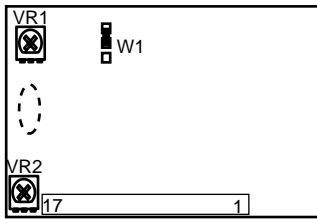

TM-7EX GENLOCK BOARD

Horizontal Lock

Apply HD to Genlock board and probe internal HD. Both External HD and Internal HD phase should line up. Observe jitter. It must be less than 20 nsec. Adjust VR2 to set the phase lock level so that TP1 DC level is $4\text{ V} \pm 1\text{ V}$.

Vertical lock

Apply VD to genlock board and probe internal VD. Adjust VR1 for vertical phase adjustment. Both External and Internal VD should line up.

Set W1 (Vertical Reset):

UP	Standard
DOWN	YF

	TM-7EX	75Ω-option	S-option
Pin 6	Vinit in Open	Open	75Ω R1 HD in
Pin 7	VD in 200Ω R2	75Ω R2	75Ω R2
Pin 9	HD in 200Ω R3	75Ω R3	Vinit(Open)

11.2 Jumper setting

	TM-7CN	TM-7EX	S-Option
W1	Short	Open	Open
W2	Short	Open	Open
W3	Open	T side	S side
W4	S side	T.C side	S side
W5	Open	Open	Short
W6	Open	Short	Short
W7	Open	Short	Open

SECTION 11 CONNECTOR BOARD

11.1 Impedance selection



TM-7 SERIES REAR BOARD

Standard input/output impedance for Pins 6, 7 and 9 of 12-pin connector is as follows:

	TM-7 CN	Option
Pin 6	Sync out TTL (OPEN)	Open
Pin 7	Clock out Emitter follower	50Ω on R2
Pin 9	Vinit in Open R3	75Ω on R3

NOTICE

The material contained in this manual consists of information that is proprietary to PULNiX America, Inc., and may only be used by the purchasers of this product. PULNiX America, Inc. makes no warranty for the use of its products and assumes no responsibility for any errors which may appear or for damages resulting from the use of the information contained herein. PULNiX America, Inc. reserves the right to make changes without notice.

WARRANTY

All our solid-state cameras have a full three year warranty. If any such product proves defective during this warranty period, Pulnix America, Inc. will repair the defective product without charge for parts and labor or will provide a replacement in exchange for the defective product. This warranty shall not apply to any damage, defect or failure caused by improper use or inadequate maintenance and use.

Revised Printing: May, 2002

In Australia
PULNiX America Inc.
Unit 16, #35 Garden Road
Clayton, Vic 3168
Tel: 3-9546-0222
Fax: 3-9562-4892

In the U.K.
PULNiX Europe Ltd.
Aviary Court, Wade Road
Basingstoke, Hants RG24 8PE
Tel: 01256-475555
Fax: 01256-466268



Industrial Products Division

PULNiX America Inc.
1330 Orleans Drive
Sunnyvale, CA 94089

Tel: 408-747-0300
Tel: 800-445-5444
Fax: 408-747-0660

In Germany
PULNiX Europe Ltd.
Steinbruch 5
D-8755 Alzenau
Tel: 06023-4666
Fax: 06023-4667

In Japan
Takenaka System Co. Ltd.
7-1, Shinomiya Narano Cho
Yamashina-ku, Kyoto, 607
Tel: 075-593-9787